

---

ABB INDUSTRIAL DRIVES

# ACS880-01 drives

## Hardware manual





# ACS880-01 drives

## Hardware manual

Table of contents



1. Safety instructions



4. Mechanical installation



6. Electrical installation –  
Global (IEC)



7. Electrical installation – North  
America (NEC)



10. Start-up



3AUA0000078093 Rev S  
EN

Original instructions  
EFFECTIVE: 2022-06-01





# Table of contents

---

## 1 Safety instructions

Contents of this chapter .....	15
Use of warnings and notes .....	15
General safety in installation, start-up and maintenance .....	16
Electrical safety in installation, start-up and maintenance .....	18
Electrical safety precautions .....	18
Additional instructions and notes .....	19
Printed circuit boards .....	19
Grounding .....	20
General safety in operation .....	21
Additional instructions for permanent magnet motor drives .....	21
Safety in installation, start-up, maintenance .....	21
Safety in operation .....	22

## 2 Introduction to the manual

Contents of this chapter .....	23
Target audience .....	23
Categorization by frame size and option code .....	23
Quick installation, commissioning and operation flowchart .....	24
Terms and abbreviations .....	25
Related documents .....	27

## 3 Operation principle and hardware description

Contents of this chapter .....	29
Product overview .....	29
Main circuit .....	30
Layout .....	31
IP21, UL Type 1 .....	31
IP55 (option +B056) .....	32
UL Type 12 (option +B056) .....	33
IP20 (UL Type Open, options +P940 and +P944) .....	33
Overview of power and control connections .....	34
Control panel .....	35
Control panel mounting platform cover .....	35
Control panel door mounting kits .....	35
Type designation label .....	36
Type designation key .....	37
Basic code .....	37

---

Option codes ..... 37

**4 Mechanical installation**

Contents of this chapter ..... 41

Safety ..... 41

Mounting positions ..... 42

Required free space ..... 42

Examining the installation site ..... 42

Required tools ..... 43

Moving the drive ..... 43

Unpacking and examining the delivery ..... 43

    Examining the delivery ..... 43

    Package of frames R1 to R5 ..... 44

        Frame R5 cable box (IP21, UL Type 1) ..... 46

    Package of frames R6 and R7 ..... 47

        Frame R6 cable box (IP21, UL Type 1) ..... 49

        Frame R7 cable box (IP21, UL Type 1) ..... 50

    Package of frames R8 and R9 ..... 51

        Frame R8 cable box (IP21, UL Type 1) ..... 53

        Frame R9 cable box (IP21, UL Type 1) ..... 54

Installing the drive ..... 54

    Vibration dampers (option +C131) ..... 54

    Flange mounting (option +C135) ..... 55

    UK gland plate (option +H358) ..... 55

    Cabinet installation (options +P940 and +P944) ..... 55

    Frames R1 to R4 (IP21, UL Type 1) ..... 56

    Frames R5 to R9 (IP21, UL Type 1) ..... 57

    Frames R1 to R9 (IP55, UL Type 12) ..... 59

**5 Guidelines for planning the electrical installation**

Contents of this chapter ..... 61

Limitation of liability ..... 61

Selecting the main supply disconnecting device ..... 61

    European Union and United Kingdom ..... 62

    North America ..... 62

    Other regions ..... 62

Selecting the main contactor ..... 62

    North America ..... 62

    Other regions ..... 62

Examining the compatibility of the motor and drive ..... 63

    Protecting the motor insulation and bearings ..... 63

    Requirements tables ..... 63

        Requirements for ABB motors,  $P_n < 100$  kW (134 hp) ..... 64

        Requirements for ABB motors,  $P_n \geq 100$  kW (134 hp) ..... 65



Requirements for non-ABB motors, $P_n < 100$ kW (134 hp) .....	66
Requirements for non-ABB motors, $P_n \geq 100$ kW (134 hp) .....	67
Abbreviations .....	68
Availability of du/dt filter and common mode filter by drive type .....	68
Additional requirements for explosion-safe (EX) motors .....	68
Additional requirements for ABB motors of types other than M2_, M3_, M4_, HX_ and AM_ .....	68
Additional requirements for braking applications .....	68
Additional requirements for ABB high-output and IP23 motors ..	68
Additional requirements for non-ABB high-output and IP23 motors .....	69
Additional data for calculating the rise time and the peak line-to-line voltage .....	70
Additional note for sine filters .....	71
Selecting the power cables .....	72
General guidelines .....	72
Typical power cable sizes .....	72
Power cable types .....	72
Preferred power cable types .....	72
Alternate power cable types .....	73
Not allowed power cable types .....	74
Additional guidelines, North America .....	75
Metal conduit .....	75
Power cable shield .....	76
Grounding requirements .....	76
Additional grounding requirements – IEC .....	77
Additional grounding requirements – UL (NEC) .....	78
Selecting the control cables .....	78
Shielding .....	78
Signals in separate cables .....	78
Signals that can be run in the same cable .....	78
Relay cable .....	79
Control panel to drive cable .....	79
PC tool cable .....	79
Routing the cables .....	79
General guidelines – IEC .....	79
General guidelines – North America .....	80
Continuous motor cable shield/conduit or enclosure for equipment on the motor cable .....	81
Separate control cable ducts .....	82
Implementing short-circuit and thermal overload protection .....	82
Protecting the drive and the input power cable in short-circuits .....	82
Protecting the motor and motor cable in short-circuits .....	83
Protecting the drive against thermal overload .....	83



## 8 Table of contents

Protecting the input power cable against thermal overload .....	83
Protecting the motor cables against thermal overload .....	83
Protecting the motor against thermal overload .....	84
Protecting the motor against overload without thermal model or temperature sensors .....	84
Protecting the drive against ground faults .....	84
Residual current device compatibility .....	84
Connecting drives to a common DC system .....	85
Implementing the emergency stop function .....	85
Implementing the Safe torque off function .....	85
Implementing the functions provided by the FSO safety functions module ..	85
Implementing an ATEX-certified motor thermal protection .....	85
Implementing the power loss ride-through function .....	86
Using power factor compensation capacitors with the drive .....	87
Controlling a contactor between drive and motor .....	87
Implementing a bypass connection .....	88
Example bypass connection .....	88
Switching the motor power supply from drive to direct-on-line ..	90
Switching the motor power supply from direct-on-line to drive ..	90
Protecting the contacts of relay outputs .....	90
Implementing a motor temperature sensor connection .....	91
Connecting a motor temperature sensor to the drive through an option module .....	92
Connection of motor temperature sensor to the drive via a relay .....	93
PTC (IEC 60800-5-1) .....	93
Pt100 (IEC 90800-5-1) .....	94

## 6 Electrical installation – Global (IEC)

Contents of this chapter .....	95
Safety .....	95
Required tools .....	95
Grounding the motor cable shield at the motor end .....	95
Measuring the insulation .....	96
Measuring the insulation resistance of the drive .....	96
Measuring the insulation resistance of the input power cable .....	96
Measuring the insulation resistance of the motor and motor cable .....	96
Measuring the insulation resistance of the brake resistor circuit .....	97
Grounding system compatibility check .....	97
Corner-grounded and midpoint-grounded 525...690 V delta systems ..	98
Connecting the power cables .....	99
Connection diagram .....	99
Connection procedure for frames R1 to R3 .....	100
Connection procedure for frames R4 and R5 .....	103
Connection procedure for frames R6 to R9 .....	108

Connecting the control cables .....	115
Connection process .....	115
Connecting a PC .....	117
Panel bus (control of several units from one control panel) .....	117
Installing option modules .....	120
Fieldbus cabling .....	121
Installing FSO-xx safety functions modules .....	125
Installation procedure .....	125

## 7 Electrical installation – North America (NEC)

Contents of this chapter .....	127
Safety .....	127
Required tools .....	127
Measuring the insulation .....	127
Grounding system compatibility check .....	128
Connecting the power cables .....	128
Connection diagram .....	128
Connection procedure for frames R1 to R3 .....	130
Connection procedure for frames R4 and R5 .....	133
Connection procedure for frames R6 to R9 .....	138
Connecting the control cables .....	141
Connection procedure .....	141
Connecting a PC .....	146
Panel bus (control of several units from one control panel) .....	147
Installing option modules .....	147

## 8 Control units of the drive

Contents of this chapter .....	149
ZCU-12 layout .....	150
Default I/O diagram of the drive control unit (ZCU-1x) .....	151
Additional information on the connections .....	153
External power supply for the control unit (XPOW) .....	153
DI6 as a PTC sensor input .....	153
AI1 or AI2 as a Pt100, Pt1000, PTC or KTY84 sensor input .....	153
DILL input .....	154
The XD2D connector .....	154
Safe torque off (XSTO) .....	155
FSO safety functions module connection (X12) .....	155
Connector data .....	156
ZCU-1x ground isolation diagram .....	159

## 9 Installation checklist

Contents of this chapter .....	161
--------------------------------	-----



Checklist ..... 161

**10 Start-up**

Contents of this chapter ..... 165  
Start-up procedure ..... 165

**11 Fault tracing**

Contents of this chapter ..... 167  
LEDs ..... 167  
    Warning and fault messages ..... 167

**12 Maintenance**

Contents of this chapter ..... 169  
Maintenance intervals ..... 169  
    Description of symbols ..... 169  
    Recommended maintenance intervals after start-up ..... 170  
Cleaning the exterior of the drive ..... 171  
Cleaning the heatsink ..... 171  
Fans ..... 172  
    Replacing the main cooling fan of frames R1 to R3 ..... 173  
    Replacing the auxiliary cooling fan of IP55 frames R1 to R3 ..... 174  
    Replacing the main cooling fan of frames R4 and R5 ..... 175  
    Replacing the auxiliary cooling fan of frames R4 and R5 ..... 176  
    Replacing the main cooling fan of frames R6 to R8 ..... 177  
    Replacing the auxiliary cooling fan of frames R6 to R9 (IP21, UL Type  
    1) ..... 178  
    Replacing the second auxiliary cooling fan of frame R9 (IP55, UL Type  
    12) ..... 179  
    Replacing the auxiliary cooling fan in the IP55 (UL Type 12) cover, frames  
    R8 and R9 ..... 180  
    Replacing the main cooling fans of frame R9 ..... 182  
Replacing the drive (IP21, UL Type 1, frames R1 to R9) ..... 183  
Capacitors ..... 185  
    Reforming the capacitors ..... 185  
Control panel ..... 185  
Control unit ..... 185  
    Replacing the memory unit of ZCU-12 ..... 185  
    Replacing the ZCU-12 control unit battery ..... 186  
Replacing safety functions modules (FSO-12, option +Q973 and FSO-21,  
option +Q972) ..... 186  
Functional safety components ..... 186



**13 Technical data**

Contents of this chapter .....	189
Marine type-approved drives (option +C132) .....	189
Drives for SynRM motors .....	189
Ratings .....	190
Definitions .....	196
Deratings .....	196
Surrounding air temperature derating .....	196
Altitude derating .....	198
Deratings for special settings in the drive control program .....	198
Fuses (IEC) .....	208
aR fuses DIN 43653 stud-mount (frames R1 to R9) .....	208
aR fuses DIN 43620 blade style (frames R1 to R9) .....	212
gG fuses DIN 43620 blade style (frames R1 to R9) .....	215
Quick guide for selecting between gG and aR fuses .....	218
Calculating the short-circuit current of the installation .....	221
Calculation example .....	221
Fuses (UL) .....	223
Circuit breakers (IEC) .....	226
ABB miniature and molded case circuit breakers .....	226
Circuit breakers (UL) .....	228
ABB inverse time circuit breakers .....	228
230 V circuit breakers .....	229
480 V circuit breakers .....	229
600 V circuit breakers .....	230
Dimensions, weights and free space requirements .....	233
Package dimensions .....	235
Free space requirements .....	235
Losses, cooling data and noise .....	236
Cooling air flow and heat dissipation for flange mounting (option +C135) .....	238
Connector and entry data for the power cables .....	240
IEC .....	240
UL .....	242
Connector data for the control cables .....	243
Power cables .....	243
Electrical power network specification .....	246
Motor connection data .....	247
Efficiency .....	247
Energy efficiency data (ecodesign) .....	247
Protection classes .....	248
Ambient conditions .....	248
Colors .....	249
Materials .....	249
Drive .....	249



12 Table of contents

Package materials for small wall-mounted drives and converter modules ..... 250

Package materials for large wall-mounted drives and converter modules ..... 250

Package materials for options, accessories and spare parts ..... 250

Materials of manuals ..... 250

Disposal ..... 250

Applicable standards ..... 251

Markings ..... 252

Compliance with the EN 61800-3:204 + A1:2012 ..... 253

    Definitions ..... 253

    Category C2 ..... 253

    Category C3 ..... 254

    Category C4 ..... 255

Declarations of conformity ..... 256

UL checklist ..... 256

Approvals ..... 257

Design lifetime expectancy ..... 257

Disclaimers ..... 257

    Generic disclaimer ..... 257

    Cybersecurity disclaimer ..... 257



**14 Dimension drawings**

Contents of this chapter ..... 259

Frame R1 (IP21, UL Type 1) ..... 260

Frame R1 (IP55, UL Type 12) ..... 261

Frame R2 (IP21, UL Type 1) ..... 262

Frame R2 (IP55, UL Type 12) ..... 263

Frame R3 (IP21, UL Type 1) ..... 264

Frame R3 (IP55, UL Type 12) ..... 265

Frame R4 (IP21, UL Type 1) ..... 266

Frame R4 (IP55, UL Type 12) ..... 267

Frame R5 (IP21, UL Type 1) ..... 268

Frame R5 (IP55, UL Type 12) ..... 269

Frame R6 (IP21, UL Type 1) ..... 270

Frame R6 (IP55, UL Type 12) ..... 271

Frame R7 (IP21, UL Type 1) ..... 272

Frame R7 (IP55, UL Type 12) ..... 273

Frame R8 (IP21, UL Type 1) ..... 274

Frame R8 (IP55, UL Type 12) ..... 275

Frame R9 (IP21, UL Type 1) ..... 276

Frame R9 (IP55, UL Type 12) ..... 277



**15 Resistor braking**

Contents of this chapter .....	279
Operation principle and hardware description .....	279
Planning the braking system .....	279
Selecting the brake circuit components .....	279
Selecting a custom resistor .....	280
Selecting and routing the brake resistor cables .....	281
Minimizing electromagnetic interference .....	281
Maximum cable length .....	281
EMC compliance of the complete installation .....	281
Placing the brake resistors .....	281
Protecting the system against thermal overload .....	282
Protecting the system in fault situations .....	282
Protecting the resistor cable against short-circuits .....	284
Mechanical installation .....	284
Electrical installation .....	284
Measuring the insulation of the assembly .....	284
Connection diagram .....	284
Connection procedure .....	284
Start-up .....	284
Technical data .....	285
Ratings .....	285
Degree of protection and thermal constant of the resistor .....	288
Dimensions and weights of external resistors .....	289
JBR-03 .....	289
SACE08RE44 .....	290
SACE15RE13 and SACE15RE2 .....	291
SAFUR80F500 and SAFUR90F575 .....	291
SAFUR125F500 and SAFUR200F500 .....	292

**16 The Safe torque off function**

Contents of this chapter .....	293
Description .....	293
Compliance with the European Machinery Directive and the UK Supply of Machinery (Safety) Regulations .....	294
Wiring .....	295
Activation switch .....	295
Cable types and lengths .....	295
Grounding of protective shields .....	295
Single drive (internal power supply) .....	296
Dual-channel connection .....	296
Single-channel connection .....	297
Multiple drives .....	298
Internal power supply .....	298

14 Table of contents

- External power supply ..... 299
- Operation principle ..... 300
- Start-up including validation test ..... 301
  - Competence ..... 301
  - Validation test reports ..... 301
  - Validation test procedure ..... 301
- Use ..... 303
- Maintenance ..... 305
  - Competence ..... 305
- Fault tracing ..... 306
- Safety data ..... 307
  - Terms and abbreviations ..... 308
  - TÜV certificate ..... 309
  - Declarations of conformity ..... 310

**17 Filters**



- Contents of this chapter ..... 313
- When is a common mode filter or  $du/dt$  filter needed? ..... 313
- Common mode filters ..... 313
- $du/dt$  filters ..... 314
  - $du/dt$  filter types ..... 314
  - Description, installation and technical data of the  $du/dt$  filters ..... 314
- Sine filters ..... 315
  - Selecting a sine filter for a drive ..... 315
  - Definitions ..... 317
    - Derating ..... 317
    - Description, installation and technical data ..... 317

**Further information**

---

# 1

## Safety instructions

---

### Contents of this chapter

This chapter contains the safety instructions which you must obey when you install, start-up, operate and do maintenance work on the drive. If you ignore the safety instructions, injury, death or damage can occur.



### Use of warnings and notes

Warnings tell you about conditions which can cause injury or death, or damage to the equipment. They also tell you how to prevent the danger. Notes draw attention to a particular condition or fact, or give information on a subject.

The manual uses these warning symbols:

**WARNING!**

Electricity warning tells about hazards from electricity which can cause injury or death, or damage to the equipment.

---

**WARNING!**

General warning tells about conditions other than those caused by electricity, which can cause injury or death, or damage to the equipment.

---

**WARNING!**

Electrostatic sensitive devices warning tells you about the risk of electrostatic discharge which can cause damage to the equipment.

---

## General safety in installation, start-up and maintenance

These instructions are for all personnel who do work on the drive.



### WARNING!

Obey these instructions. If you ignore them, injury or death, or damage to the equipment can occur.

- Keep the drive in its package until you install it. After unpacking, protect the drive from dust, debris and moisture.
- Use the required personal protective equipment: safety shoes with metal toe cap, safety glasses, protective gloves and long sleeves, etc. Some parts have sharp edges.
- Lift a heavy drive with a lifting device. Use the designated lifting points. See the dimension drawings.
- Be careful when handling a tall module. The module overturns easily because it is heavy and has a high center of gravity. Whenever possible, secure the module with chains. Do not leave an unsupported module unattended especially on a sloping floor.



- Beware of hot surfaces. Some parts, such as heatsinks of power semiconductors, and brake resistors, remain hot for a while after disconnection of the electrical supply.
- Vacuum clean the area around the drive before the start-up to prevent the drive cooling fan from drawing dust inside the drive.
- Make sure that debris from drilling, cutting and grinding does not go into the drive during installation. Electrically conductive debris inside the drive can cause damage or malfunction.
- Make sure that there is sufficient cooling. See the technical data.
- Before you connect voltage to the drive, make sure that all covers are in place. Do not remove the covers when voltage is connected.

- Before you adjust the drive operation limits, make sure that the motor and all driven equipment can operate throughout the set operation limits.
- Before you activate the automatic fault reset or automatic restart functions of the drive control program, make sure that no dangerous situations can occur. These functions reset the drive automatically and continue operation after a fault or supply break. If these functions are activated, the installation must be clearly marked as defined in IEC/EN/UL 61800-5-1, subclause 6.5.3, for example, "THIS MACHINE STARTS AUTOMATICALLY".
- The maximum number of drive power-ups is five in ten minutes. Too frequent power-ups can damage the charging circuit of the DC capacitors.
- If you have connected safety circuits to the drive (for example, Safe torque off or emergency stop), validate them at start-up. See separate instructions for the safety circuits.
- Beware of hot air exiting from the air outlets.
- Do not cover the air inlet or outlet when the drive is running.

**Note:**

- If you select an external source for the start command and it is on, the drive will start immediately after fault reset unless you configure the drive for pulse start. See the firmware manual.
- If the drive is in remote control mode, you cannot stop or start the drive with the control panel.
- Only authorized persons are allowed to repair a malfunctioning drive.



## Electrical safety in installation, start-up and maintenance

### ■ Electrical safety precautions

These electrical safety precautions are for all personnel who do work on the drive, motor cable or motor.

---



#### **WARNING!**

Obey these instructions. If you ignore them, injury or death, or damage to the equipment can occur.

If you are not a qualified electrical professional, do not do installation or maintenance work.

Do these steps before you begin any installation or maintenance work.

---

1. Clearly identify the work location and equipment.
2. Disconnect all possible voltage sources. Make sure that re-connection is not possible. Lock out and tag out.
  - Open the main disconnecting device of the drive.
  - If you have a permanent magnet motor connected to the drive, disconnect the motor from the drive with a safety switch or by other means.
  - Disconnect all dangerous external voltages from the control circuits.
  - After you disconnect power from the drive, always wait 5 minutes to let the intermediate circuit capacitors discharge before you continue.
3. Protect any other energized parts in the work location against contact.
4. Take special precautions when close to bare conductors.
5. Measure that the installation is de-energized. Use a quality voltage tester.
  - Before and after measuring the installation, verify the operation of the voltage tester on a known voltage source.
  - Make sure that the voltage between the drive input power terminals (L1, L2, L3) and the grounding (PE) busbar is zero.
  - Make sure that the voltage between the drive output terminals (T1/U, T2/V, T3/W) and the grounding (PE) busbar is zero.

Important! Repeat the measurement also with the DC voltage setting of the tester. Measure between each phase and ground. There is a risk of dangerous DC voltage charging due to leakage capacitances of the motor circuit. This voltage can remain charged for a long time after the drive power-off. The measurement discharges the voltage.

- Make sure that the voltage between the drive DC terminals (UDC+ and UDC-) and the grounding (PE) terminal is zero.

**Note:** If cables are not connected to the drive DC terminals, measuring the voltage from the DC terminal screws can give incorrect results.

---



6. Install temporary grounding as required by the local regulations.
7. Ask for a permit to work from the person in control of the electrical installation work.

### ■ Additional instructions and notes

---



#### **WARNING!**

Obey these instructions. If you ignore them, injury or death, or damage to the equipment can occur.

If you are not a qualified electrical professional, do not do installation or maintenance work.

---

- Make sure that the electrical power network, motor/generator, and environmental conditions agree with the drive data.
- Do not do insulation or voltage withstand tests on the drive.
- If you have a cardiac pacemaker or other electronic medical device, keep away from the area near motor, drive, and the drive power cabling when the drive is in operation. There are electromagnetic fields present which can interfere with the function of such devices. This can cause a health hazard.

#### **Note:**

- When the drive is connected to the input power, the motor cable terminals and the DC bus are at a dangerous voltage.  
The brake circuit, including the brake chopper (option +D150) and brake resistor (if installed) are also at a dangerous voltage.  
After disconnecting the drive from the input power, these remain at a dangerous voltage until the intermediate circuit capacitors have discharged.
- External wiring can supply dangerous voltages to the relay outputs of the control units of the drive.
- The Safe torque off function does not remove the voltage from the main and auxiliary circuits. The function is not effective against deliberate sabotage or misuse.

### **Printed circuit boards**

---



#### **WARNING!**

Use a grounding wristband when you handle printed circuit boards. Do not touch the boards unnecessarily. The boards contain components sensitive to electrostatic discharge.

---



## ■ Grounding

These instructions are for all personnel who are responsible for the grounding of the drive.

---



### **WARNING!**

Obey these instructions. If you ignore them, injury or death, or equipment malfunction can occur, and electromagnetic interference can increase.

If you are not a qualified electrical professional, do not do grounding work.

---

- Always ground the drive, the motor and adjoining equipment. This is necessary for the personnel safety.
- Make sure that the conductivity of the protective earth (PE) conductors is sufficient and that other requirements are met. See the electrical planning instructions of the drive. Obey the applicable national and local regulations.
- When using shielded cables, make a 360° grounding of the cable shields at the cable entries to reduce electromagnetic emission and interference.
- In a multiple-drive installation, connect each drive separately to the protective earth (PE) busbar of the power supply.





## General safety in operation

These instructions are for all personnel that operate the drive.



### WARNING!

Obey these instructions. If you ignore them, injury or death, or damage to the equipment can occur.

- If you have a cardiac pacemaker or other electronic medical device, keep away from the area near motor, drive, and the drive power cabling when the drive is in operation. There are electromagnetic fields present which can interfere with the function of such devices. This can cause a health hazard.
- Give a stop command to the drive before you reset a fault. If you have an external source for the start command and the start is on, the drive will start immediately after the fault reset, unless you configure the drive for pulse start. See the firmware manual.
- Before you activate the automatic fault reset or automatic restart functions of the drive control program, make sure that no dangerous situations can occur. These functions reset the drive automatically and continue operation after a fault or supply break. If these functions are activated, the installation must be clearly marked as defined in IEC/EN/UL 61800-5-1, subclause 6.5.3, for example, "THIS MACHINE STARTS AUTOMATICALLY".

### Note:

- The maximum number of drive power-ups is five in ten minutes. Too frequent power-ups can damage the charging circuit of the DC capacitors. If you need to start or stop the drive, use the control panel keys or commands through the I/O terminals of the drive.
- If the drive is in remote control mode, you cannot stop or start the drive with the control panel.

## Additional instructions for permanent magnet motor drives

### ■ Safety in installation, start-up, maintenance

These are additional warnings concerning permanent magnet motor drives. The other safety instructions in this chapter are also valid.



### WARNING!

Obey these instructions. If you ignore them, injury or death, or damage to the equipment can occur.

If you are not a qualified electrical professional, do not do installation or maintenance work.

## 22 Safety instructions

- Do not do work on the drive when a rotating permanent magnet motor is connected to it. A rotating permanent magnet motor energizes the drive including its input and output power terminals.

Before installation, start-up and maintenance work on the drive:

- Stop the drive.
- Disconnect the motor from the drive with a safety switch or by other means.
- If you cannot disconnect the motor, make sure that the motor cannot rotate during work. Make sure that no other system, like hydraulic crawling drives, can rotate the motor directly or through any mechanical connection like felt, nip, rope, etc.
- Do the steps in section [Electrical safety precautions](#) (page 18).
- Install temporary grounding to the drive output terminals (T1/U, T2/V, T3/W). Connect the output terminals together as well as to the PE.

During the start-up:

- Make sure that the motor cannot run overspeed, for example, driven by the load. Motor overspeed causes overvoltage that can damage or destroy the capacitors in the intermediate circuit of the drive.



### ■ Safety in operation

---



#### **WARNING!**

Make sure that the motor cannot run overspeed, for example, driven by the load. Motor overspeed causes overvoltage that can damage or destroy the capacitors in the intermediate circuit of the drive.

---

2

# Introduction to the manual

---

## Contents of this chapter

This chapter describes the intended audience and contents of the manual. It contains a flowchart of steps in examining the delivery, installing and commissioning the drive. The flowchart refers to chapters/sections in this manual and other manuals.

## Target audience

This manual is intended for people who plan the installation, install, commission and do maintenance work on the drive, or create instructions for the end user of the drive concerning the installation and maintenance of the drive.

Read the manual before you work on the drive. You are expected to know the fundamentals of electricity, wiring, electrical components and electrical schematic symbols.

## Categorization by frame size and option code

The frame size identifies information which concerns only a certain frame size of the drive. The frame size is shown on the type designation label. All frame sizes are listed in the technical data.

The option code (A123) identifies information which concerns only a certain optional selection. The options included in the drive are listed on the type designation label.

---

## Quick installation, commissioning and operation flowchart

Task	See
Identify the frame of your drive: R1...R9.	Type designation key (page 37)
↓	
Plan the electrical installation and acquire the accessories needed (cables, fuses, etc.). Check the ratings, required cooling air flow, input power connection, compatibility of the motor, motor connection, and other technical data.	Guidelines for planning the electrical installation (page 61) Technical data (page 189)
↓	
Check the installation site.	Ambient conditions (page 248)
↓	
Unpack and examine the drive (only intact units may be started up). Make sure that all necessary optional modules and equipment are present and correct. Install the drive mechanically.	Mechanical installation (page 41) If the drive has been non-operational for more than one year, the converter DC link capacitors need to be reformed, Capacitors (page 185)
↓	
Route the cables.	Routing the cables (page 79)
↓	
If the drive is about to be connected to an IT (ungrounded), corner-grounded delta, midpoint-grounded delta or TT system, check if you need to disconnect the EMC filter and ground-to-phase varistor.	ACS880 frames R1 to R11 EMC filter and ground-to-phase varistor disconnecting instructions ( <a href="#">3AJUA0000125152 [English]</a> )
↓	
Connect the power cables. Connect the control cables.	Electrical installation – Global (IEC) (page 95) or Electrical installation – North America (NEC) (page 127)
↓	
Check the installation.	Installation checklist (page 161)
↓	
Start the drive up.	Start-up (page 165)
↓	

**Task**

Operate the drive: start, stop, speed control etc.

**See**

Quick start-up guide, firmware manual

## Terms and abbreviations

Term	Description
DC link	DC circuit between rectifier and inverter
DC link capacitors	Energy storage which stabilizes the intermediate circuit DC voltage
DPMP-01	Mounting platform for control panel (flush mounting)
DPMP-02, DPMP-03	Mounting platform for control panel (surface mounting)
Drive	Frequency converter for controlling AC motors
EFB	Embedded fieldbus
EMC	Electromagnetic compatibility
EMI	Electromagnetic interference
EMT	Electrical metallic tubing, type of cable conduit
FAIO-01	Analog I/O extension module
FCAN	Optional CANopen® adapter module
FCNA-01	Optional ControlNet™ adapter module
FEN-01	Optional TTL incremental encoder interface module
FEN-11	Optional TTL absolute encoder interface module
FEN-21	Optional resolver interface module
FEN-31	Optional HTL incremental encoder interface module
FENA-21	Optional Ethernet adapter module for EtherNet/IP™, Modbus TCP and PROFINET IO protocols, 2-port
FEPL-02	Optional Ethernet POWERLINK adapter module
FIO-01	Optional digital I/O extension module
FIO-11	Optional analog I/O extension module
FMBT-21	Optional Ethernet adapter module for Modbus TCP protocol
FPBA-01	Optional PROFIBUS DP® adapter module
FPNO-21	Optional PROFINET IO adapter module
FPTC-01	Optional thermistor protection module
FPTC-02	Optional ATEX-certified thermistor protection module for potentially explosive atmospheres
Frame, frame size	Physical size of the drive or power module
FSE-31	Optional pulse encoder interface module for safety encoder
FSO-21	Safety functions module which supports the FSE-31 module and the use of safety encoders
FSO-12	Safety functions module which does not support the use of encoders
FSPS-21	Optional functional safety module
IGBT	Insulated gate bipolar transistor

## 26 Introduction to the manual

<b>Term</b>	<b>Description</b>
Inverter	Converts direct current and voltage to alternating current and voltage.
Parameter	In the drive control program, user-adjustable operation instruction to the drive, or signal measured or calculated by the drive. In some (for example fieldbus) contexts, a value that can be accessed as an object. For example, variable, constant, or signal.
PLC	Programmable logic controller
STO	Safe torque off (IEC/EN 61800-5-2)
ZCON	Type of control board
ZCU	Type of control unit
ZGAB	Brake chopper adapter board
ZGAD	Gate driver adapter board
ZINT	Main circuit board
ZMU	Type of memory unit, attached to the control unit

## Related documents

You can find manuals and other product documents in PDF format on the Internet at [www.abb.com/drives/documents](http://www.abb.com/drives/documents).

The code and link below open an online listing of the manuals applicable to this product.



[ACS880-01 manuals](#)





# 3

## Operation principle and hardware description

---

### Contents of this chapter

This chapter briefly describes the operation principle and construction of the drive.

### Product overview

The ACS880-01 is a drive for controlling asynchronous AC induction motors, permanent magnet synchronous motors, AC induction servomotors and ABB synchronous reluctance motors (SynRM motors).

The main cooling air fan of the drive is speed controlled and the auxiliary cooling fan on/off controlled.

---

■ **Main circuit**

The main circuit of the drive is shown below.

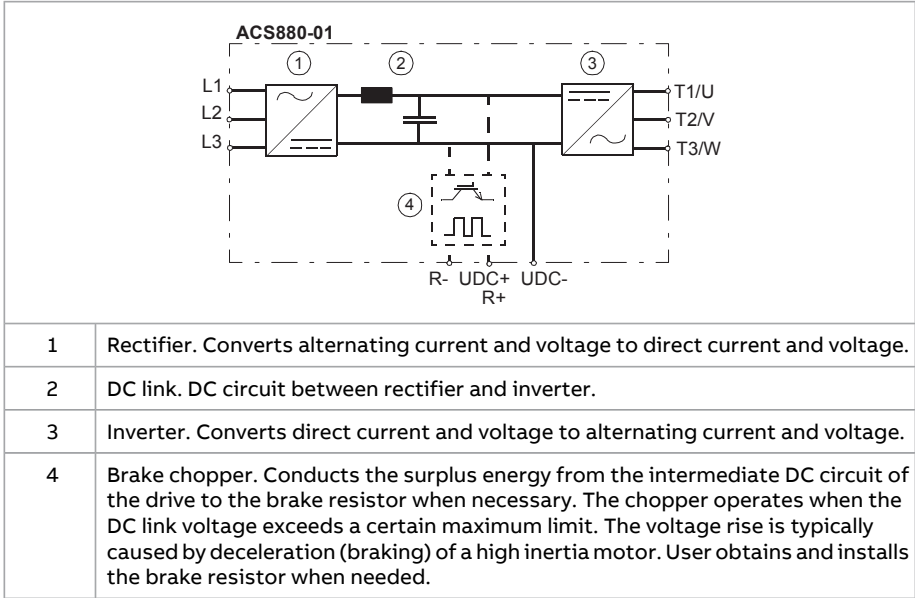

■ **Layout**

**IP21, UL Type 1**

The components of the drive are shown below (view of frame R5).



### IP55 (option +B056)

The components of the IP55 drive (option +B056) are shown below (view of frame R4).



### UL Type 12 (option +B056)

The components of the UL Type 12 drive (option +B056) are shown below (view of frame R6).

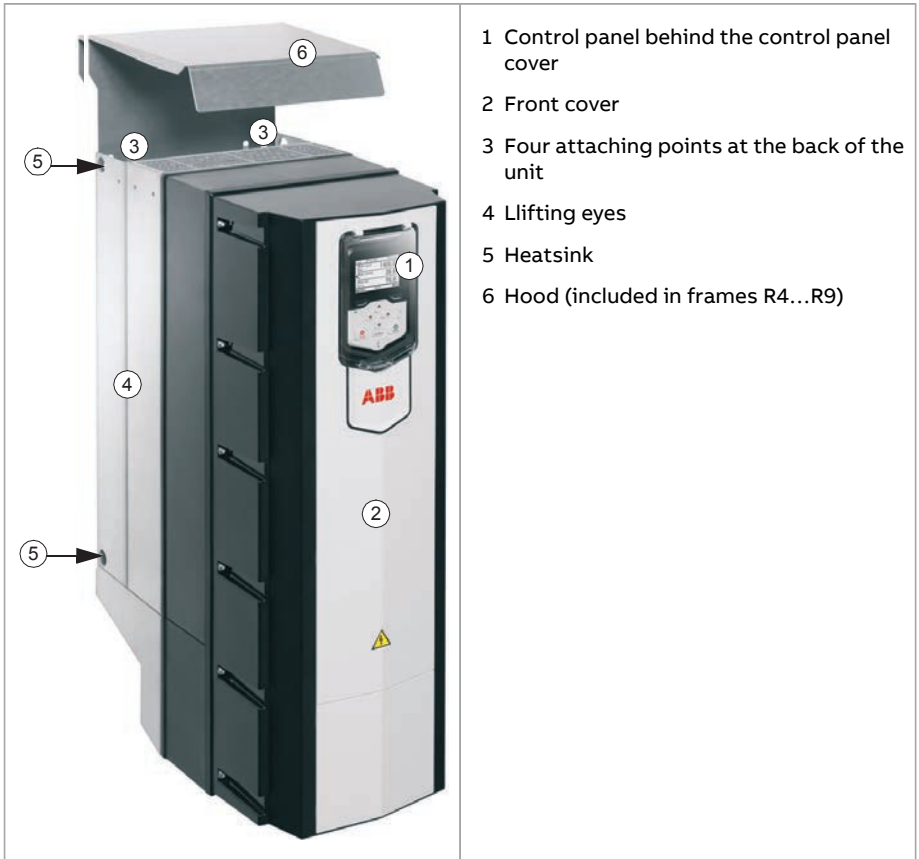

### IP20 (UL Type Open, options +P940 and +P944)

See [ACS880...+P940 and +P944 drive modules supplement \(3AUA0000145446 \[English\]\)](#).

■ Overview of power and control connections

This diagram shows the power connections and control interfaces of the drive.

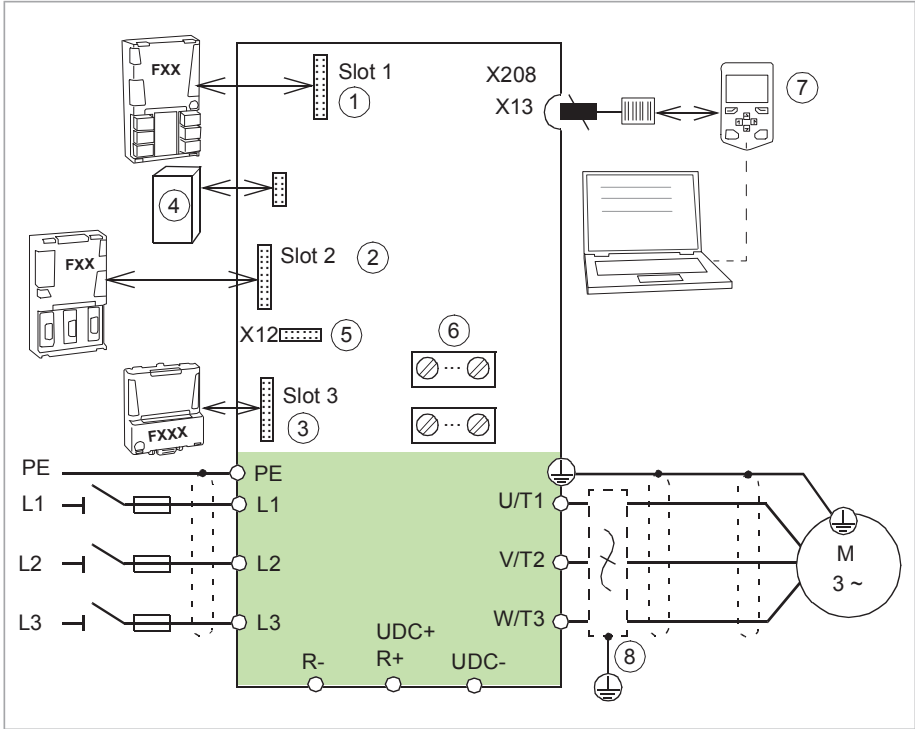

1, 2, 3	Analog and digital I/O extension modules, feedback interface modules and fieldbus communication modules can be inserted into slots 1, 2 and 3. See section Type designation key (page 37).
4	Memory unit. See section Control unit (page 185).
5	Connector for safety functions modules. See section Installing FSO-xx safety functions modules (page 125).
6	I/O connections. See chapter Control units of the drive (page 149).
7	Control panel. See section Control panel (page 35).
8	du/dt, common mode or sine filter (optional). See chapter Filters (page 313).

## ■ Control panel

The control panel can be removed by pulling it forward from the top edge and reinstalled in reverse order. For the use of the control panel, see the firmware manual or [ACS-AP-I, -S, -W and ACH-AP-H, -W Assistant control panels user's manual \(3AUA0000085685 \[English\]\)](#).



### Control panel mounting platform cover

In deliveries without control panel (option + 0J400) the control panel mounting platform is covered. The indication LEDs on the platform are visible through the protective cover. Note: The cover is not included with options +0J400+P940 and +0J400+P944.



### Control panel door mounting kits

You can use a mounting platform to mount the control panel on the cabinet door. Mounting platforms for control panels are available as options from ABB. For more information, see

## 36 Operation principle and hardware description

Manual	Code (English)
DPMP-01 mounting platform for control panels installation guide	<a href="#">3AUA0000100140</a>
DPMP-02/03 mounting platform for control panels installation guide	<a href="#">3AUA0000136205</a>
DPMP-04 and DPMP-05 mounting platform for control panels installation guide	<a href="#">3AXD50000308484</a>
DPMP-06 / 07 mounting platform for control panels installation guide	<a href="#">3AXD50000289561</a>

## Type designation label

**ABB** ACS880-01-049A-7 ①

Origin Finland  
Made in Finland  
ABB Oy  
Hiomotie 13  
00380 Helsinki  
Finland ②

FRAME  
R5 ③

Air cooling ④

IP21 ⑤ Icc 65 kA ⑦  
UL type 1  
UL/CSA: max. 600 VAC  
IE2 (90/100) 1,1 % ⑪

Input U1 3~ 525/600/690 VAC  
I1 52/52/49 A  
f1 50/60 Hz

Output U2 3~ 0...U1  
I2 52/52/49 A  
f2 0...500 Hz  
Sn 59 kVA

⑥

⑧

⑩

⑨

MSIP-REI-Abb-022A-7  
S/N: 1213505159

1	Type designation, see section <a href="#">Type designation key</a> (page 37).
2	Manufacturing address
3	Frame size
4	Cooling method
5	Degree of protection; UL/CSA specifications
6	Ratings in the supply voltage range, see section <a href="#">Ratings</a> (page 190).
7	Short-circuit withstand strength, see section <a href="#">Electrical power network specification</a> (page 246).
8	Valid markings
9	Serial number. The first digit of the serial number refers to the manufacturing plant. The next four digits refer to the unit's manufacturing year and week, respectively. The remaining digits complete the serial number so that there are no two units with the same number.
10	Link to product information
11	Typical drive losses when it operates at 90% of the motor nominal frequency and 100% of the drive nominal output current



## Type designation key

The type designation contains information on the specifications and configuration of the drive. The first digits from left express the basic drive type. The optional selections are given thereafter, separated by plus signs. The main selections are described below. Not all selections are available for all types. For more information, refer to the ordering instructions available separately on request.

### ■ Basic code

Code	Description
ACS880	Product series
<b>Type</b>	
ACS880-01-...	When no options are selected: Wall mounted drive, IP21 (UL Type 1), ACS-AP-W assistant control panel with Bluetooth connection, no EMC filter, DC choke, ACS880 primary control program, Safe torque off function, cable entry box, brake chopper in frames R1 to R4, coated boards, printed quick installation and start-up guide.
<b>Size</b>	
xxxx	See section <a href="#">Ratings (page 190)</a> .
<b>Voltage range</b>	
2	208...240 V. This is indicated in the type designation label as typical input voltage level 3 ~ 230 V AC.
3	380...415 V. This is indicated in the type designation label as typical input voltage level 3 ~ 400 V AC.
5	380...500 V. This is indicated in the type designation label as typical input voltage levels 3 ~ 400/480/500 V AC.
7	525...690 V. This is indicated in the type designation label as typical input voltage levels 3 ~ 525/600/690 V AC.

### ■ Option codes

Code	Description
B056	IP55 (UL Type 12)
C131	Vibration dampers
C132	Marine type approval
C135	Flange mounting
C205	Marine product certification issued by DNV GL
C206	Marine product certification issued by the American Bureau of Shipping (ABS)

### 38 Operation principle and hardware description

<b>Code</b>	<b>Description</b>
C207	Marine product certification issued by Lloyd's Register (LR)
C208	Marine product certification issued by Registro Italiano Navale (RINA)
C209	Marine product certification issued by Bureau Veritas
C210	Marine product certification issued by Nippon Kaiji Kyokai (NK)
D150	Brake choppers
E200	EMC filter for 2nd environment TN (grounded) system, category C3
E201	EMC filter for 2nd environment IT (ungrounded) system, category C3
E202	EMC filter for 1st environment TN (grounded) system, category C2
E208	Common mode filter
H358	Cable conduit entry (US/UK).
OJ400	No control panel
J425	ACS-AP-I control panel
J461	ACS-DCP-11 drive connectivity panel (EU variant)
K451	FDNA-01 DeviceNet™ adapter module
K454	FPBA-01 PROFIBUS DP adapter module
K457	FCAN-01 CANopen adapter module
K458	FSCA-01 RS-485 (Modbus/RTU) adapter module
K462	FCNA-01 ControlNet™ adapter module
K469	FECA-01 EtherCat adapter module
K470	FEPL-02 EtherPOWERLINK adapter module
K475	FENA-21 Ethernet adapter module for EtherNet/IP™, Modbus TCP and PROFINET IO protocols, 2-port
K490	FEIP-21 EtherNet/IP adapter module
K491	FMBT-21 Modbus/TCP adapter module
K492	FPNO-21 PROFINET IO adapter module
L500	FIO-11 analog I/O extension module (1, 2 or 3 pcs)
L501	FIO-01 digital I/O extension module
L502	FEN-31 HTL incremental encoder interface module
L503	FDCO-01 optical DDCS communication adapter module

<b>Code</b>	<b>Description</b>
L508	FDCO-02 optical DDCS communication adapter module
L516	FEN-21 resolver interface module
L517	FEN-01 TTL incremental encoder interface module
L518	FEN-11 TTL absolute encoder interface module
L521	FSE-31 pulse encoder interface module
L525	FAIO-01 analog I/O extension module
L526	FDIO-01 digital I/O extension module
N5000	Winder control program
N5050	Crane control program
N5150	Centrifuge control program
N5200	PCP (Progressive Cavity Pump) control program
N5250	Rod pump control program
N5300	Test bench control program
N5350	Cooling tower control program
N5450	Override control program
N5500	Spinning and traverse control program
N5600	ESP (Electrical Submersible Pump) control program
N5650	Tower crane control program
N7502	Control program for synchronous reluctance motors (SynRM)
N8010	Drive application programming
P904	Extended warranty 24/30
P940	Version for cabinet mounting (Drive without front cover and cable box. Includes panel holder, cable between panel holder and control unit, I/O clamp kit in frames R1, R2 and R3, main cable clamp kit in frames R4 and R5, power cable shield grounding shelf in frames R6...R9. Cannot be selected with P944.)
P944	Version for cabinet mounting (drive module with front covers but without cable box)
Q971	ATEX-certified safe disconnection function
Q972	FSO-21 safety functions module
Q973	FSO-12 safety functions module

## 40 Operation principle and hardware description

Code	Description
Q982	PROFIsafe with FSO-xx safety functions module and FENA-21 Ethernet adapter module
Q986	PROFIsafe safety functions module, FSPS-21
R700	Documentation/manuals in English
R701	German
R702	Italian
R703	Dutch
R704	Danish
R705	Swedish
R706	Finnish
R707	French
R708	Spanish
R709	Portuguese
R711	Russian
R712	Chinese
R713	Polish
R714	Turkish

**Note:** Option codes R700...R714 denote full set of printed manuals in the selected language. The delivery can include manuals in English if the requested language is not available.

---

## 4

# Mechanical installation

---

## Contents of this chapter

This chapter tells how to examine the installation site, unpack and examine the delivery and install the drive mechanically.

## Safety

---

**WARNING!**

For frame sizes R4 to R9: Use the lifting eyes of the drive when you lift the drive. Do not tilt the drive. The drive is heavy and its center of gravity is high. An overturning drive can cause physical injury.

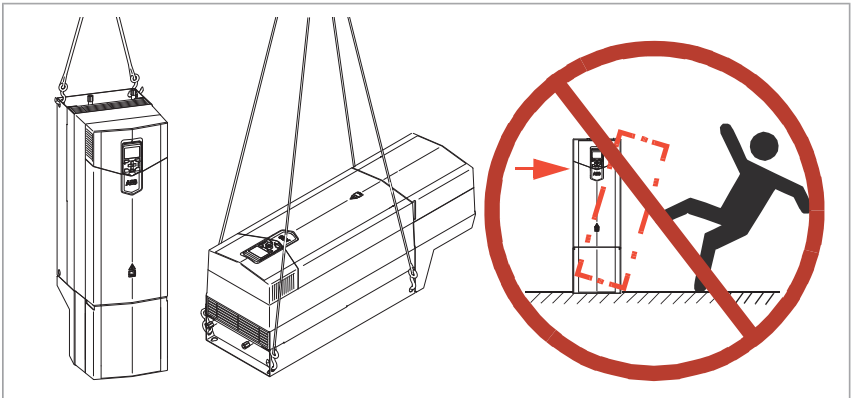

## Mounting positions

The drive must be installed in an upright position with the cooling section against a wall.

IP21 and IP55 frames R1 to R9 can be mounted side by side.

UL Type 1 frames R1 to R9 can be mounted side by side.

UL Type 12 frames R1 to R3 can be mounted side by side.

UL Type 12 frames R4 to R9 need 100 mm (4 in) between the hoods.

**Note:** Mounting the drives right next to each other side to side can make it difficult to read the serial number and rating information on the type designation label.

## Required free space

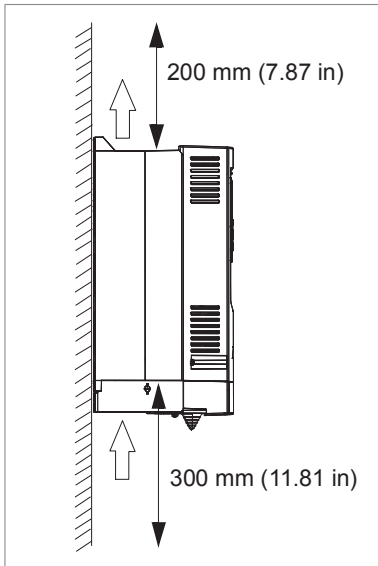

## Examining the installation site

Make sure that the installation site agrees with these requirements:

The installation site has sufficient ventilation to remove heat from the drive. See section [Losses, cooling data and noise](#) (page 236).

The operation conditions of the drive agree with the specifications in section [Ambient conditions](#) (page 248).

The wall is vertical, not flammable and strong enough to hold the weight of the drive.

The material below the installation is not flammable.

There is enough free space above the drive (200 mm [7.87 in]) and below the drive (300 mm [11.81 in]) when measured from the drive base without the cable box) for cooling air flow, service and maintenance. There is enough free space in front of the drive for operation, service and maintenance.

## Required tools

To move a heavy drive, you need crane, fork-lift or pallet truck (check load capacity!).

To lift a heavy drive, you need a hoist.

To install the drive mechanically, you need the following tools:

- drill with suitable bits
- screwdriver set (Torx, flat and/or Phillips, as appropriate)
- socket set (metric)
- tape measure, if you will not be using the provided mounting template.

## Moving the drive

Move the drive in its transport package to the installation site.

## Unpacking and examining the delivery

### ■ Examining the delivery

Examine that all the items are present and there are no signs of damage. Read the data on the type designation label of the drive module to make sure that the module is of the correct type.



■ Package of frames R1 to R5

**IP21 (UL Type 1)**

1	Drive with factory installed options. Control cable grounding shelf. Romex connectors in IP21 frames R1 to R3 in a plastic bag inside the cable box.	6...9	Cushions Mounting template on top of 6 and 7.
2	-	10	Straps
3	Printed quick guides and manuals, multilingual residual voltage warning sticker	11	Top cardboard cover
4	Cardboard tray	12	Vibration damper package (option +C131) Frame R4 and IP55 (UL Type 12) frame R5: below the cable box IP21 (UL Type 1) frame R5: inside the cable box
5	Cardboard sleeve	-	-

To unpack:  
 Cut the straps (10).  
 Remove the top cardboard cover (11) and cushions (6...9).  
 Lift the cardboard sleeve (5).  
 Lift the drive.



**IP55 (UL Type 12)**

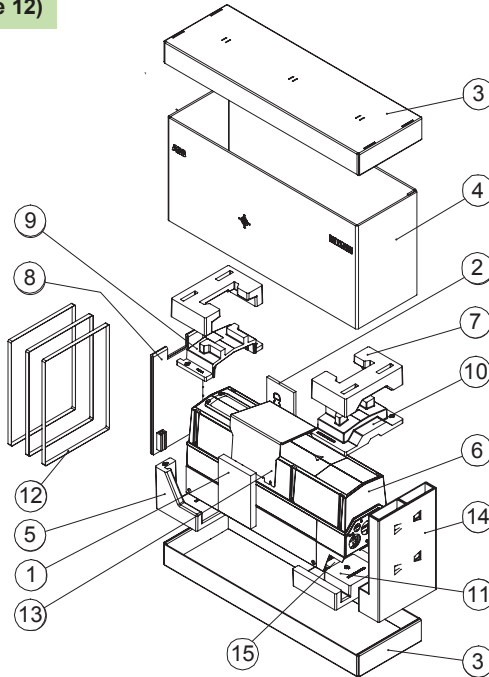

3AXD50000003341

1	Printed quick guides and manuals, multilingual residual voltage warning sticker	7...11	Cushions and cardboard support Mounting template on top of 7.
2	-	12	Straps
3	Cardboard tray + top cardboard cover	13	Hood included in frames R4 and R5. The hood is required only in UL Type 12 installations.
4	Cardboard sleeve	14	Support
5	Cushion	15	Vibration damper package (option +C131)
6	Drive with factory installed options. Control cable grounding shelf.	-	-

To unpack:  
 Cut the straps (12).  
 Remove the top cardboard cover (3) and cushions (5, 7...11).  
 Lift the cardboard sleeve (4).  
 Lift the drive.



### Frame R5 cable box (IP21, UL Type 1)

This illustration shows the contents of the cable box package. The package also includes an assembly drawing which shows how to install the cable entry box to the drive module frame.

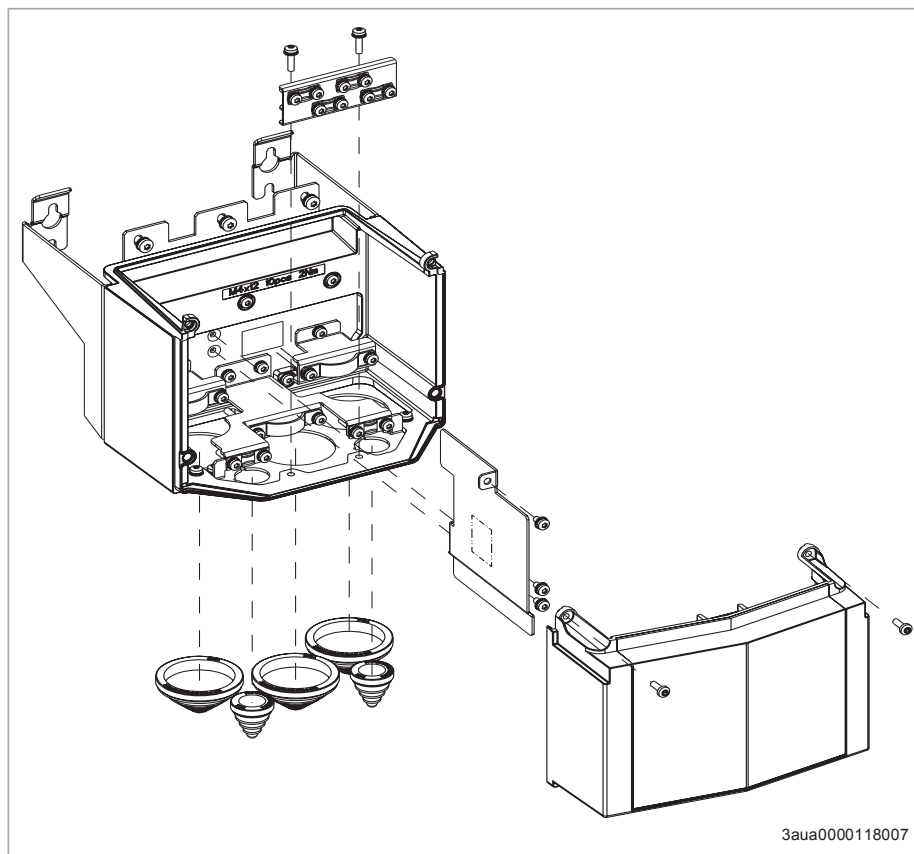

## ■ Package of frames R6 and R7

**IP21 (UL Type 1)**

3axd50000012445

1	Drive with factory installed options, mounting template	6	Cushions
2	Cable box. Power and control cable grounding shelves in a plastic bag, assembly drawing. <b>Note:</b> The cable entry box is mounted to the IP55 drive module frame at the factory	7	Straps
3	Cardboard cover	8	Printed quick guides and manuals and multilingual residual voltage warning sticker
4	Stopper	9	Vibration damper package (option +C131) <u>For frame R6:</u> inside the cable box.
5	Pallet tray	-	-

**To unpack:**  
Cut the straps (7).  
Remove the top cardboard cover (3) and cushion (6).  
Attach lifting hooks to the lifting eyes of the drive. Lift the drive with a hoist.



**IP55 (UL Type 12)**

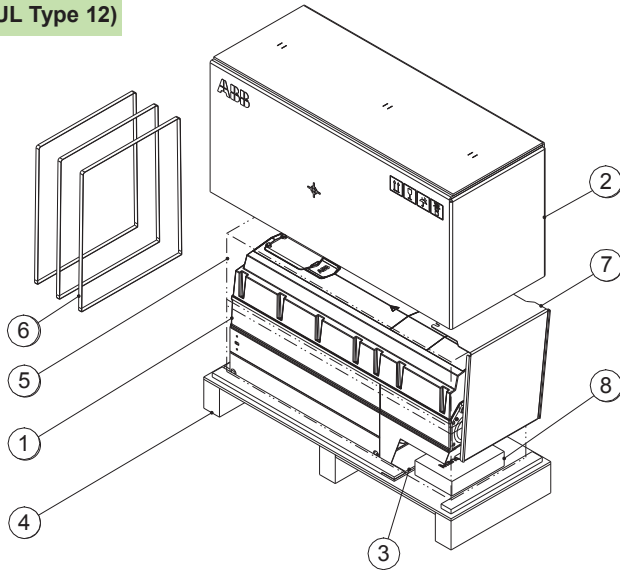

3axd5000012445

1	Drive with factory installed options, mounting template	5	Cushions
2	Cardboard cover	6	Straps
3	Stopper	7	Hood (required only in UL Type 12 installation)
4	Pallet tray	8	Printed quick guides and manuals and multilingual residual voltage warning sticker

**To unpack:**

Cut the straps (6).

Remove the top cardboard cover (2) and cushion (5).

Attach lifting hooks to the lifting eyes of the drive. Lift the drive with a hoist.



**Frame R6 cable box (IP21, UL Type 1)**

This illustration shows the contents of the cable box package. The package also includes an assembly drawing which shows how to install the cable entry box to the drive module frame.

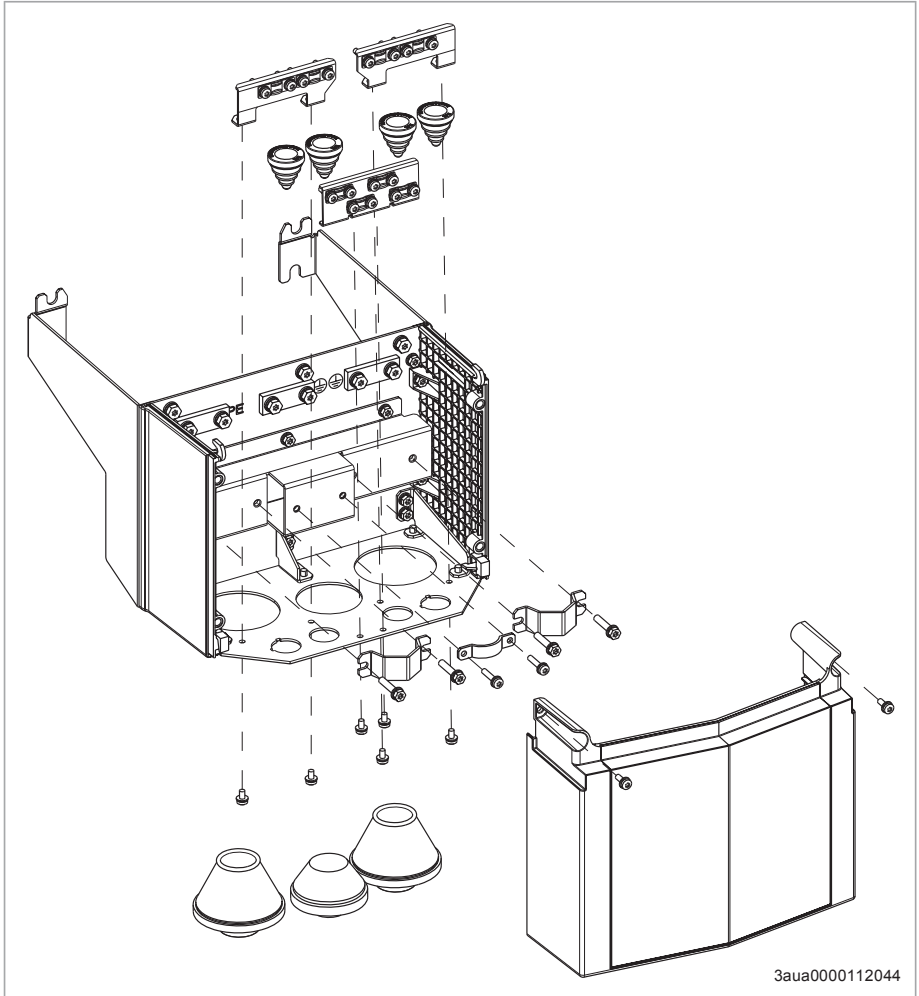

3aua0000112044

**Frame R7 cable box (IP21, UL Type 1)**

This illustration shows the contents of the cable box package. The package also includes an assembly drawing which shows how to install the cable entry box to the drive module frame.

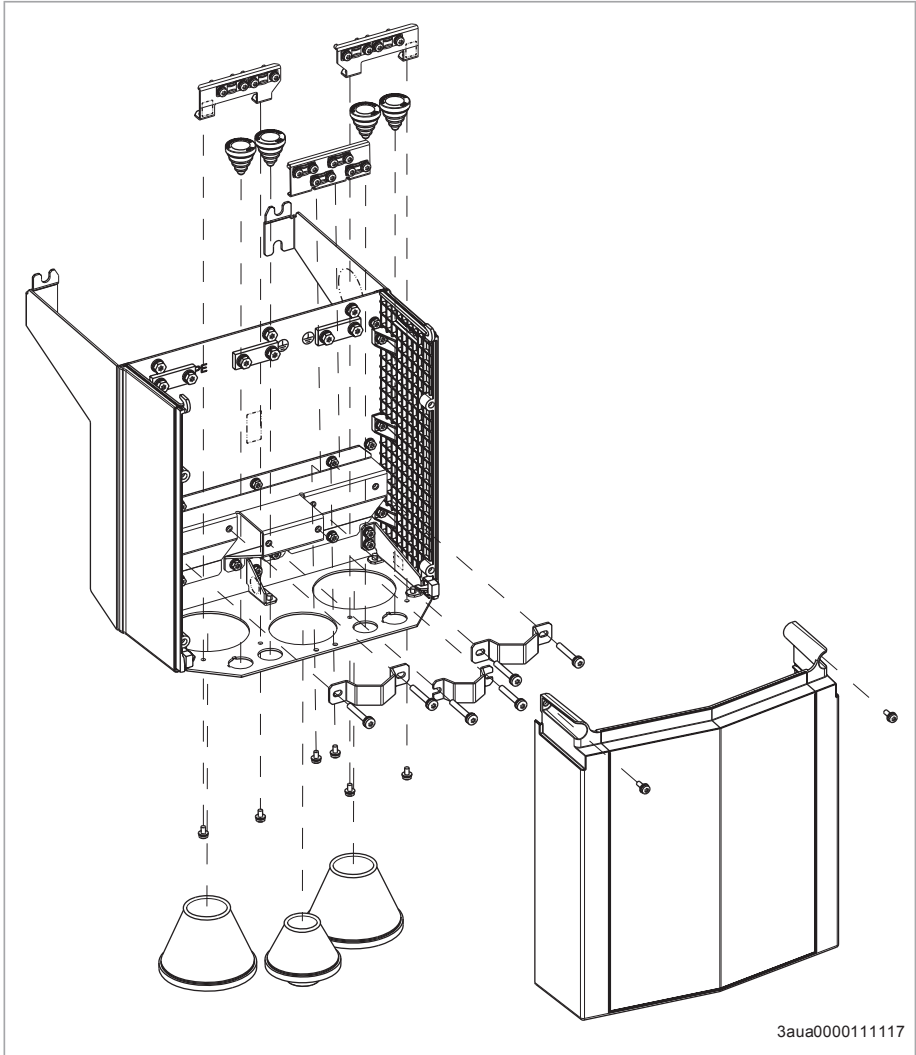

3aua0000111117

■ Package of frames R8 and R9

**IP21 (UL Type 1)**

3AXD50000106974

1	Printed quick guides and manuals and multilingual residual voltage warning sticker	7	Cardboard tray
2	VCI bag	8	Cardboard sleeve
3	Mounting template	9	Plywood support (not in R9)
4	Straps	10	Pallet tray
5	Plastic bag	11, 12	Screw
6	Packing bracket	13	Drive with factory installed options, mounting template in USA

**To unpack:**  
 Cut the straps (4).  
 Remove the tray (7) and cardboard sleeve (8).  
 Open the VCI bag (2).  
 Undo the attaching screws (a, b).  
 Lift the drive.



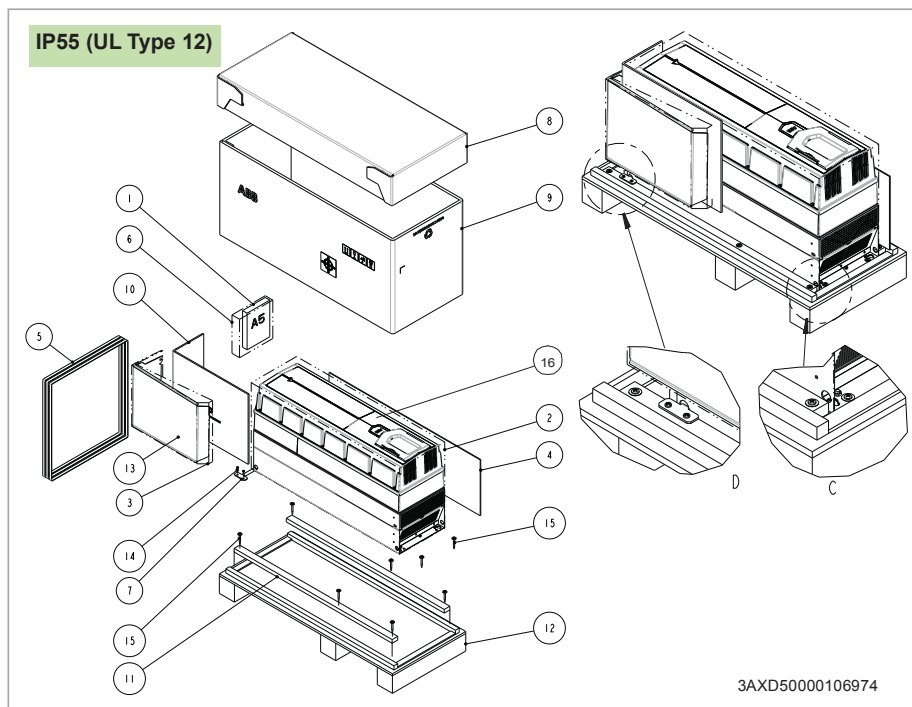

3AXD50000106974

1	Printed quick guides and manuals and multilingual residual voltage warning sticker	9	Cardboard sleeve
2	VCI bag	10	Not included
3	Bubble wrap	11	Plywood support (not in R9)
4	Mounting template	12	Pallet tray
5	Straps	13	UL Type 12 hood
6	Plastic bag	14, 15	Screw
7	Packing bracket	16	Drive with factory installed options, mounting template in USA
8	Cardboard tray	-	-

To unpack:  
 Cut the straps (5).  
 Remove the tray (8) and cardboard sleeve (9).  
 Remove the VCI bag (2).  
 Undo the attaching screws (c, d).  
 Lift the drive.





**Frame R8 cable box (IP21, UL Type 1)**

This illustration shows the contents of the cable box package. There is also an assembly drawing which shows how to install the cable entry box to the drive module frame.

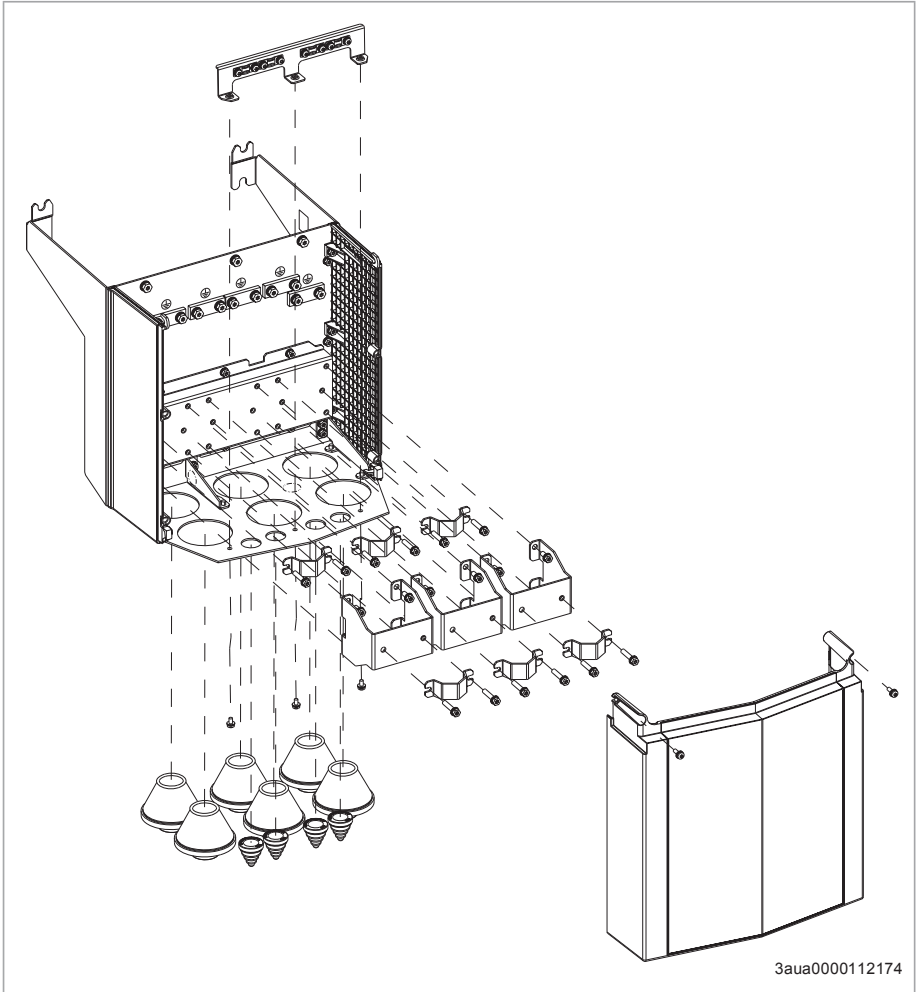

3aua0000112174

### Frame R9 cable box (IP21, UL Type 1)

This illustration shows the contents of the cable box package. The package also includes an assembly drawing which shows how to install the cable entry box to the drive module frame.

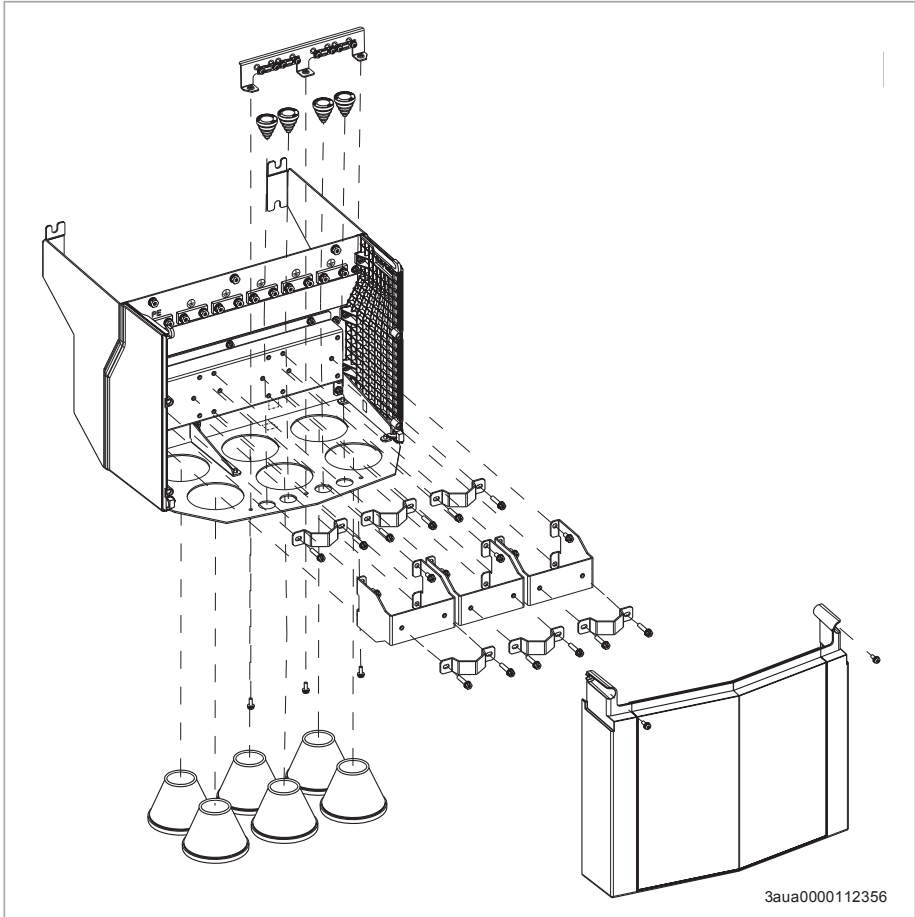

### Installing the drive

This section tells you how to install the drive on wall without vibration dampers.

#### ■ Vibration dampers (option +C131)

Marine type approval (option +C132) requires the installation of vibration dampers for frames R4 to R9 in wall installations. See [Vibration dampers for ACS880-01 drives \(frames R4 and R5, option +C131\) installation guide \(3AXD50000010497](#)

[English]) or Vibration dampers for ACS880-01 drives (frames R6 to R9, option +C131) installation guide (3AXD50000010497 [English]). The guide is included in the vibration damper package.

### ■ Flange mounting (option +C135)

See:

Name	Code (English)
ACS880-01...+C135 drives with flange mounting kit supplement	<a href="#">3AXD50000349814</a>
ACS880-01...+C135 frames R1 to R3 flange mounting kit quick installation guide	<a href="#">3AXD50000026158</a>
ACS880-01...+C135 frames R4 to R5 flange mounting kit quick installation guide	<a href="#">3AXD50000026159</a>
ACS880-01...+C135, ACS580-01...+C135, ACH580-01...+C135 and ACQ580-01...+C135 frames R6 to R9 flange mounting kit quick installation guide	<a href="#">3AXD50000019099</a>

### ■ UK gland plate (option +H358)

See [ACS880-01, ACS580-01, ACH580-01, ACQ580-01 UK gland plate \(+H358\) installation guide \(3AXD50000034735 \[English\]\)](#).

### ■ Cabinet installation (options +P940 and +P944)

See:

Name	Code (English)
Drive modules cabinet design and construction instructions	<a href="#">3AJUA0000107668</a>
ACS880...+P940 and +P944 drive modules supplement	<a href="#">3AJUA0000145446</a>



■ **Frames R1 to R4 (IP21, UL Type 1)**

1. See the dimensions in chapter **Dimension drawings**. Mark the locations for the four mounting holes. You can use the mounting template included in the drive package.
2. Drill the mounting holes.
3. Insert anchors or plugs into the holes and start the screws or bolts into the anchors or plugs. Drive the screws or bolts long enough into the wall to make them carry the weight of the drive.
4. Position the drive onto the bolts on the wall.
5. Tighten the bolts in the wall securely.

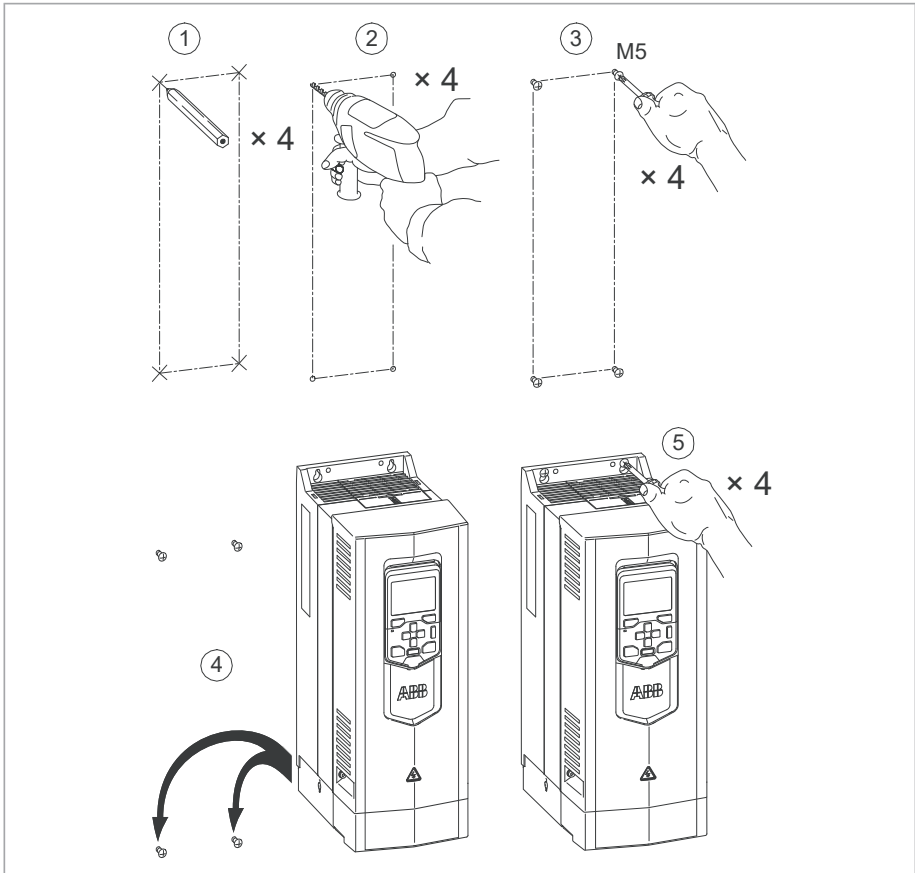

### ■ Frames R5 to R9 (IP21, UL Type 1)

1. See the dimensions in chapter [Dimension drawings](#). Mark the locations for the four or six mounting holes. You can use the mounting template included in the drive package.

**Note:** The lowest holes/mounting screws or bolts are not necessarily needed. If you use also them, you can replace the drive module without removing the cable entry box from the wall.

2. Drill the mounting holes.
3. Insert fixings anchors or plugs into the holes. Start the two upper bolts and the two lowest bolts into the anchors or plugs. Drive the bolts long enough into the wall to make them carry the weight of the drive.
4. Position the drive module onto the bolts on the wall.
5. Tighten the upper mounting bolts in the wall securely.
6. Remove the front cover.
7. Attach the cable box to the drive frame. For instructions, see the assembly drawing in the cable box. A view of frame R8 is shown below.
8. Tighten the lower mounting bolts in the wall securely.



# 58 Mechanical installation

## IP21 (UL Type 1) R5 ... R9

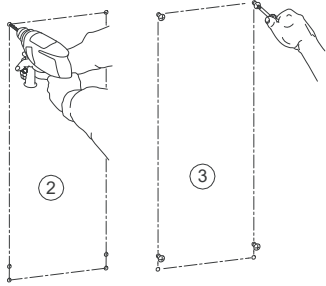
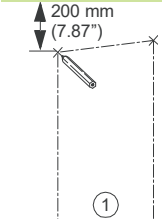

R5	M5
R6	M8
R7	M8
R8	M8
R9	M8

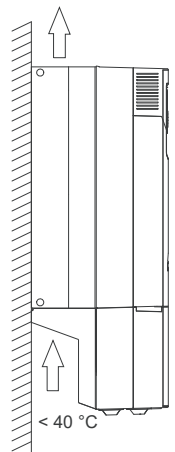
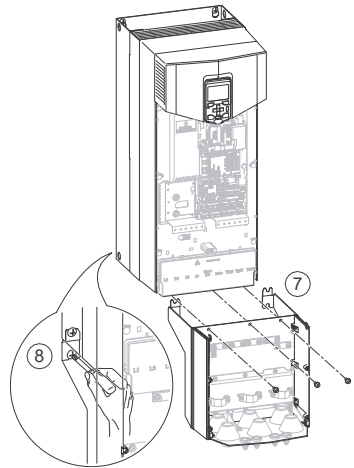
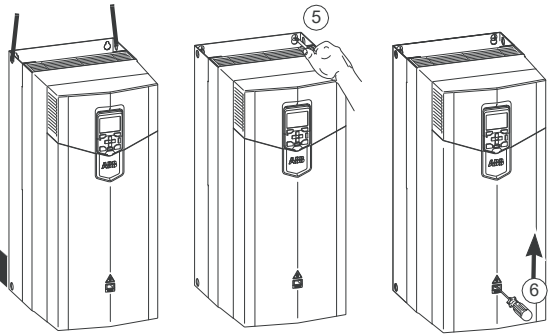
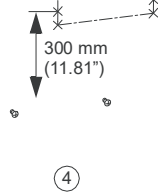

### ■ Frames R1 to R9 (IP55, UL Type 12)

**Note:** Do not open or remove the cable box for easier installation. The gaskets do not fulfill the degree of protection if the box is opened.

1. See the dimensions in chapter [Dimension drawings](#). Mark the locations for the four or six mounting holes. The lowest holes are not necessarily needed. You can use the mounting template included in the drive package.
2. Drill the mounting holes.
3. Insert fixings anchors or plugs into the holes.
4. Start the upper bolts into the mounting holes. Drive the bolts long enough into the wall to make them carry the weight of the drive.
5. Position the drive onto the upper bolts on the wall. Lift the drive with another person as it is heavy.
6. For UL Type 12 drives of frames R4 to R9: Put the hood onto the upper bolts.
7. Tighten the upper bolts in the wall securely.
8. Start the lower bolts into the mounting holes.
9. Tighten the lower bolts in the wall securely.







# 5

## Guidelines for planning the electrical installation

---

### Contents of this chapter

This chapter contains guidelines for planning the electrical installation of the drive.

### Limitation of liability

The installation must always be designed and made according to applicable local laws and regulations. ABB does not assume any liability whatsoever for any installation which breaches the local laws and/or other regulations. Furthermore, if the recommendations given by ABB are not followed, the drive may experience problems that the warranty does not cover.

### Selecting the main supply disconnecting device

You must equip the drive with a main supply disconnecting device which meets the local safety regulations. You must be able to lock the disconnecting device to the open position for installation and maintenance work.

---

### ■ European Union and United Kingdom

To meet the European Union Directives and United Kingdom Regulations, according to standard EN 60204-1, *Safety of Machinery*, the disconnecting device must be one of the following types:

- switch-disconnector of utilization category AC-23B (IEC 60947-3)
- disconnector that has an auxiliary contact that in all cases causes switching devices to break the load circuit before the opening of the main contacts of the disconnector (EN 60947-3)
- circuit-breaker suitable for isolation in accordance with IEC 60947-2.

### ■ North America

Installations must be compliant with NFPA 70 (NEC)<sup>1)</sup> and/or Canadian Electrical Code (CE) along with state and local codes for your location and application.

<sup>1)</sup> National Fire Protection Association 70 (National Electric Code).

### ■ Other regions

The disconnecting device must conform to the applicable local safety regulations.

## Selecting the main contactor

You can equip the drive with a main contactor.

Follow these guidelines when you select a customer-defined main contactor:

- Dimension the contactor according to the nominal voltage and current of the drive. Also consider the environmental conditions such as surrounding air temperature.
- IEC devices only: Select contactor with utilization category AC-1 (number of operations under load) according to IEC 60947-4, *Low-voltage switch gear and control gear*.
- Consider the application life time requirements.

### ■ North America

Installations must be compliant with NFPA 70 (NEC)<sup>1)</sup> and/or Canadian Electrical Code (CE) along with state and local codes for your location and application.

<sup>1)</sup> National Fire Protection Association 70 (National Electric Code).

### ■ Other regions

The disconnecting device must conform to the applicable local safety regulations.

---

## Examining the compatibility of the motor and drive

Use asynchronous AC induction motors, permanent magnet synchronous motors, AC induction servomotors or ABB synchronous reluctance motors (SynRM motors) with the drive.

Select the motor size and drive type from the rating table on basis of the AC line voltage and motor load. You can find the rating table in the appropriate hardware manual. You can also use the DriveSize PC tool.

Make sure that the motor can be used with an AC drive. See [Requirements tables](#) (page 63). For basics of protecting the motor insulation and bearings in drive systems, see [Protecting the motor insulation and bearings](#) (page 63).

### Note:

- Consult the motor manufacturer before using a motor with nominal voltage that differs from the AC line voltage connected to the drive input.
- The voltage peaks at the motor terminals are relative to the supply voltage of the drive, not to the drive output voltage.

### ■ Protecting the motor insulation and bearings

The drive employs modern IGBT inverter technology. Regardless of frequency, the drive output comprises pulses of approximately the drive DC bus voltage with a very short rise time. The pulse voltage can almost double at the motor terminals, depending on the attenuation and reflection properties of the motor cable and the terminals. This can cause additional stress on the motor and motor cable insulation.

Modern variable speed drives with their fast rising voltage pulses and high switching frequencies can generate current pulses that flow through the motor bearings. This can gradually erode the bearing races and rolling elements.

$du/dt$  filters protect motor insulation system and reduce bearing currents. Common mode filters mainly reduce bearing currents. Insulated N-end (non-drive end) bearings protect the motor bearings.

### ■ Requirements tables

These tables show how to select the motor insulation system and when a drive  $du/dt$  and common mode filters and insulated N-end (non-drive end) motor bearings are required. Ignoring the requirements or improper installation may shorten motor life or damage the motor bearings and voids the warranty.

---

**Requirements for ABB motors,  $P_n < 100$  kW (134 hp)**

See also Abbreviations (page 68).

Motor type	Nominal AC line voltage	Requirement for	
		Motor insulation system	ABB $du/dt$ and common mode filters, insulated N-end motor bearings
			$P_n < 100$ kW and frame size < IEC 315
			$P_n < 134$ hp and frame size < NEMA 500
Random-wound M2_, M3_ and M4_	$U_n \leq 500$ V	Standard	-
	$500$ V < $U_n \leq 600$ V	Standard	+ $du/dt$
		Reinforced	-
	$600$ V < $U_n \leq 690$ V (cable length $\leq 150$ m)	Reinforced	+ $du/dt$
$600$ V < $U_n \leq 690$ V (cable length > 150 m)	Reinforced	-	
Form-wound HX_ and AM_	$380$ V < $U_n \leq 690$ V	Standard	n.a.
Old <sup>1)</sup> form-wound HX_ and modular	$380$ V < $U_n \leq 690$ V	Check with the motor manufacturer.	+ N + $du/dt$ with voltages over 500 V + CMF
Random-wound HX_ and AM_ <sup>2)</sup>	$0$ V < $U_n \leq 500$ V	Enamelled wire with fiber glass taping	+ N + CMF
	$500$ V < $U_n \leq 690$ V		+ N + $du/dt$ + CMF
HDP	Consult the motor manufacturer.		

1) manufactured before 1.1.1998

2) For motors manufactured before 1.1.1998, check for additional instructions with the motor manufacturer.

**Requirements for ABB motors,  $P_n \geq 100$  kW (134 hp)**

See also Abbreviations (page 68).

Motor type	Nominal AC line voltage	Requirement for		
		Motor insulation system	ABB $du/dt$ and common mode filters, insulated N-end motor bearings	
			$100 \text{ kW} \leq P_n < 350 \text{ kW}$ or IEC 315 $\leq$ frame size < IEC 400	$P_n \geq 350 \text{ kW}$ or frame size $\geq$ IEC 400
			$134 \text{ hp} \leq P_n < 469 \text{ hp}$ or NEMA 500 $\leq$ frame size $\leq$ NEMA 580	$P_n \geq 469 \text{ hp}$ or frame size > NEMA 580
Random-wound M2_, M3_ and M4_	$U_n \leq 500 \text{ V}$	Standard	+ N	+ N + CMF
	$500 \text{ V} < U_n \leq 600 \text{ V}$	Standard	+ N + $du/dt$	+ N + $du/dt$ + CMF
		Reinforced	+ N	+ N + CMF
	$600 \text{ V} < U_n \leq 690 \text{ V}$ (cable length $\leq 150 \text{ m}$ )	Reinforced	+ N + $du/dt$	+ N + $du/dt$ + CMF
$600 \text{ V} < U_n \leq 690 \text{ V}$ (cable length > 150 m)	Reinforced	+ N	+ N + CMF	
Form-wound HX_ and AM_	$380 \text{ V} < U_n \leq 690 \text{ V}$	Standard	+ N + CMF	$P_n < 500 \text{ kW}$ : + N + CMF
				$P_n \geq 500 \text{ kW}$ : + N + $du/dt$ + CMF
Old <sup>1)</sup> form-wound HX_ and modular	$380 \text{ V} < U_n \leq 690 \text{ V}$	Check with the motor manufacturer.	+ N + $du/dt$ with voltages over 500 V + CMF	
Random-wound HX_ and AM_ <sup>2)</sup>	$0 \text{ V} < U_n \leq 500 \text{ V}$	Enamelled wire with fiber glass taping	+ N + CMF	
	$500 \text{ V} < U_n \leq 690 \text{ V}$		+ N + $du/dt$ + CMF	
HDP	Consult the motor manufacturer.			

1) manufactured before 1.1.1998

2) For motors manufactured before 1.1.1998, check for additional instructions with the motor manufacturer.

**Requirements for non-ABB motors,  $P_n < 100 \text{ kW}$  (134 hp)**

See also Abbreviations (page 68).

Motor type	Nominal AC line voltage	Requirement for	
		Motor insulation system	ABB $du/dt$ and common mode filters, insulated N-end motor bearings
			$P_n < 100 \text{ kW}$ and frame size $< \text{IEC 315}$
			$P_n < 134 \text{ hp}$ and frame size $< \text{NEMA 500}$
Random-wound and form-wound	$U_n \leq 420 \text{ V}$	Standard: $\hat{U}_{LL} = 1300 \text{ V}$	-
	$420 \text{ V} < U_n \leq 500 \text{ V}$	Standard: $\hat{U}_{LL} = 1300 \text{ V}$	+ $du/dt$
		Reinforced: $\hat{U}_{LL} = 1600 \text{ V}$ , 0.2 $\mu\text{s}$ rise time	-
	$500 \text{ V} < U_n \leq 600 \text{ V}$	Reinforced: $\hat{U}_{LL} = 1600 \text{ V}$	+ $du/dt$
		Reinforced: $\hat{U}_{LL} = 1800 \text{ V}$	-
	$600 \text{ V} < U_n \leq 690 \text{ V}$	Reinforced: $\hat{U}_{LL} = 1800 \text{ V}$	+ $du/dt$
		Reinforced: $\hat{U}_{LL} = 2000 \text{ V}$ , 0.3 $\mu\text{s}$ rise time <sup>1)</sup>	-

<sup>1)</sup> If the intermediate DC circuit voltage of the drive is increased from the nominal level due to long term resistor braking cycles, check with the motor manufacturer if additional output filters are needed.

**Requirements for non-ABB motors,  $P_n \geq 100$  kW (134 hp)**

See also Abbreviations (page 68).

Motor type	Nominal AC line voltage	Requirement for		
		Motor insulation system	ABB du/dt and common mode filters, insulated N-end motor bearings	
			$100 \text{ kW} \leq P_n < 350 \text{ kW}$ or IEC 315 $\leq$ frame size < IEC 400	$P_n \geq 350 \text{ kW}$ or frame size $\geq$ IEC 400
			$134 \text{ hp} \leq P_n < 469 \text{ hp}$ or NEMA 500 $\leq$ frame size $\leq$ NEMA 580	$P_n \geq 469 \text{ hp}$ or frame size > NEMA 580
Random-wound and form-wound	$U_n \leq 420 \text{ V}$	Standard: $\hat{U}_{LL} = 1300 \text{ V}$	+ N or CMF	+ N + CMF
	$420 \text{ V} < U_n \leq 500 \text{ V}$	Standard: $\hat{U}_{LL} = 1300 \text{ V}$	+ du/dt + (N or CMF)	+ N + du/dt + CMF
		Reinforced: $\hat{U}_{LL} = 1600 \text{ V}$ , 0.2 $\mu\text{s}$ rise time	+ N or CMF	+ N + CMF
	$500 \text{ V} < U_n \leq 600 \text{ V}$	Reinforced: $\hat{U}_{LL} = 1600 \text{ V}$	+ du/dt + (N or CMF)	+ N + du/dt + CMF
		Reinforced: $\hat{U}_{LL} = 1800 \text{ V}$	+ N or CMF	+ N + CMF
	$600 \text{ V} < U_n \leq 690 \text{ V}$	Reinforced: $\hat{U}_{LL} = 1800 \text{ V}$	+ du/dt + N	+ N + du/dt + CMF
		Reinforced: $\hat{U}_{LL} = 2000 \text{ V}$ , 0.3 $\mu\text{s}$ rise time <sup>1)</sup>	+ N + CMF	+ N + CMF

<sup>1)</sup> If the intermediate DC circuit voltage of the drive is increased from the nominal level due to long term resistor braking cycles, check with the motor manufacturer if additional output filters are needed.

**Abbreviations**

Abbr.	Definition
$U_n$	Nominal AC line voltage
$\hat{U}_{LL}$	Peak line-to-line voltage at motor terminals which the motor insulation must withstand
$P_n$	Motor nominal power
$du/dt$	$du/dt$ filter at the output of the drive
CMF	Common mode filter of the drive
N	N-end bearing: insulated motor non-drive end bearing
n.a.	Motors of this power range are not available as standard units. Consult the motor manufacturer.

**Availability of  $du/dt$  filter and common mode filter by drive type**

Product type	Availability of $du/dt$ filter	Availability of common mode filter (CMF)
ACS880-01	Ordered separately, see chapter <i>Filters</i> (page 313)	Plus code option +E208

**Additional requirements for explosion-safe (EX) motors**

If you use an explosion-safe (EX) motor, obey the rules in the requirements table above. In addition, consult the motor manufacturer for any further requirements.

**Additional requirements for ABB motors of types other than M2\_, M3\_, M4\_, HX\_ and AM\_**

Use the selection criteria given for non-ABB motors.

**Additional requirements for braking applications**

When the motor brakes the machinery, the intermediate circuit DC voltage of the drive increases, the effect being similar to the motor supply voltage increasing by up to 20 percent. Consider this voltage increase when specifying the motor insulation requirements if the motor will be braking a large part of its operation time.

Example: Motor insulation requirement for a 400 V AC line voltage application must be selected as if the drive were supplied with 480 V.

**Additional requirements for ABB high-output and IP23 motors**

The rated output power of high output motors is higher than what is stated for the particular frame size in EN 50347 (2001).

This table shows the requirements for protecting the motor insulation and bearings in drive systems for ABB random-wound motor series (for example, M3AA, M3AP and M3BP).



Nominal AC supply voltage	Requirement for			
	Motor insulation system	ABB du/dt and common mode filters, insulated N-end motor bearings		
		$P_n < 100 \text{ kW}$	$100 \text{ kW} \leq P_n < 200 \text{ kW}$	$P_n \geq 200 \text{ kW}$
		$P_n < 140 \text{ hp}$	$140 \text{ hp} \leq P_n < 268 \text{ hp}$	$P_n \geq 268 \text{ hp}$
$U_n \leq 500 \text{ V}$	Standard	-	+ N	+ N + CMF
$500 \text{ V} < U_n \leq 600 \text{ V}$	Standard	+ du/dt	+ du/dt + N	+ du/dt + N + CMF
	or Reinforced	-	+ N	+ N + CMF
$600 \text{ V} < U_n \leq 690 \text{ V}$	Reinforced	+ du/dt	+ du/dt + N	+ du/dt + N + CMF

### Additional requirements for non-ABB high-output and IP23 motors

The rated output power of high-output motors is higher than what is stated for the particular frame size in EN 50347 (2001).

If you plan to use a non-ABB high-output motor or an IP23 motor, consider these additional requirements for protecting the motor insulation and bearings in drive systems:

- If motor power is below 350 kW: Equip the drive and/or motor with the filters and/or bearings according to the table below.
- If motor power is above 350 kW: Consult the motor manufacturer.

70 Guidelines for planning the electrical installation

Nominal AC supply voltage	Requirement for		
	Motor insulation system	ABB du/dt and common mode filters, insulated N-end motor bearings	
		$P_n < 100 \text{ kW}$ or frame size < IEC 315	$100 \text{ kW} < P_n < 350 \text{ kW}$ or IEC 315 < frame size < IEC 400
	$P_n < 134 \text{ hp}$ or frame size < NEMA 500	$134 \text{ hp} < P_n < 469 \text{ hp}$ or NEMA 500 < frame size < NEMA 580	
$U_n \leq 420 \text{ V}$	Standard: $\hat{U}_{LL} = 1300 \text{ V}$	+ N or CMF	+ N or CMF
$420 \text{ V} < U_n < 500 \text{ V}$	Standard: $\hat{U}_{LL} = 1300 \text{ V}$	+ du/dt + (N or CMF)	+ N + du/dt + CMF
	or Reinforced: $\hat{U}_{LL} = 1600 \text{ V}$ , 0.2 micro-second rise time	+ N or CMF	+ N or CMF
$500 \text{ V} < U_n \leq 600 \text{ V}$	Reinforced: $\hat{U}_{LL} = 1600 \text{ V}$	+ du/dt + (N or CMF)	+ N + du/dt + CMF
	or Reinforced: $\hat{U}_{LL} = 1800 \text{ V}$	+ N or CMF	+ N + CMF
$600 \text{ V} < U_n \leq 690 \text{ V}$	Reinforced: $\hat{U}_{LL} = 1800 \text{ V}$	+ N + du/dt	+ N + du/dt + CMF
	Reinforced: $\hat{U}_{LL} = 2000 \text{ V}$ , 0.3 micro-second rise time <sup>1)</sup>	+ N + CMF	+ N + CMF

<sup>1)</sup> If the intermediate DC circuit voltage of the drive is increased from the nominal level due to long term resistor braking cycles, check with the motor manufacturer if additional output filters are needed.

**Additional data for calculating the rise time and the peak line-to-line voltage**

The diagrams below show the relative peak line-to-line voltage and rate of change of voltage as a function of the motor cable length. If you need to calculate the actual peak voltage and voltage rise time considering the actual cable length, proceed as follows:

- Peak line-to line voltage: Read the relative  $\hat{U}_{LL}/U_n$  value from the diagram below and multiply it by the nominal supply voltage ( $U_n$ ).
- Voltage rise time: Read the relative values  $\hat{U}_{LL}/U_n$  and  $(du/dt)/U_n$  from the diagram below. Multiply the values by the nominal supply voltage ( $U_n$ ) and substitute into equation  $t = 0.8 \cdot \hat{U}_{LL}/(du/dt)$ .

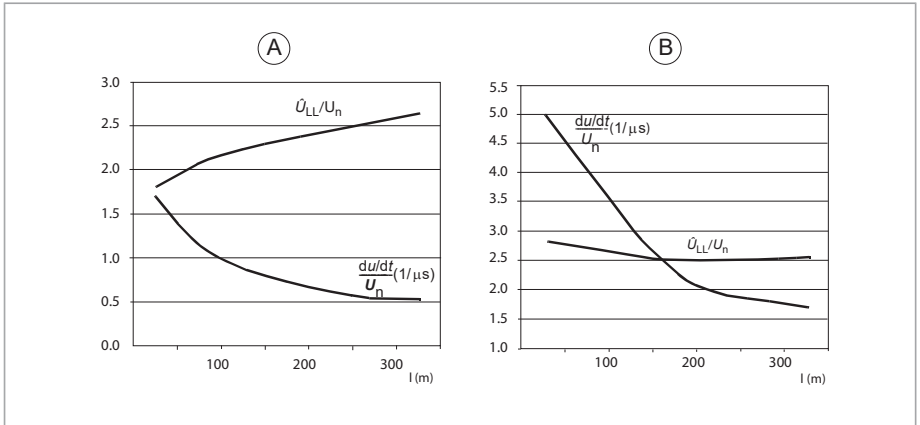

A	Drive with $du/dt$ filter
B	Drive without $du/dt$ filter
$l$	Motor cable length
$\hat{U}_{LL}/U_n$	Relative peak line-to-line voltage
$(du/dt)/U_n$	Relative $du/dt$ value
<b>Note:</b> $\hat{U}_{LL}$ and $du/dt$ values are approximately 20% higher with resistor braking.	

**Additional note for sine filters**

A sine filter also protects the motor insulation system. The peak phase-to-phase voltage with a sine filter is approximately  $1.5 \cdot U_n$ .

## Selecting the power cables

### ■ General guidelines

Select the input power and motor cables according to local regulations.

- **Current:** Select a cable capable of carrying the maximum load current and suitable for the prospective short-circuit provided by the supply network. The method of installation and ambient temperature affect the cable current carrying capacity. Obey local regulations and laws.
- **Temperature:** For an IEC installation, select a cable rated for at least 70 °C (158 °F) maximum permissible temperature of conductor in continuous use. For North America, select a cable rated for at least 75 °C (167 °F).  
Important: For certain product types or option configurations higher temperature rating may be required. See the technical data for details.
- **Voltage:** 600 V AC cable is accepted for up to 500 V AC. 750 V AC cable is accepted for up to 600 V AC. 1000 V AC cable is accepted for up to 690 V AC.

To comply with the EMC requirements of the CE mark, use one of the preferred cable types. See [Preferred power cable types \(page 72\)](#).

Symmetrical shielded cable reduces electromagnetic emission of the whole drive system as well as the stress on motor insulation, bearing currents and wear.

Metal conduit reduces electromagnetic emission of the whole drive system.

### ■ Typical power cable sizes

See the technical data.

### ■ Power cable types

#### Preferred power cable types

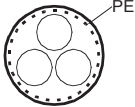

This section presents the preferred cable types. Make sure that the selected cable type also complies with local/state/country electrical codes.

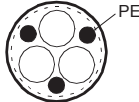
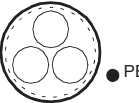
Cable type	Use as input power cabling	Use as motor cabling
 <p data-bbox="90 1305 370 1433">Symmetrical shielded (or armored) cable with three phase conductors and concentric PE conductor as shield (or armor)</p>	Yes	Yes





Cable type	Use as input power cabling	Use as motor cabling
 <p>Symmetrical shielded (or armored) cable with three phase conductors and symmetrically constructed PE conductor and a shield (or armor)</p>	Yes	Yes
 <p>Symmetrical shielded (or armored) cable with three phase conductors and a shield (or armor), and separate PE conductor/cable<sup>1)</sup></p>	Yes	Yes

1) A separate PE conductor is required if the conductivity of the shield (or armor) is not sufficient for the PE use.

### Alternate power cable types

Cable type	Use as input power cabling	Use as motor cabling
 <p>Four-conductor cabling in PVC conduit or jacket (three phase conductors and PE)</p>	Yes with phase conductor smaller than 10 mm <sup>2</sup> (8 AWG) Cu.	Yes with phase conductor smaller than 10 mm <sup>2</sup> (8 AWG) Cu, or motors up to 30 kW (40 hp). <b>Note:</b> Shielded or armored cable, or cabling in metal conduit is always recommended to minimize radio frequency interference.
 <p>Four-conductor cabling in metal conduit (three phase conductors and PE). For example, EMT, or four-conductor armored cable</p>	Yes	Yes with phase conductor smaller than 10 mm <sup>2</sup> (8 AWG) Cu, or motors up to 30 kW (40 hp)

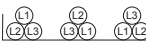
74 Guidelines for planning the electrical installation

Cable type	Use as input power cabling	Use as motor cabling
 <p>Shielded (Al/Cu shield or armor)<sup>1)</sup> four-conductor cable (three phase conductors and a PE)</p>	<p>Yes</p>	<p>Yes with motors up to 100 kW (135 hp). A potential equalization between the frames of motor and driven equipment is required.</p>
 <p>A single-core cable system: three phase conductors and PE conductor on cable tray</p>  <p>Preferable cable arrangement to avoid voltage or current unbalance between the phases</p>	<p>Yes</p> <p> <b>WARNING!</b> If you use unshielded single-core cables in an IT network, make sure that the non-conductive outer sheath (jacket) of the cables have good contact with a properly grounded conductive surface. For example, install the cables on a properly grounded cable tray. Otherwise voltage may become present on the non-conductive outer sheath of the cables, and there is even a risk of an electric shock.</p>	<p>No</p>

<sup>1)</sup> Armor may act as an EMC shield, as long as it provides the same performance as a concentric EMC shield of a shielded cable. To be effective at high frequencies, the shield conductivity must be at least 1/10 of the phase conductor conductivity. The effectiveness of the shield can be evaluated based on the shield inductance, which must be low and only slightly dependent on frequency. The requirements are easily met with a copper or aluminum shield/armor. The cross-section of a steel shield must be ample and the shield helix must have a low gradient. A galvanized steel shield has a better high-frequency conductivity than a non-galvanized steel shield.

**Not allowed power cable types**

Cable type	Use as input power cabling	Use as motor cabling
 <p>Symmetrical shielded cable with individual shields for each phase conductor</p>	<p>No</p>	<p>No</p>

## ■ Additional guidelines, North America

ABB recommends the use of metallic conduit for power wiring. ABB also recommends the use of symmetrical shielded VFD cable between drive and motor(s).

This table shows examples of methods for wiring the drive. Refer to NEC 70 along with state and local codes for the appropriate methods for your application.

Wiring method	Notes
Conduit - Metallic <sup>1) 2)</sup>	
Electrical metallic tubing: Type EMT	Prefer symmetrical shielded VFD cable. Use separate conduit run for each motor. Do not run input power wiring and motor wiring in the same conduit.
Rigid metal conduit: Type RMC	
Liquid-tight flexible metal electrical conduit: Type LFMC	
Conduit - Non-metallic <sup>2) 3)</sup>	
Liquid-tight flexible non-metallic conduit: Type LFNC	Prefer symmetrical shielded VFD cable. Use separate conduit run for each motor. Do not run input power wiring and motor wiring in the same conduit.
Wireways <sup>2)</sup>	
Metallic	Prefer symmetrical shielded VFD cable. Separate motor wiring from input power wiring and other low voltage wiring. Do not run outputs of multiple drives parallel. Bundle each cable (wiring) together and use separators where possible.
Free air <sup>2)</sup>	
Enclosures, air handlers, etc.	Prefer symmetrical shielded VFD cable. Allowed internally in enclosures when in accordance with UL.

1) Metallic conduit may be used as an additional ground path, provided this path is a solid path capable of handling ground currents.

2) See NFPA NEC 70, UL, and local codes for your application.

3) Non-metallic conduit use underground is allowed; however, these installations inherently have an increased chance for nuisance problems due to the potential for water/moisture in the conduit. Water/moisture in the conduit increases the likelihood of VFD faults or warnings. Proper installation is required to make sure there is no intrusion of water/moisture.

## Metal conduit

Couple separate parts of a metal conduit together: bridge the joints with a ground conductor bonded to the conduit on each side of the joint. Also bond the conduits to the drive enclosure and motor frame. Use separate conduits for input power, motor, brake resistor, and control wiring. Do not run motor wiring from more than one drive in the same conduit.

■ **Power cable shield**

If the cable shield is used as the sole protective earth (PE) conductor, make sure that its conductivity agrees with the PE conductor requirements.

To effectively suppress radiated and conducted radio-frequency emissions, the cable shield conductivity must be at least 1/10 of the phase conductor conductivity. The requirements are easily met with a copper or aluminum shield. The minimum requirement of the motor cable shield of the drive is shown below. It consists of a concentric layer of copper wires with an open helix of copper tape or copper wire. The better and tighter the shield, the lower the emission level and bearing currents.

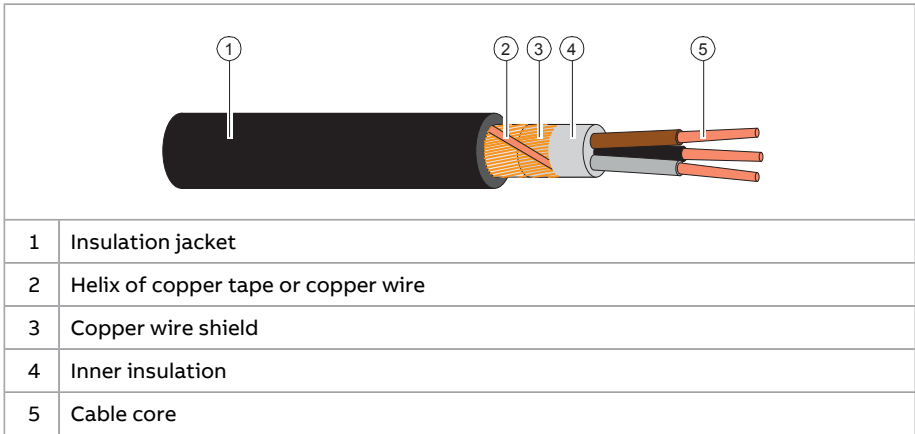

**Grounding requirements**

This section gives general requirements for grounding the drive. When you plan the grounding of the drive, obey all the applicable national and local regulations.

The conductivity of the protective earth conductor(s) must be sufficient.

Unless local wiring regulations state otherwise, the cross-sectional area of the protective earth conductor must agree with the conditions that require automatic disconnection of the supply required in 411.3.2 of IEC 60364-4-41:2005 and be capable of withstanding the prospective fault current during the disconnection time of the protective device. The cross-sectional area of the protective earth conductor must be selected from the table below or calculated according to 543.1 of IEC 60364-5-54.

This table shows the minimum cross-sectional area of the protective earth conductor related to the phase conductor size according to IEC/UL 61800-5-1 when the phase conductor(s) and the protective earth conductor are made of the same metal. If this is not so, the cross-sectional area of the protective earth



conductor must be determined in a manner which produces a conductance equivalent to that which results from the application of this table.

Cross-sectional area of the phase conductors $S$ (mm <sup>2</sup> )	Minimum cross-sectional area of the corresponding protective earth conductor $S_p$ (mm <sup>2</sup> )
$S \leq 16$	$S$ <sup>1)</sup>
$16 < S \leq 35$	16
$35 < S$	$S/2$

<sup>1)</sup> For the minimum conductor size in IEC installations, refer to *Additional grounding requirements – IEC*.

If the protective earth conductor is not part of the input power cable or input power cable enclosure, the minimum permitted cross-sectional area is:

- 2.5 mm<sup>2</sup> if the conductor is mechanically protected,  
or
- 4 mm<sup>2</sup> if the conductor is not mechanically protected. If the equipment is cord-connected, the protective earth conductor must be the last conductor to be interrupted if there is a failure in the strain relief mechanism.

#### ■ Additional grounding requirements – IEC

This section gives grounding requirements according to standard IEC/EN 61800-5-1.

Because the normal touch current of the drive is more than 3.5 mA AC or 10 mA DC:

- the minimum size of the protective earth conductor must comply with the local safety regulations for high protective earth conductor current equipment, and
- you must use one of these connection methods:
  1. a fixed connection and:
    - a protective earth conductor with a minimum cross-sectional area of 10 mm<sup>2</sup> Cu or 16 mm<sup>2</sup> Al (as an alternative when aluminum cables are permitted),  
or
    - a second protective earth conductor of the same cross-sectional area as the original protective earth conductor,  
or
    - a device that automatically disconnects the supply if the protective earth conductor is damaged.
  2. a connection with an industrial connector according to IEC 60309 and a minimum protective earth conductor cross-section of 2.5 mm<sup>2</sup> as part of a multi-conductor power cable. Sufficient strain relief must be provided.

If the protective earth conductor is routed through a plug and socket, or similar means of disconnection, it must not be possible to disconnect it unless power is simultaneously removed.

**Note:** You can use power cable shields as grounding conductors only when their conductivity is sufficient.

■ **Additional grounding requirements – UL (NEC)**

This section gives grounding requirements according to standard UL 61800-5-1.

The protective earth conductor must be sized as specified in Article 250.122 and table 250.122 of the National Electric Code, ANSI/NFPA 70.

For cord-connected equipment, it must not be possible to disconnect the protective earth conductor before power is removed.

## Selecting the control cables

■ **Shielding**

Only use shielded control cables.

Use a double-shielded twisted pair cable for analog signals. ABB recommends this type of cable also for the pulse encoder signals. Use one individually shielded pair for each signal. Do not use common return for different analog signals.

A double-shielded cable (a) is the best alternative for low-voltage digital signals, but single-shielded (b) twisted pair cable is also acceptable.

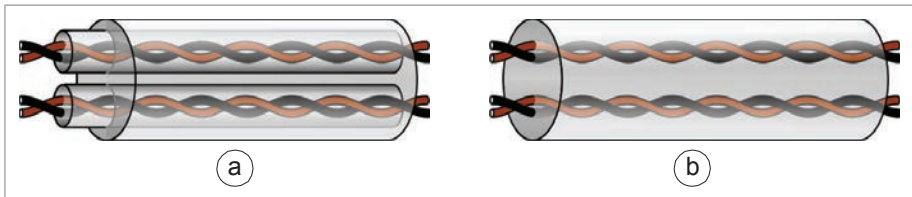

■ **Signals in separate cables**

Run analog and digital signals in separate, shielded cables. Do not mix 24 V DC and 115/230 V AC signals in the same cable.

■ **Signals that can be run in the same cable**

If their voltage does not exceed 48 V, relay-controlled signals can be run in the same cables as digital input signals. The relay-controlled signals should be run as twisted pairs.

### ■ Relay cable

The cable type with braided metallic shield (for example ÖLFLEX by LAPPKABEL, Germany) has been tested and approved by ABB.

### ■ Control panel to drive cable

Use EIA-485, Cat 5e (or better) cable with male RJ-45 connectors. The maximum length of the cable is 100 m (328 ft).

### ■ PC tool cable

Connect the Drive Composer PC tool to the drive through the USB port of the control panel. Use a USB Type A (PC) - Type Mini-B (control panel) cable. The maximum length of the cable is 3 m (9.8 ft).

## Routing the cables

### ■ General guidelines – IEC

- Route the motor cable away from other cables. Motor cables of several drives can be run in parallel installed next to each other.
- Install the motor cable, input power cable and control cables on separate trays.
- Avoid long parallel runs of motor cables with other cables.
- Where control cables must cross power cables, make sure that they are arranged at an angle as near to 90 degrees as possible.
- Do not run extra cables through the drive.
- Make sure that the cable trays have good electrical bonding to each other and to the grounding electrodes. Aluminum tray systems can be used to improve local equalizing of potential.

The following figure illustrates the cable routing guidelines with an example drive.

## 80 Guidelines for planning the electrical installation

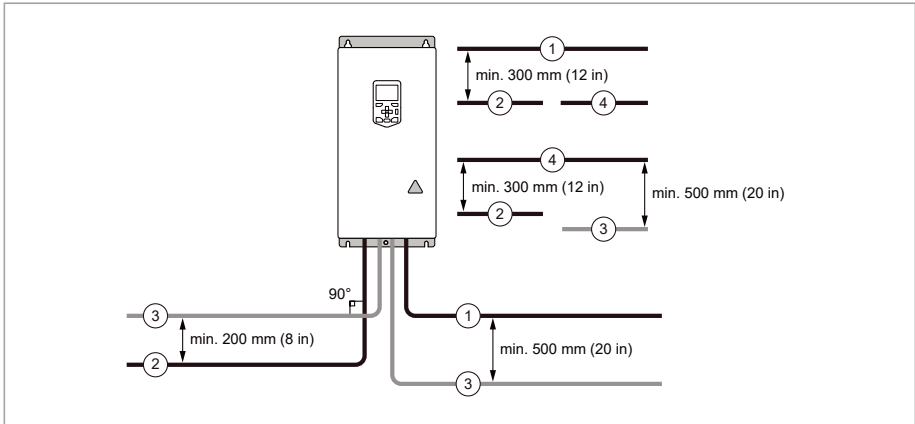

1	Motor cable
2	Input power cable
3	Control cable
4	Brake resistor or chopper cable (if any)

### ■ General guidelines – North America

Make sure that the installation is in accordance with national and local codes. Obey these general guidelines:

- Use separate conduits for the input power, motor, brake resistor (optional), and control cabling.
- Use separate conduit for each motor cabling.

The following figure illustrates the cable routing guidelines with an example drive.

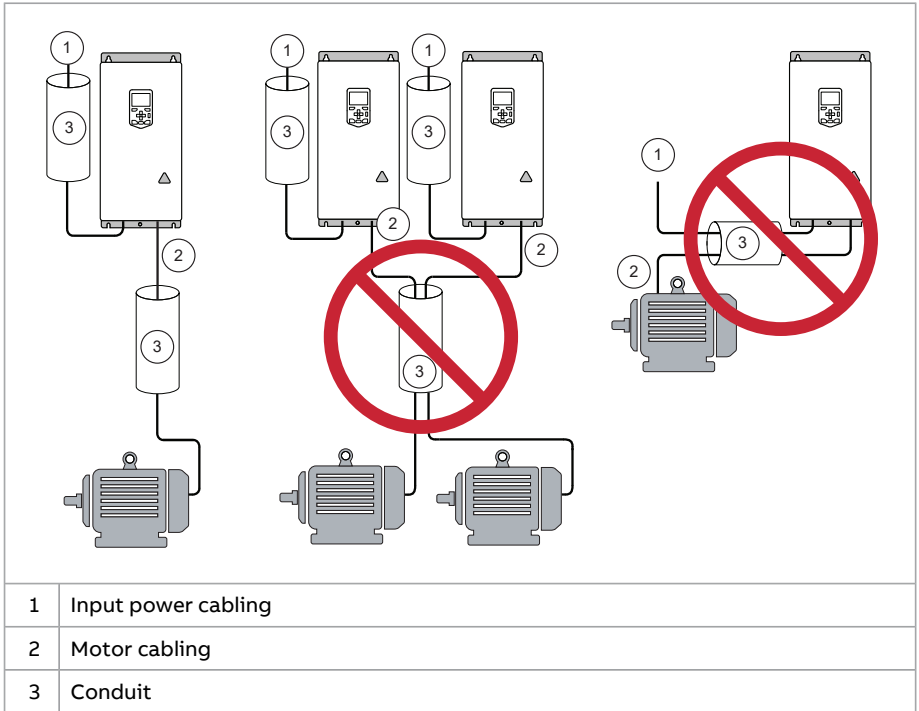

■ **Continuous motor cable shield/conduit or enclosure for equipment on the motor cable**

To minimize the emission level when safety switches, contactors, connection boxes or similar equipment are installed on the motor cable between the drive and the motor:

- Install the equipment in a metal enclosure.
- Use either a symmetrical shielded cable, or install the cabling in a metal conduit.
- Make sure that there is a good and continuous galvanic connection in the shield/conduit between drive and motor.
- Connect the shield/conduit to the protective ground terminal of the drive and the motor.

■ **Separate control cable ducts**

Put 24 V DC and 230 V AC (120 V AC) control cables in separate ducts, unless the 24 V DC cable is insulated for 230 V AC (120 V AC) or insulated with an insulation sleeving for 230 V AC (120 V AC).

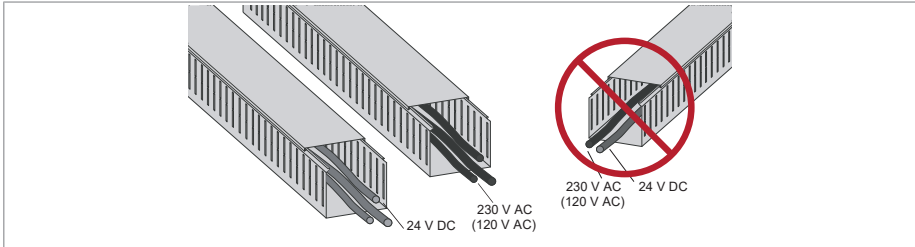

**Implementing short-circuit and thermal overload protection**

■ **Protecting the drive and the input power cable in short-circuits**

Protect the drive with fuses and the input cable with fuses or a circuit breaker.

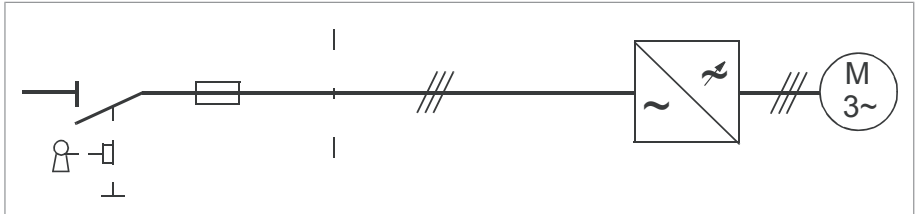

Size the fuses or circuit breakers according to local regulations for the input cable protection. Select the fuses or circuit breakers for the drive according to the instructions given in the technical data. The fuses for the drive protection will restrict drive damage and prevent damage to adjoining equipment in case of a short-circuit inside the drive.

**Note:** If the fuses or circuit breakers for the drive protection are placed at the distribution board and the input cable is dimensioned according to the nominal input current of the drive given in the technical data, the fuses or circuit breakers protect also the input cable in short-circuit situations, restrict drive damage and prevent damage to adjoining equipment in case of a short-circuit inside the drive. No separate fuses or circuit breakers for the input cable protection are needed.

**⚡ WARNING!** Due to the inherent operating principle and construction of circuit breakers, independent of the manufacturer, hot ionized gases can escape from the breaker enclosure in case of a short-circuit. To ensure safe use, pay special attention to the installation and placement of the breakers. Obey the manufacturer's instructions.

### ■ Protecting the motor and motor cable in short-circuits

The drive protects the motor cable and motor in a short-circuit situation when:

- the motor cable is sized correctly
- the motor cable type complies with the motor cable selection guidelines by ABB drives
- the cable length does not exceed the allowed maximum length specified for the drive
- the motor nominal power (99.10) setting in the drive is equal with the value given on the motor rating plate.

The electronic power output short-circuit protection circuitry meets the requirements of IEC 60364-4-41 2005/AMD1.

### ■ Protecting the drive against thermal overload

The drive has overload protection as standard.

### ■ Protecting the input power cable against thermal overload

The drive has overload protection as standard. If the sizing of the input power cable is correct, the drive overload protection protects also the cable against overload. In case of parallel input power cables, it may be necessary to protect each cable separately. Obey the local regulations.

### ■ Protecting the motor cables against thermal overload

The drive protects the motor cables against thermal overload when the cables are sized according to the nominal output current of the drive. No additional thermal protection devices are needed.



#### **WARNING!**

If the drive is connected to multiple motors, use a separate overload protection for each motor cable and motor. The drive overload protection is tuned for the total motor load. It may not detect an overload in one motor circuit only.

North America: The local code (NEC) requires an overload protection and a short-circuit protection for each motor circuit. Use, for example:

- a manual motor protector
- circuit breaker, contactor and overload relay or
- fuses, contactor and overload relay.

### ■ **Protecting the motor against thermal overload**

According to regulations, the motor must be protected against thermal overload and the current must be switched off when overload is detected. The drive includes a motor thermal protection function that protects the motor and switches off the current when necessary. Depending on a drive parameter value, the function either monitors a calculated temperature value (based on a motor thermal model) or an actual temperature indication given by motor temperature sensors.

The motor thermal protection model supports thermal memory retention and speed sensitivity. The user can tune the thermal model further by feeding in additional motor and load data.

The most common temperature sensor types are PTC or Pt100.

For more information, see the firmware manual.

### ■ **Protecting the motor against overload without thermal model or temperature sensors**

Motor overload protection protects the motor against overload without using motor thermal model or temperature sensors.

Motor overload protection is required and specified by multiple standards including the US National Electric Code (NEC) and the common UL/IEC 61800-5-1 standard in conjunction with UL/IEC 60947-4-1. The standards allow for motor overload protection without external temperature sensors.

The protection feature allows the user to specify the class of operation in the same manner as the overload relays are specified in standards UL/IEC 60947-4-1 and NEMA ICS 2.

The motor overload protection supports thermal memory retention and speed sensitivity.

For more information, see drive firmware manual.

## **Protecting the drive against ground faults**

The drive is equipped with an internal ground fault protective function to protect the unit against ground faults in the motor and motor cable. This function is not a personnel safety or a fire protection feature. See the firmware manual for more information.

### ■ **Residual current device compatibility**

The drive is suitable for use with residual current devices of Type B.

**Note:** As standard, the drive contains capacitors connected between the main circuit and the frame. These capacitors and long motor cables increase the ground leakage current and may cause nuisance faults in residual current devices.

---



## Connecting drives to a common DC system

See [Common DC systems with ACS880-01, -04, -11, -14, -31 and -34 drives application guide \(3AUA0000127818 \[English\]\)](#).

## Implementing the emergency stop function

For safety reasons, install the emergency stop devices at each operator control station and at other operating stations where the emergency stop may be needed. Implement the emergency stop according to relevant standards.

**Note:** You can use the Safe torque off function of the drive to implement the Emergency stop function.

## Implementing the Safe torque off function

See [The Safe torque off function \(page 293\)](#).

## Implementing the functions provided by the FSO safety functions module

You can order the drive with an FSO-12 safety functions module (option +Q973) or FSO-21 safety functions module (option +Q972). An FSO module enables the implementation of functions such as Safe brake control (SBC), Safe stop 1 (SS1), Safe stop emergency (SSE), Safely limited speed (SLS) and Safe maximum speed (SMS).

The settings of the FSO module have default values when delivered from the factory. The wiring of the external safety circuit and configuration of the FSO module are the responsibility of the user.

The FSO module reserves the standard Safe torque off (STO) connection of the drive control unit. STO can still be utilized by other safety circuits through the FSO module.

See the appropriate manual for more information.

Name	Code
FSO-12 safety functions module user's manual	<a href="#">3AXD50000015612</a>
FSO-21 safety functions module user's manual	<a href="#">3AXD50000015614</a>

## Implementing an ATEX-certified motor thermal protection

With option +Q971, the drive provides ATEX-certified safe motor disconnection without contactor using the drive Safe torque off function. To implement the thermal protection of a motor in explosive atmosphere (Ex motor), you must also:

- use an ATEX-certified Ex motor

- order an ATEX-certified thermistor protection module for the drive (option +L537), or acquire and install an ATEX-compliant protection relay
- do the necessary connections.

For more information, see:

User's manual	Manual code (English)
ATEX-certified Safe disconnection function, Ex II (2) GD for ACS880 drives (+Q971) application guide	<a href="#">3AUAA0000132231</a>
FPTC-02 ATEX-certified thermistor protection module, Ex II (2) GD (option +L537+Q971) for ACS880 drives user's manual	<a href="#">3AXD50000027782</a>

## Implementing the power loss ride-through function

If the incoming supply voltage is cut off, the drive will continue to operate by utilizing the kinetic energy of the rotating motor. The drive will be fully operational as long as the motor rotates and generates energy to the drive.

If you equip the drive with a main contactor or breaker, make sure that it restores the drive input power after a short break. The contactor must either re-connect after the break automatically, or remain closed over the break. Depending on the contactor control circuit design, this can require an additional hold circuit, uninterruptible auxiliary power supply or auxiliary power supply buffering.

**Note:** If the power loss lasts so long that the drive trips on undervoltage, a fault reset and a fresh start command is required to continue operation.

Implement the power-loss ride-through function as follows:

1. Enable the power-loss ride-through function of the drive (parameter 30.31).
2. If the installation is equipped with a main contactor, prevent its tripping at the input power break. For example, use a time delay relay (hold) in the contactor control circuit.
3. Enable the automatic restart of the motor after a short power supply break:
  - Set the start mode to automatic (parameter 21.01 or 21.19, depending on the motor control mode being used).
  - Define the automatic restart time (parameter 21.18).



**WARNING!**

Make sure that a flying restart of the motor will not cause any danger. If you are in doubt, do not implement the power loss ride-through function.

## Using power factor compensation capacitors with the drive

Power factor compensation is not needed with AC drives. However, if a drive is to be connected in a system with compensation capacitors installed, note the following restrictions.



### **WARNING!**

Do not connect power factor compensation capacitors or harmonic filters to the motor cables (between the drive and the motor). They are not meant to be used with AC drives and can cause permanent damage to the drive or themselves.

---

If there are power factor compensation capacitors in parallel with the input of the drive:

1. Do not connect a high-power capacitor to the power line while the drive is connected. The connection will cause voltage transients that may trip or even damage the drive.
2. If capacitor load is increased/decreased step by step when the AC drive is connected to the power line, make sure that the connection steps are low enough not to cause voltage transients that would trip the drive.
3. Make sure that the power factor compensation unit is suitable for use in systems with AC drives, ie, harmonic generating loads. In such systems, the compensation unit should typically be equipped with a blocking reactor or harmonic filter.

## Controlling a contactor between drive and motor

The control of the output contactor depends on how you use the drive, that is, which motor control mode and which motor stop mode you select.

If you have the DTC motor control mode and the motor ramp stop mode selected, use this operation sequence to open the contactor:

1. Give a stop command to the drive.
2. Wait until the drive decelerates the motor to zero speed.
3. Open the contactor.

If you have the DTC motor control mode and the motor coast stop, or scalar control mode selected, open the contactor as follows:

1. Give a stop command to the drive.
  2. Open the contactor.
-



**WARNING!**

When the DTC motor control mode is in use, never open the output contactor while the drive controls the motor. The DTC motor control operates extremely fast, much faster than it takes for the contactor to open its contacts. When the contactor starts opening while the drive controls the motor, the DTC control will try to maintain the load current by immediately increasing the drive output voltage to the maximum. This will damage, or even burn, the contactor completely.

---

## Implementing a bypass connection

If bypassing is required, employ mechanically or electrically interlocked contactors between the motor and the drive and between the motor and the power line. Make sure with interlocking that the contactors cannot be closed simultaneously. The installation must be clearly marked as defined in IEC/EN 61800-5-1, subclause 6.5.3, for example, “THIS MACHINE STARTS AUTOMATICALLY”.

---



**WARNING!**

Never connect the drive output to the electrical power network. The connection may damage the drive.

---

### ■ Example bypass connection

An example bypass connection is shown below.

---

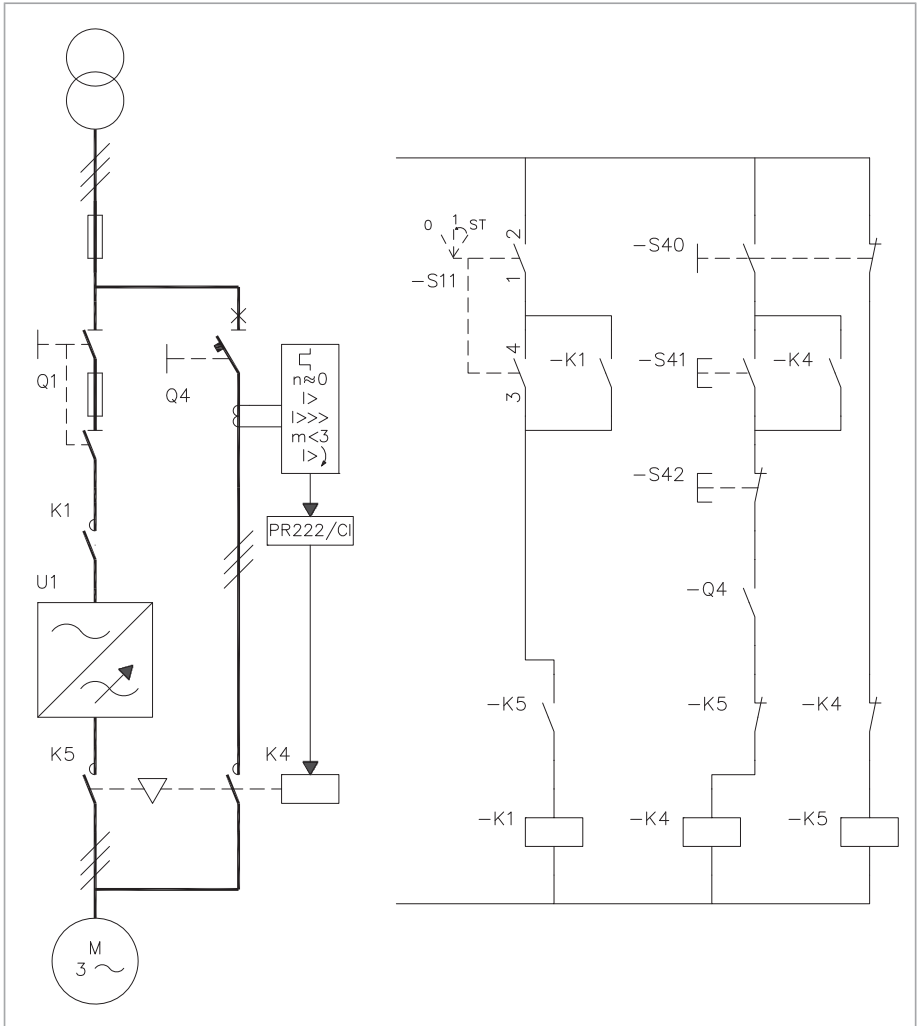

Q1	Drive main switch	S11	Drive main contactor on/off control
Q4	Bypass circuit breaker	S0	Motor power supply selection (drive or direct-on-line)
K1	Drive main contactor	S41	Start when motor is connected direct-on-line
K4	Bypass contactor	S42	Stop when motor is connected direct-on-line
K5	Drive output contactor	-	-

### **Switching the motor power supply from drive to direct-on-line**

1. Stop the drive and the motor with the drive control panel (drive in local control mode) or with the external stop signal (drive in remote control mode).
2. Open the main contactor of the drive with S11.
3. Switch the motor power supply from the drive to direct-on-line with S40.
4. Wait for 10 seconds to allow the motor magnetization to die away.
5. Start the motor with S41.

### **Switching the motor power supply from direct-on-line to drive**

1. Stop the motor with S42.
2. Switch the motor power supply from direct-on-line to the drive with S40.
3. Close the main contactor of the drive with switch S11 (-> turn to position ST for two seconds and leave at position 1).
4. Start the drive and the motor with the drive control panel (drive in local control mode) or with the external start signal (drive in remote control mode).

## **Protecting the contacts of relay outputs**

Inductive loads (relays, contactors, motors) cause voltage transients when switched off.

The relay contacts on the drive control unit are protected with varistors (250 V) against overvoltage peaks. In spite of this, it is highly recommended that inductive loads are equipped with noise attenuating circuits (varistors, RC filters [AC] or diodes [DC]) to minimize the EMC emission at switch-off. If not suppressed, the disturbances may connect capacitively or inductively to other conductors in the control cable and form a risk of malfunction in other parts of the system.

Install the protective component as close to the inductive load as possible. Do not install protective components at the relay outputs.

---

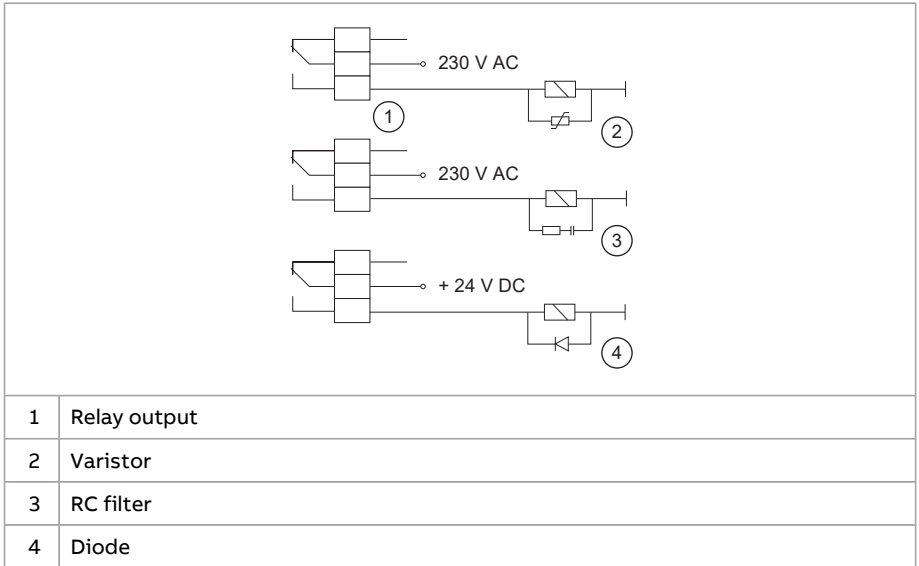

## Implementing a motor temperature sensor connection



### WARNING!

IEC 61800-5-1 requires double or reinforced insulation between live parts and accessible parts when:

- the accessible parts are not conductive, or
- the accessible parts are conductive, but not connected to the protective earth.

Obey this requirement when you plan the connection of the motor temperature sensor to the drive.

To connect a motor temperature sensor and other similar components to the drive, you have four alternatives:

1. If there is double or reinforced insulation between the sensor and the live parts of the motor, you can connect the sensor directly to the inputs of the drive.
2. If there is basic insulation between the sensor and the live parts of the motor, you can connect the sensor to the analog/digital inputs of the drive if all circuits connected to the drive's digital and analog inputs (typically extra-low voltage circuits) are protected against contact and insulated with basic insulation from other low-voltage circuits. The insulation must be rated for the same voltage level as the drive main circuit. Note that extra-low voltage circuits (such as 24 V DC) typically do not meet these requirements.

3. You can connect the sensor to the drive via an option module. The sensor and the module must form a double or reinforced insulation between the motor live parts and the drive control unit. See section [Connection of motor temperature sensor to the drive via an option module \(page 100\)](#).
4. You can connect the sensor to a digital input of the drive via a customer’s external relay. The sensor and the relay must form a double or reinforced insulation between the motor live parts and the drive control unit. See section [Connection of motor temperature sensor to the drive via a relay \(page 101\)](#).

**■ Connecting a motor temperature sensor to the drive through an option module**

This table shows:

- option module types that you can use for the motor temperature sensor connection
- insulation or isolation level that each option module forms between its temperature sensor connector and other connectors
- temperature sensor types that you can connect to each option module
- temperature sensor insulation requirement in order to form, together with the insulation of the option module, a reinforced insulation between the motor live parts and the drive control unit.

Option module		Temperature sensor type			Temperature sensor insulation requirement
Type	Insulation/Isolation	PTC	KTY	Pt100, Pt1000	
FIO-11	Galvanic isolation between sensor connector and drive control unit connector. No isolation between sensor connector and other I/O connectors.	x	x	x	Reinforced insulation
FIO-21	Galvanic isolation between sensor connector and other connectors (including drive control unit connector).	x	x	x	Reinforced insulation
FEN-01	Galvanic isolation between sensor connector and drive control unit connector. No isolation between sensor connector and TTL encoder emulation output.	x	-	-	Reinforced insulation



Option module		Temperature sensor type			Temperature sensor insulation requirement
Type	Insulation/Isolation	PTC	KTY	Pt100, Pt1000	
FEN-11	Galvanic isolation between sensor connector and drive control unit connector. No isolation between sensor connector and TTL encoder emulation output.	x	x	-	Reinforced insulation
FEN-21	Galvanic isolation between sensor connector and drive control unit connector. No isolation between sensor connector and TTL encoder emulation output.	x	x	-	Reinforced insulation
FEN-31	Galvanic isolation between sensor connector and drive control unit connector. No isolation between sensor connector and other connectors.	x	x	-	Reinforced insulation
FAIO-01	Basic insulation between sensor connector and drive control unit connector. No insulation between sensor connector and other I/O connectors.	x	x	x	Reinforced or basic insulation. With basic insulation, the other I/O connectors of the option module must be kept disconnected.
FPTC-01/02 <sup>1)</sup>	Reinforced insulation between sensor connector and other connectors (including drive control unit connector).	x	-	-	No special requirement

<sup>1)</sup> Suitable for use in safety functions (SIL2 / PL c rated).

For more information, refer to the applicable option module user's manual.

## ■ Connection of motor temperature sensor to the drive via a relay

### PTC (IEC 60800-5-1)

Class A. This table shows the insulation requirement for a customer's external relay, and the insulation requirement for the sensor to fulfill decisive voltage class A (double insulation).

PTC relay		Temperature sensor insulation requirement
Type	Insulation	
External relay	Basic insulation 6 kV	Basic insulation

Class B. Decisive voltage class B (basic insulation) is provided with a 6 kV relay. Circuits connected to all motor protection relay inputs and outputs must be protected against direct contact.

**Pt100 (IEC 90800-5-1)**

Class B. Decisive voltage class B (basic insulation) can be achieved when there is basic insulation between the sensor and live parts of the motor. Circuits connected to all motor protection relay inputs and outputs must be protected against direct contact.

P100 relay		Temperature sensor insulation requirement between sensor and live parts of motor
Type	Insulation	
External relay	Basic insulation 6 kV	Basic insulation

## 6

# Electrical installation – Global (IEC)

---

## Contents of this chapter

This chapter gives instructions on wiring the drive.

## Safety

---

**WARNING!**

If you are not a qualified electrical professional, do not do installation or maintenance work. Obey the safety instructions of the drive. If you ignore them, injury or death, or damage to the equipment can occur.

---

## Required tools

To do the electrical installation, you need these tools:

- wire stripper
- screwdriver set (Torx, flat and/or Phillips, as appropriate)
- torque wrench.

## Grounding the motor cable shield at the motor end

For minimum radio-frequency interference, ground the cable shield 360 degrees at the cable entry of the motor terminal box.

---



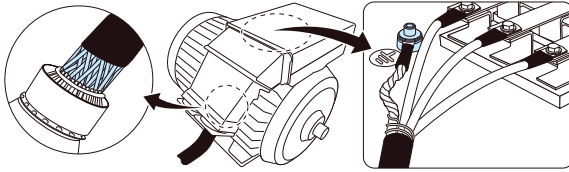

## Measuring the insulation

### ■ Measuring the insulation resistance of the drive



#### **WARNING!**

Do not do any voltage withstand or insulation resistance tests on any part of the drive as testing can damage the drive. Every drive has been tested for insulation between the main circuit and the chassis at the factory. Also, there are voltage-limiting circuits inside the drive which cut down the testing voltage automatically.

### ■ Measuring the insulation resistance of the input power cable

Before you connect the input power cable to the drive, measure its insulation resistance according to local regulations.

### ■ Measuring the insulation resistance of the motor and motor cable



#### **WARNING!**

Obey the safety instructions of the drive. If you ignore them, injury or death, or damage to the equipment can occur. If you are not a qualified electrical professional, do not do installation, commissioning or maintenance work.

1. Do the steps in section [Electrical safety precautions \(page 18\)](#) before you start the work.
2. Make sure that the motor cable is disconnected from the drive output terminals.
3. Measure the insulation resistance between each phase conductor and the protective earth conductor. Use a measuring voltage of 1000 V DC. The insulation resistance of an ABB motor must be more than 100 Mohm (reference value at 25 °C [77 °F]). For the insulation resistance of other motors, refer to the manufacturer's instructions.

**Note:** Moisture inside the motor reduces the insulation resistance. If you think that there is moisture in the motor, dry the motor and do the measurement again.

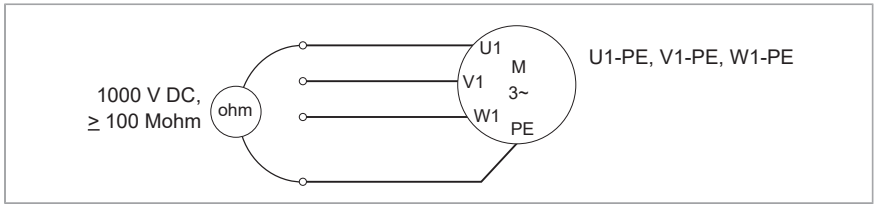

## ■ Measuring the insulation resistance of the brake resistor circuit



### WARNING!

Obey the safety instructions of the drive. If you ignore them, injury or death, or damage to the equipment can occur. If you are not a qualified electrical professional, do not do installation, commissioning or maintenance work.

1. Stop the drive and do the steps in section [Electrical safety precautions](#) (page 18) before you start the work.
2. Make sure that the resistor cable is connected to the resistor and disconnected from the drive output terminals.
3. At the drive end, connect the R+ and R- conductors of the resistor cable together. Measure the insulation resistance between the conductors and the PE conductor with a measuring voltage of 1000 V DC. The insulation resistance must be more than 1 Mohm.

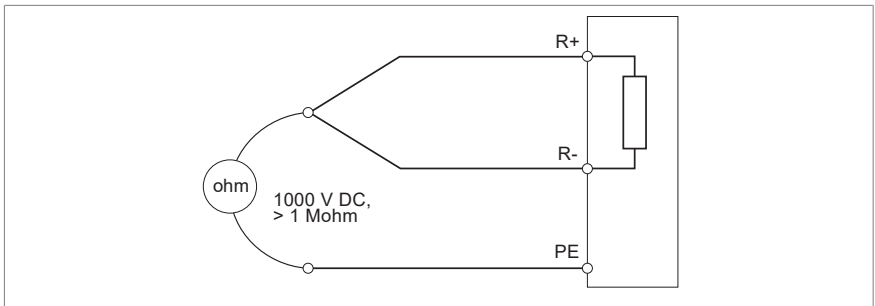

## Grounding system compatibility check

The standard drive can be installed to a symmetrically grounded TN-S system. If you install the drive to another system, you may need to disconnect the EMC filter and ground-to-phase varistor. See [ACS880 frames R1 to R11 EMC filter and ground-to-phase varistor disconnecting instructions \(3AUA0000125152 \[English\]\)](#).



**WARNING!** Do not install the drive with EMC filter options +E200 or +E202 connected to a system that the filter is not suitable for. This can cause danger, or damage the drive.

---



**WARNING!** Do not install the drive with the ground-to-phase varistor connected to a system that the varistor is not suitable for. If you do, the varistor circuit can be damaged.

---

■ **Corner-grounded and midpoint-grounded 525...690 V delta systems**

---



**WARNING!** Do not install the drive on a 525...690 V corner-grounded or midpoint-grounded delta system. Disconnecting the EMC filter and ground-to-phase varistor does not prevent damage to the drive.

---



## Connecting the power cables

### ■ Connection diagram

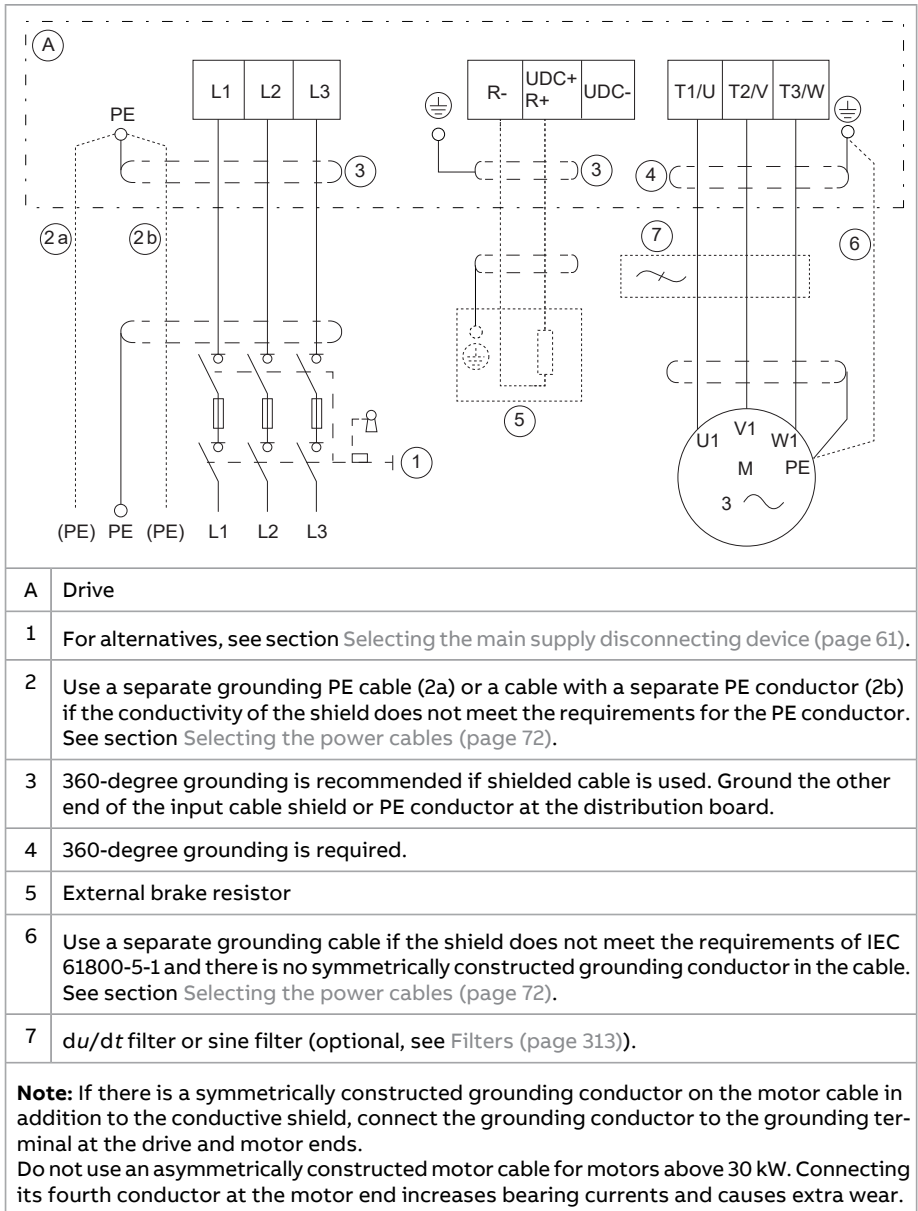

### ■ Connection procedure for frames R1 to R3

1. Undo the mounting screws at the sides of the front cover.
2. Remove the cover by sliding it forward.
3. Attach the residual voltage warning sticker in the local language to the control panel mounting platform.
4. Remove the rubber grommets from the entry plate for the cables to be connected.
5. IP21 drives: Attach the Romex clamps (included in the delivery in a plastic bag) to the cable entry plate holes.
6. Prepare the input power and motor cable ends as illustrated in the figure.  
**Note:** Bare shield will be grounded 360 degrees.
7. IP21 drives: Ground the shields 360 degrees in the Romex clamps by tightening the connector onto the stripped part of the cable. IP55 drives: Tighten the clamps onto the stripped part of the cables. Mind the sharp edges.
8. Connect the twisted shields of the power cables to the grounding terminals.
9. Connect the additional PE conductor (if used, see page 19) of the input cable to the grounding terminal.
10. Connect the phase conductors of the input cable to the L1, L2 and L3 terminals and the phase conductors of the motor cable to the T1/U, T2/V and T3/W terminals. Connect the brake resistor conductors (if present) to the R+ and R- terminals. Tighten the screws to the torque given in the figure below.
11. Install the control cable grounding shelf in the cable entry box.
12. Attach the cables outside the drive mechanically.





R1...R3

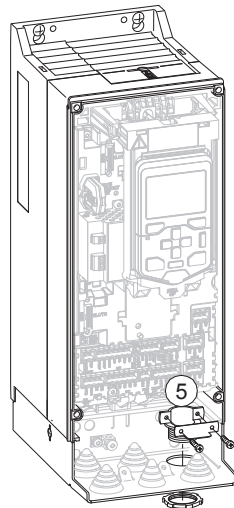
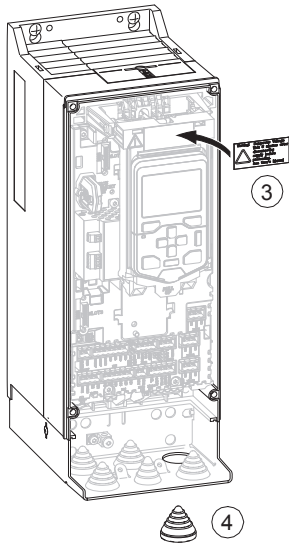
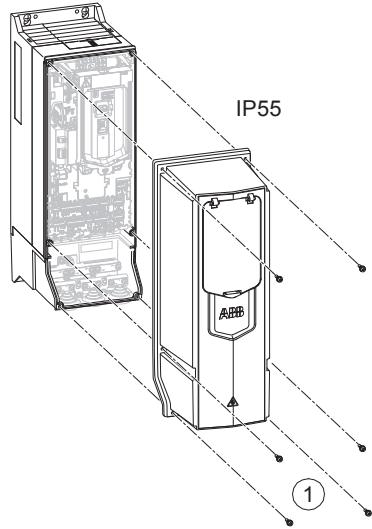
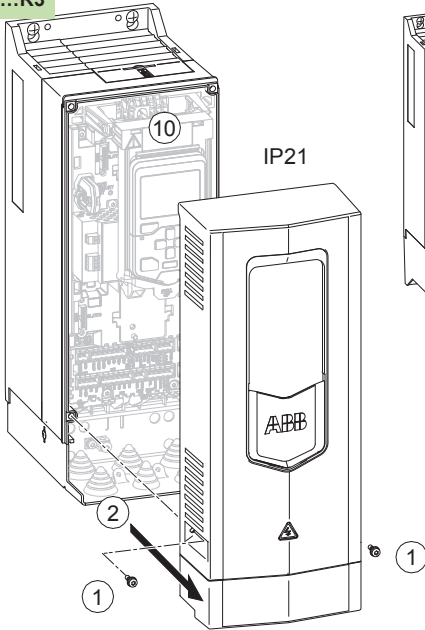

R1...R3

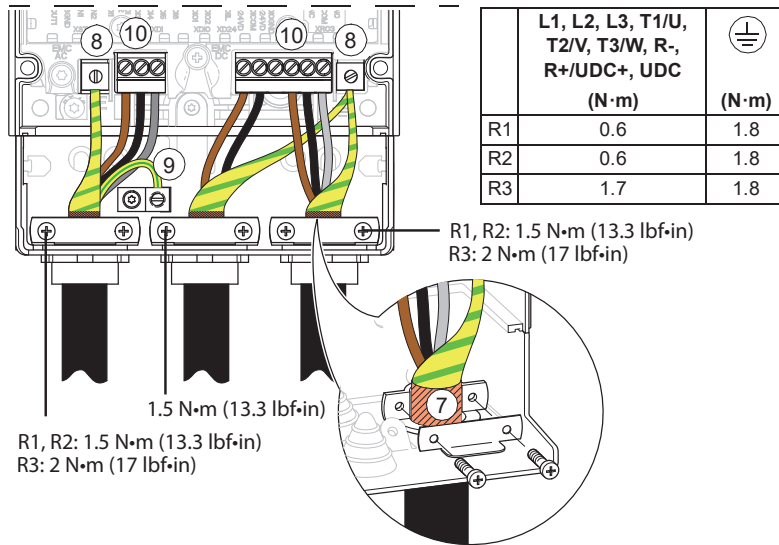
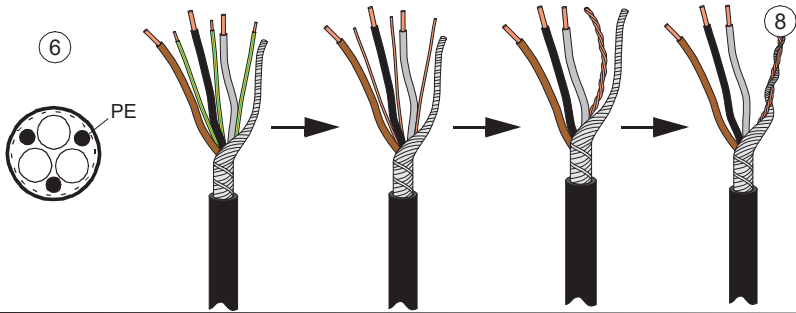
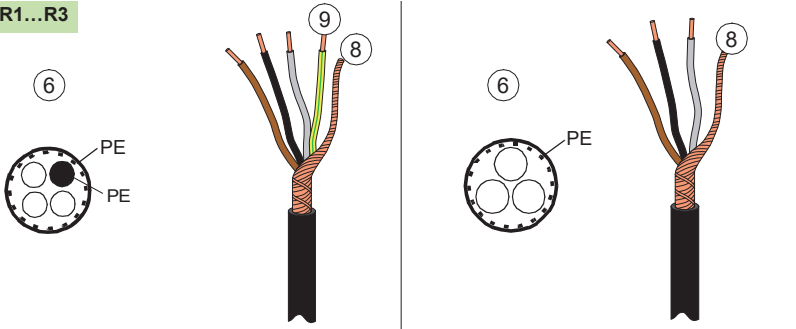

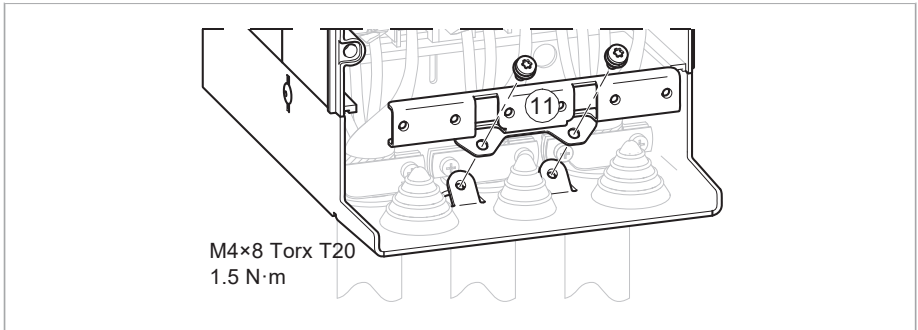

### ■ Connection procedure for frames R4 and R5

1. Remove the front cover. IP21 drives: Release the retaining clip with a screwdriver (a) and lift the cover from the bottom outwards (b).
2. For IP21 drives: Remove the cable entry box cover by undoing the mounting screw.
3. For frame R4: Remove the EMC shroud that separates the input and output cabling if needed for easier installation.
4. Remove the shroud on the power cable terminals by releasing the clips and lifting the shroud up from the sides with a screwdriver (a). Knock out holes in the shroud for the cables to be installed (b).
5. Attach the residual voltage warning sticker in the local language next to the control unit top.
6. Cut adequate holes into the rubber grommets. Slide the grommets onto the cables. Slide the cables through the holes of the bottom plate and attach the grommets to the holes.
7. Prepare the ends of the input power and motor cables as illustrated in the figure. Bare shield will be grounded 360 degrees under the grounding clamp.
8. Ground the cable shields 360 degrees under the grounding clamps. Mind the sharp edges.
9. Connect the twisted cable shields to the grounding terminals.
10. Connect the phase conductors of the input cable to the L1, L2 and L3 terminals and the phase conductors of the motor cable to the T1/U, T2/V and T3/W terminals. Tighten the screws to the torque given in the figure below.



**Note: For cable lug installation (frame R5):** Detach the connector and install a cable lug to the terminal post as follows:

- Remove the combi screw that attaches the connector to its terminal post and pull the connector off.
- Attach the cable lug to the conductor.
- Put the cable lug onto the terminal post. Start the nut, and turn it at least two rotations by hand.



**WARNING!**

Before you use tools, make sure that the nut/screw is not cross-threading. Cross-threading will damage the drive and cause danger.

- 
- Undo the nut that attaches the connector to its terminal post and pull the connector off.
  - Attach the cable lug to the conductor.
  - Put the cable lug onto the terminal post. Start the nut, and turn it at least two rotations by hand.



**WARNING!** Before you use tools, make sure that the nut/screw is not cross-threading. Cross-threading will damage the drive and cause danger.

- 
- Tighten the nut to a torque of 5 N·m.
11. Install the EMC shroud separating the input and output cabling if not installed yet.
  12. Drives with option +D150: Slide the brake resistor cable through the brake resistor and control cable clamp assembly. Connect the conductors to the R+ and R- terminals and tighten to the torque given in the figure.
  13. Reinstall the shroud on the power terminals.
  14. Attach the cables outside the unit mechanically. Install the rubber grommets to the unused entry plate holes.



R4, R5

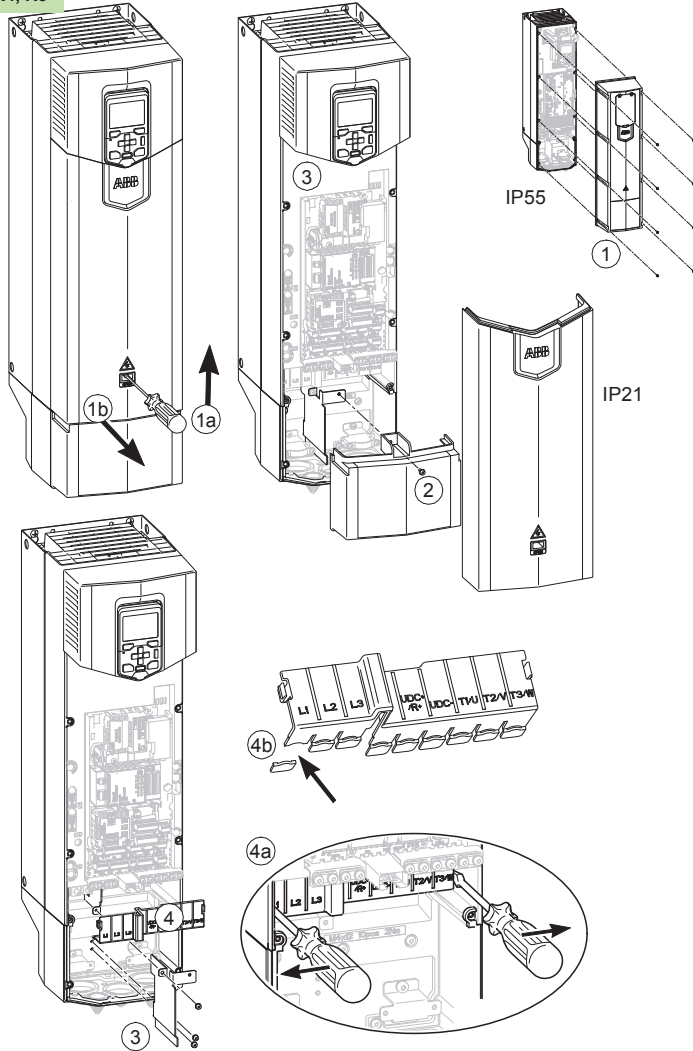

R4, R5

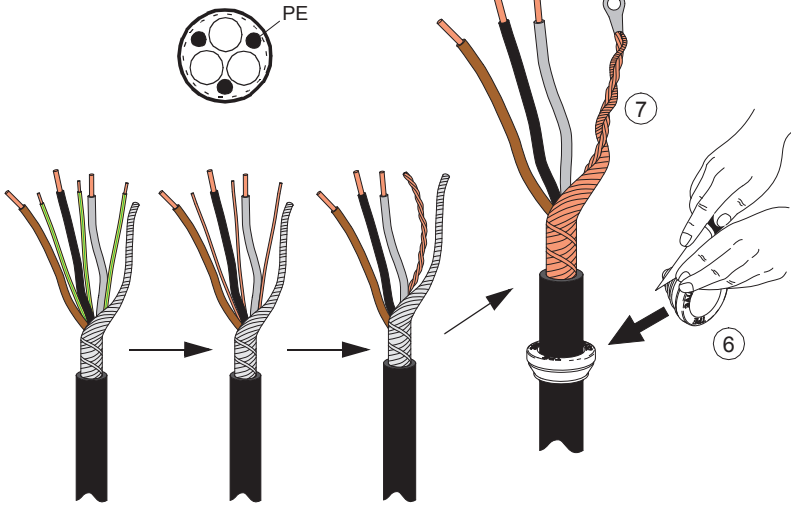
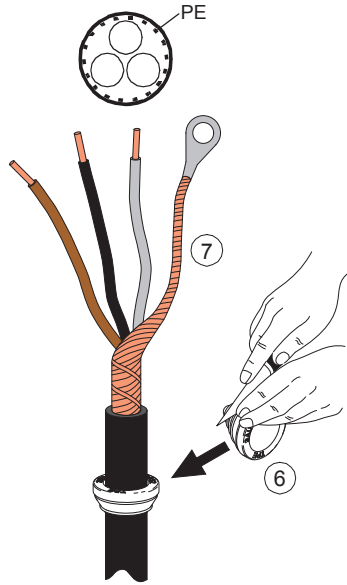
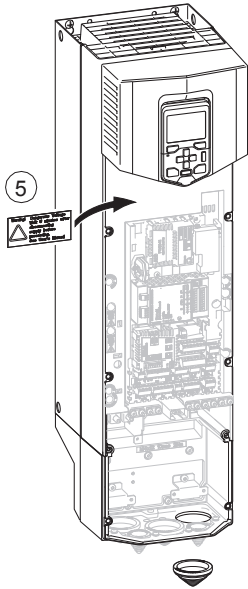

R4, R5

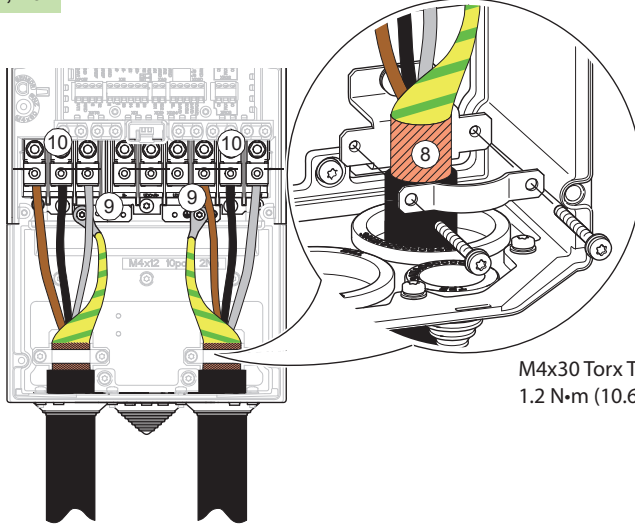

M4x30 Torx T20  
1.2 N·m (10.6 lbf·in)

	L1, L2, L3, T1/U, T2/V, T3/W (N·m)	R-, R+/UDC+, UDC- (N·m)	 (N·m)
R4	3.3	3.3	2.9
R5	15	15	2.9

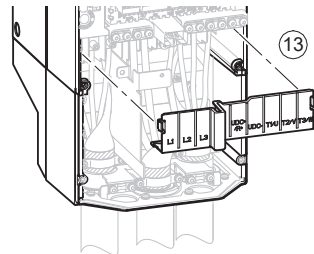
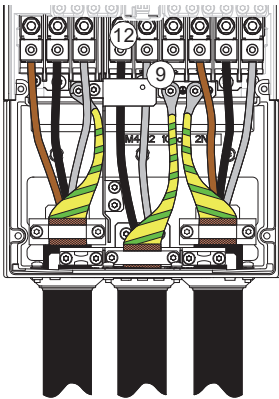
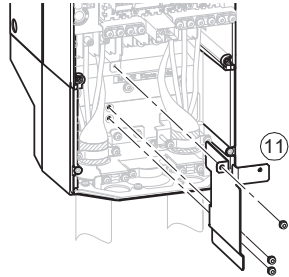

### ■ Connection procedure for frames R6 to R9

**Note: For frames R6 to R9 with option +H358, see also [ACS880-01](#), [ACS580-01](#), [ACH580-01](#), [ACQ580-01](#) UK gland plate (+H358) installation guide ([3AXD50000034735 \[English\]](#)).**

1. Remove the front cover: For IP21 drives: Release the retaining clip with a screwdriver (a) and pull the cover by the bottom outwards (b).
2. For IP21 drives: Remove the cable entry box cover by undoing the mounting screws.
3. Attach the residual voltage warning sticker in the local language next to the control unit.
4. Remove the side plates of the cable entry box by undoing the mounting screws.
5. Remove the shroud on the power cable terminals by releasing the clips on the sides with a screwdriver and lifting (a). Knock out holes for the cables to be installed (b).
6. If parallel cables are installed (frames R8 and R9): Knock out the shrouds on the power cable terminals for the cables to be installed.
7. Prepare the ends of the input power and motor cables as illustrated in the figure. The bare shield will be grounded 360 degrees under the clamp.
8. Cut adequate holes into the rubber grommets (a). Slide the grommets onto the cables. Slide the cables through the holes of the bottom plate and attach the grommets to the holes (b).
9. Tighten the clamp onto the stripped part of the cable. Mind the sharp edges.
10. Attach the twisted shields of the cables under the grounding clamps.
11. Connect the phase conductors of the input cable to the L1, L2 and L3 terminals and the phase conductors of the motor cable to the T1/U, T2/V and T3/W terminals. Tighten the screws to the torque given in the figure.





**Note:** Frames R8 and R9: If you put only one conductor to the connector, ABB recommends that you put it under the upper pressure plate.

**Note: Detaching connectors (frames R8 and R9)**

- ABB does not recommend that you detach the connectors. If you do, detach and reinstall the connector as follows.

L1, L2 and L3 connectors

- a. Remove the combi screw that attaches the connector to its terminal post, and pull the connector off.
- b. Put the conductor under the connector pressure plate and pretighten the conductor.
- c. Put the connector back onto the terminal post. Start the combi screw, and turn it at least two rotations by hand.



**WARNING!** Before you use tools, make sure that the nut/screw is not cross-threading. Cross-threading will damage the drive and cause danger.

---

- d. Tighten the combi screw to a torque of 30 N·m.
- e. Tighten the conductor(s) to 40 N·m for frame R8 or to 70 N·m for frame R9.

T1/U, T2/V and T3/W connectors

- a. Remove the nut that attaches the connector to its busbar.
- b. Put the conductor under the connector pressure plate and pretighten the conductor.
- c. Put the connector back to its busbar. Start the nut, and turn it at least two rotations by hand.



**WARNING!** Before you use tools, make sure that the nut/screw is not cross-threading. Cross-threading will damage the drive and cause danger.

---

- d. Tighten the nut to a torque of 30 N·m.
- e. Tighten the conductor(s) to 40 N·m for frame R8 or to 70 N·m for frame R9.



**Note: Cable lug installation (frames R6 to R9):** Detach the connector and install a cable lug to the terminal post / busbar as follows:

- L1, L2, L3: Undo the nut that attaches the connector to the terminal post, and pull the connector off.  
R-, R+, U/T1, V/T2, W/T3: Remove the combi screw that attaches the connector to its terminal post / busbar, and pull the connector off.
- Attach the cable lug to the conductor.
- L1, L2, L3: Put the cable lug onto the terminal post / busbar. Start the nut, and turn it at least two rotations by hand.



**WARNING!** Before you use tools, make sure that the nut/screw is not cross-threading. Cross-threading will damage the drive and cause danger.

---

- Tighten the nut to a torque of 16 N·m (frames R6 and R7) and to a torque of 30 N·m (frames R8 and R9).
12. Drives with option +D150: Connect the brake resistor cable conductors to the R+ and R- terminals.
  13. If parallel cables are installed (frames R8 and R9), install the grounding shelves for them. Repeat steps 8 to 12.
  14. Reinstall the shroud on the power terminals.
  15. Reinstall the side plates of the cable entry box.
  16. Install the control cable grounding shelf in the cable entry box.
  17. Attach the cables outside the drive mechanically. Install the rubber grommets to the unused entry plate holes.



R6 ... R9

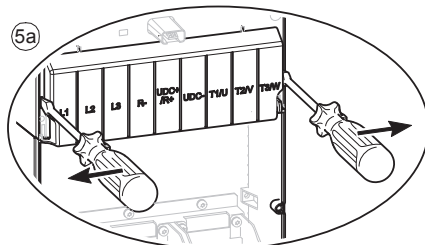
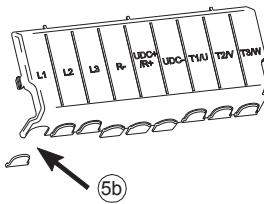
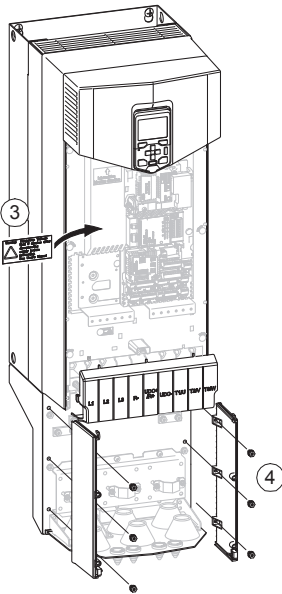
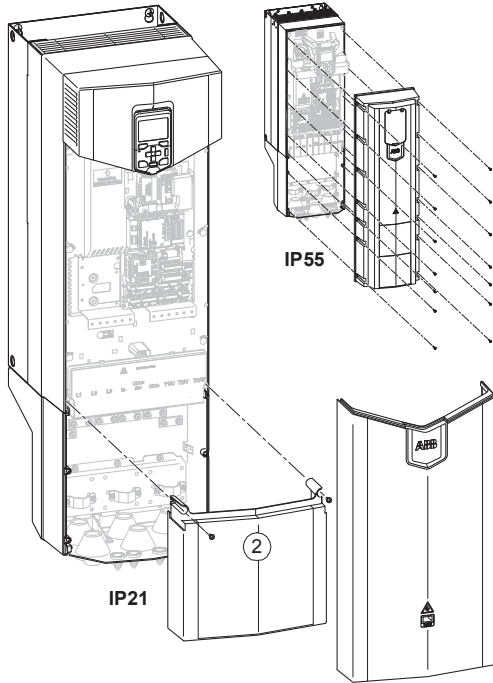
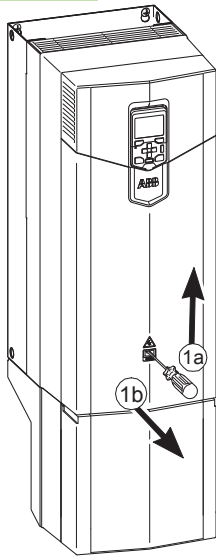

R6 ... R9

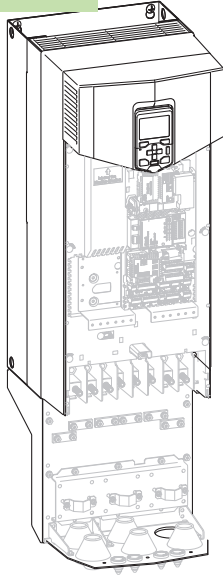

R8, R9

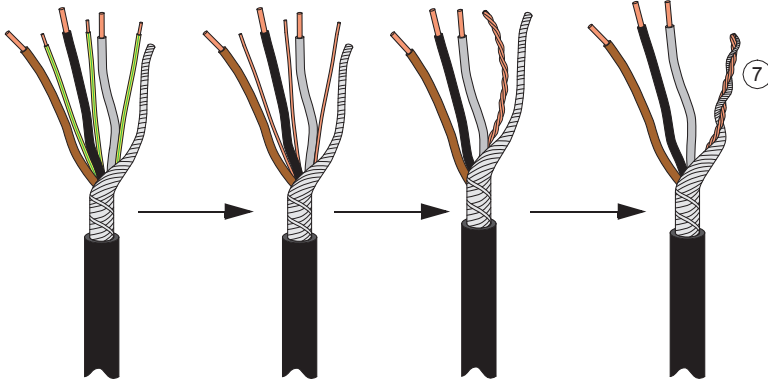
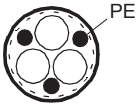
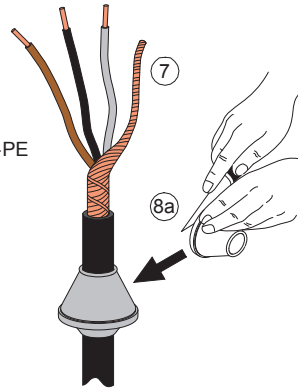
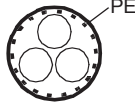
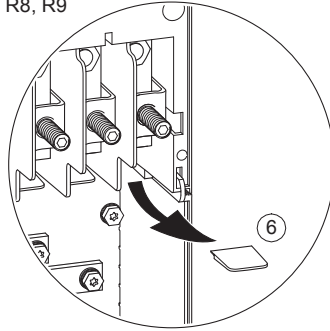

R6 ... R9

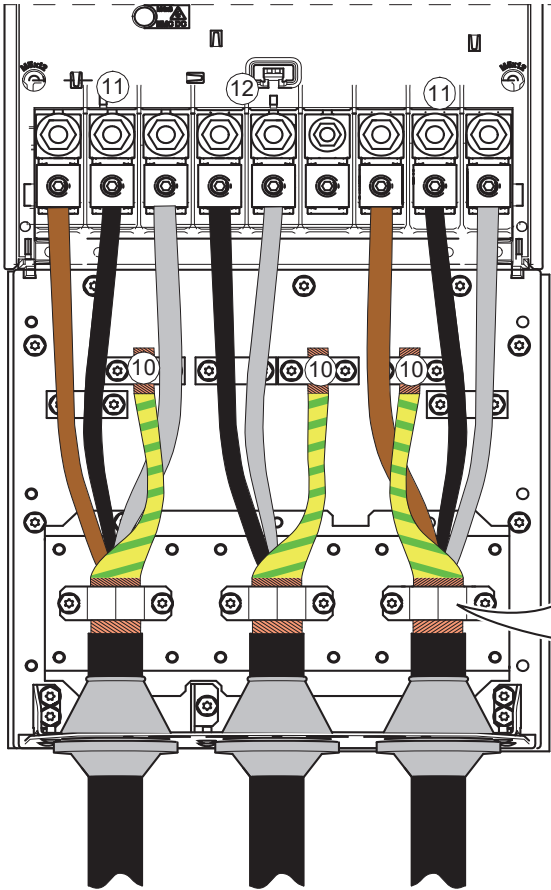

- R6: M5×25 Torx T20;  
M4×20 Torx T20
- R7: M5×35 Torx T20
- R8,R9: M5×25 Torx T20
- 2 N·m

Frame	L1, L2, L3, T1/U, T2/V, T3/W		R-, R+/UDC+, UDC-		⏏
	T (Wire screw)		T (Wire screw)		
	M...	N·m	M...	N·m	
R6	M10	30	M8	20	9.8
R7	M10	40	M10	30	9.8
R8	M10	40	M10	40	9.8
R9	M12	70	M12	70	9.8



R6 ... R9

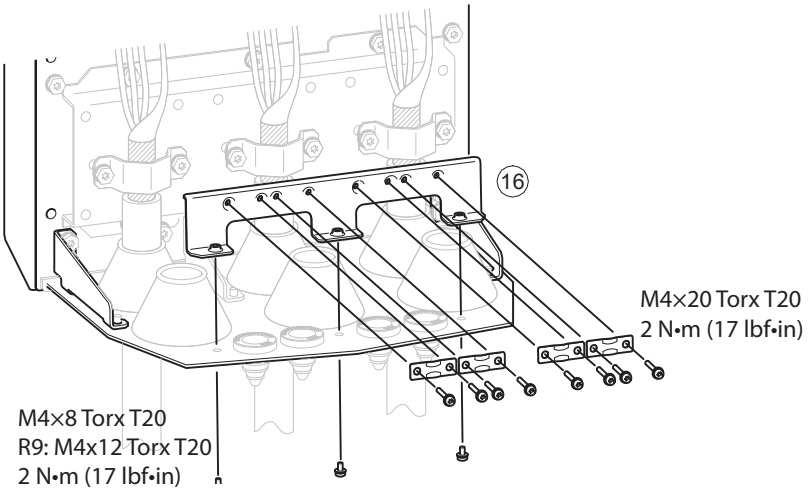
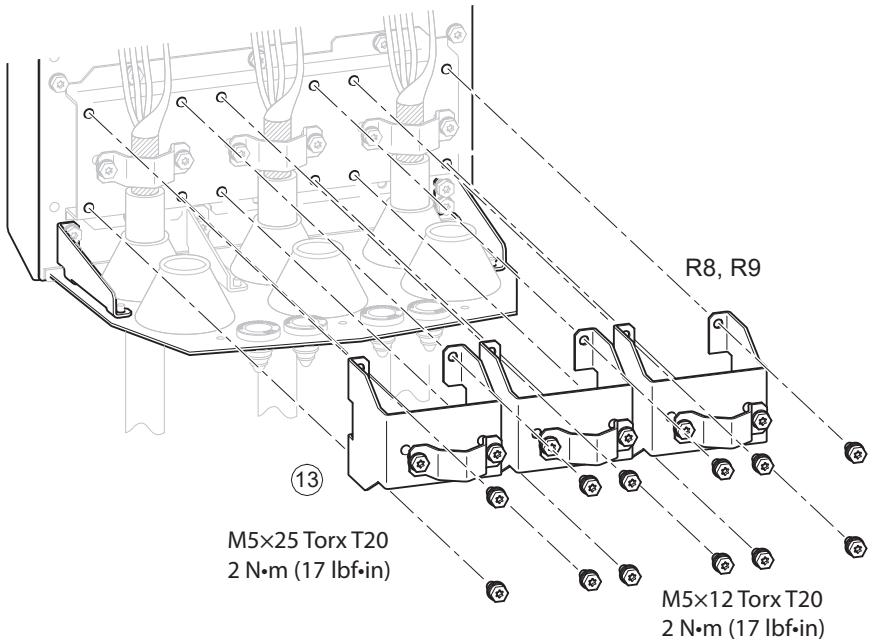

## Connecting the control cables

See section [Control units of the drive \(page 149\)](#) for the default I/O connections of the Factory macro of ACS880 primary control program. For other macros and control programs, see the firmware manual.

### ■ Connection process

This drawing shows an example connection of control cables.

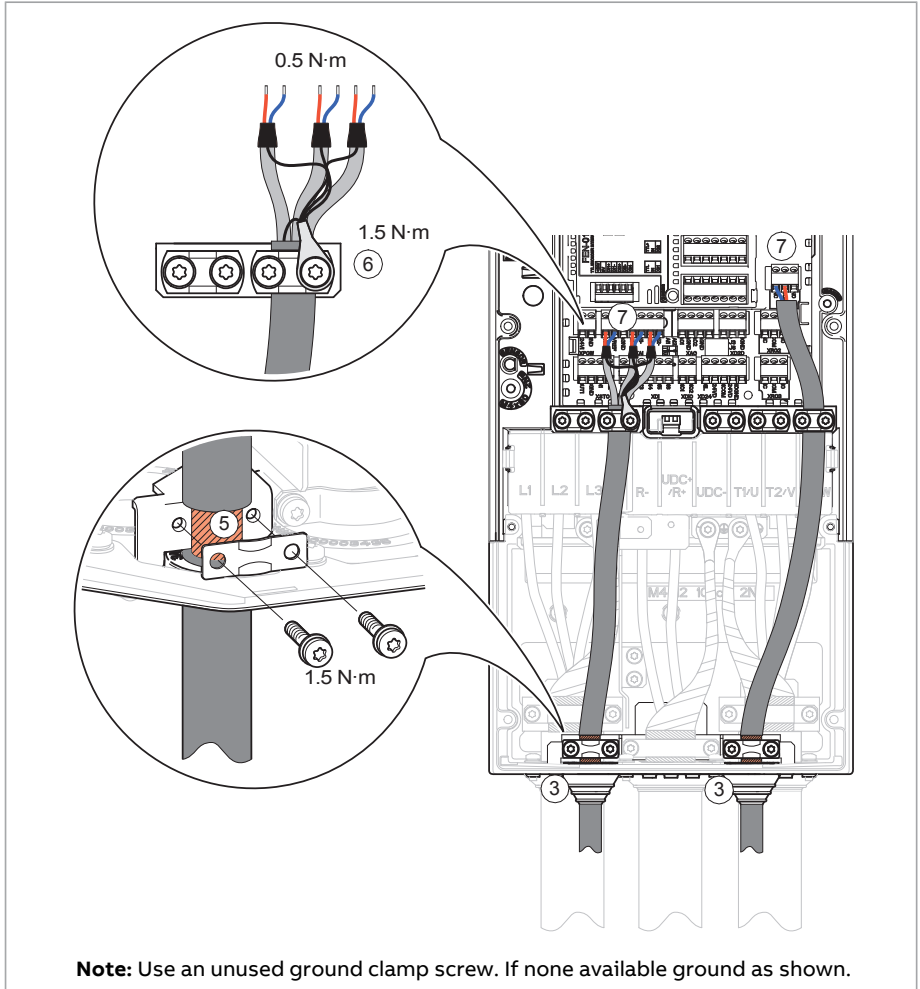



**WARNING!**

Obey the safety instructions of the drive. If you ignore them, injury or death, or damage to the equipment can occur.

---

1. Repeat the steps described in [Electrical safety precautions](#) (page 18).
2. Remove the front cover(s). See section [Connecting the power cables](#) (page 99).
3. Cut adequate holes into the rubber grommets and slide the grommets onto the cables. Slide the cables through the holes of the bottom plate and attach the grommets to the holes.
4. Route the cables as shown below.
5. Ground the outer shields of all control cables 360 degrees at a grounding clamp in the cable entry box. Tighten the clamp to 1.5 N·m (13 lbf-in). Keep the shields continuous as close to the terminals of the control unit as possible. Secure the cables mechanically at the clamps below the control unit. [Frames R1 to R3](#): Ground also the pair-cable shields and grounding wires at the cable entry box grounding clamp.
6. [Frames R4 to R9](#): Ground the pair-cable shields and all grounding wires to the clamp below the control unit.
7. Connect the conductors to the appropriate terminals of the control unit and tighten to 0.5 N·m (5 lbf-in).

**Note:**

- Leave the other ends of the control cable shields unconnected or ground them indirectly via a high-frequency capacitor with a few nanofarads, eg, 3.3 nF / 630 V. The shield can also be grounded directly at both ends if they are in the same ground line with no significant voltage drop between the end points.
- Keep any signal wire pairs twisted as close to the terminals as possible. Twisting the wire with its return wire reduces disturbances caused by inductive coupling.





## Connecting a PC



### WARNING!

Do not connect the PC directly to the control panel connector of the control unit as this can cause damage.

A PC (with, for example, the Drive composer PC tool) can be connected as follows:

1. Connect a ACS-AP-... or ACH-AP-... control panel to the unit either
  - by inserting the control panel into the panel holder or platform, or
  - by using an Ethernet (eg, Cat 5e) networking cable.
2. Remove the USB connector cover on the front of the control panel.
3. Connect an USB cable (Type A to Type Mini-B) between the USB connector on the control panel (3a) and a free USB port on the PC (3b).
4. The panel will display an indication whenever the connection is active.
5. See the documentation of the PC tool for setup instructions.

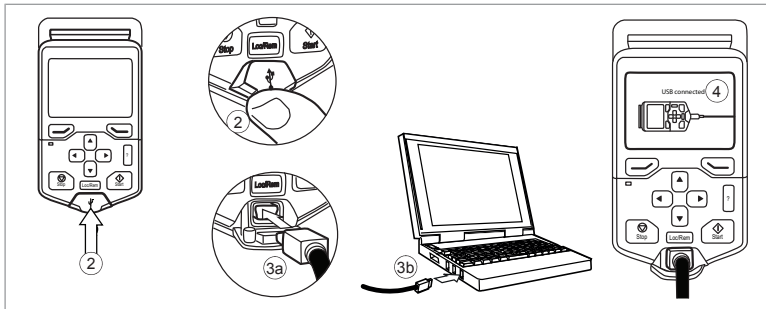

## Panel bus (control of several units from one control panel)

One control panel (or PC) can be used to control several drives (or inverter units, supply units etc.) by constructing a panel bus. This is done by daisy-chaining the panel connections of the drives. Some drives have the necessary (twin) panel connectors in the control panel holder; those that do not require the installation of an FDPI-02 module (available separately). For further information, see the hardware description and [FDPI-02 diagnostics and panel interface user's manual \(3AUA0000113618 \[English\]\)](#).

The maximum allowed length of the cable chain is 100 m (328 ft).

1. Connect the panel to one drive using an Ethernet (for example Cat 5e) cable.
  - Use Menu - Settings - Edit texts - Drive to give a descriptive name to the drive
  - Use parameter 49.01\* to assign the drive with a unique node ID number
  - Set other parameters in group 49\* if necessary



- Use parameter 49.06\* to validate any changes.  
\*The parameter group is 149 with supply (line-side), brake or DC/DC converter units.

Repeat the above for each drive.

2. With the panel connected to one unit, link the units using Ethernet cables.
3. Switch on the bus termination on the drive that is farthest from the control panel in the chain.
  - With drives that have the panel mounted on the front cover, move the terminating switch into the outer position.
  - With an FDPI-02 module, move termination switch S2 into the TERMINATED position.

Make sure that bus termination is off on all other drives.

4. On the control panel, switch on the panel bus functionality (Options - Select drive - Panel bus). The drive to be controlled can now be selected from the list under Options - Select drive.

If a PC is connected to the control panel, the drives on the panel bus are automatically displayed in the Drive composer tool.

**With twin connectors in the control panel holder:**

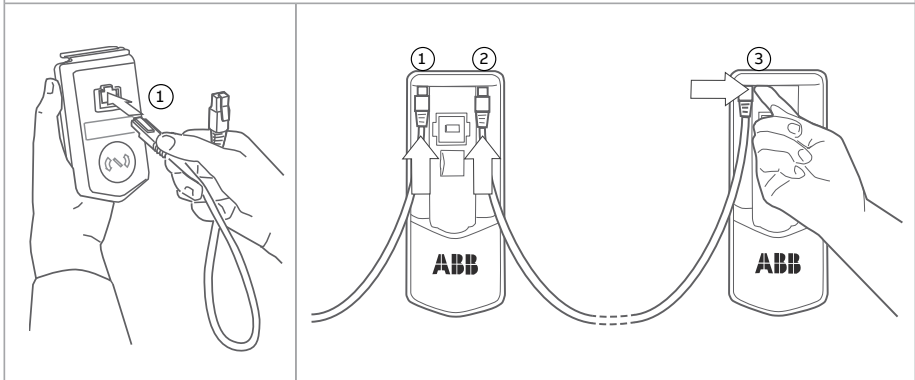

With FDPI-02 modules:

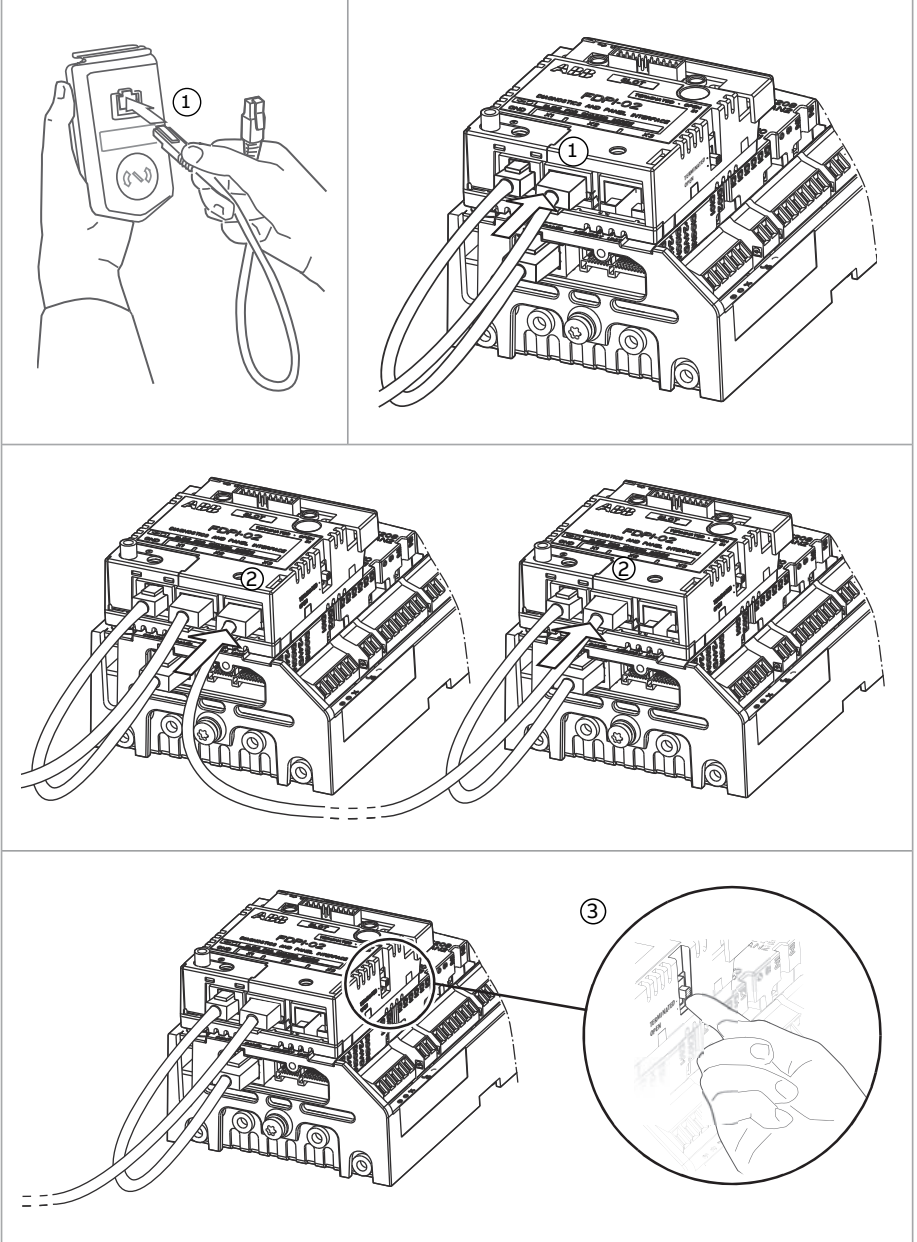

**ACS880-01 IP55 (UL Type 12):**

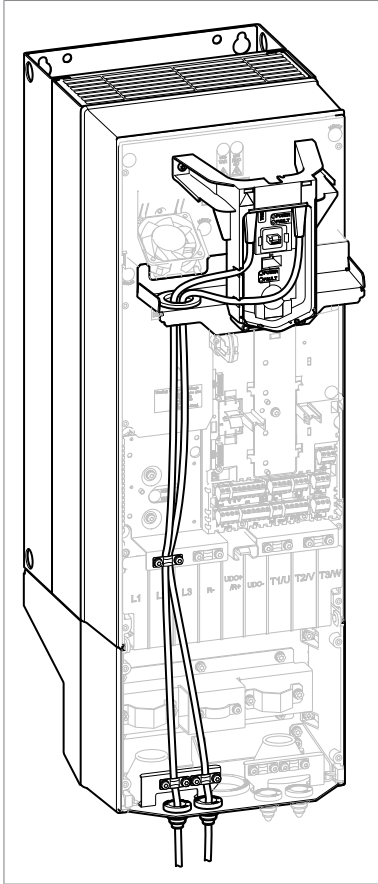

### Installing option modules

In frames R1 and R2, 90° connector cannot be used in Slot 1. In other frames, there is 50...55 mm free space for the connector and its cable available on Slots 1, 2 and 3.

For frames R1...R3: Pull the control panel mounting platform upwards to gain access to the optional module slots.



**WARNING!**

Obey the safety instructions of the drive. If you ignore them, injury or death, or damage to the equipment can occur.

Pay attention to the free space required by the cabling or terminals coming to the option modules.

1. Repeat the steps described in *Electrical safety precautions* (page 18).

2. Pull out the lock (a).

**Note:** The location of the lock depends on the module type.

3. Install the module to a free option module slot on the control unit.

4. Push in the lock (a).

5. Tighten the grounding screw (b) to a torque of 0.8 N·m (7 lbf·in).

**Note:** The screw tightens the connections and grounds the module. It is essential for fulfilling the EMC requirements and for proper operation of the module.



**WARNING!**

Do not use excessive force, or leave the screw too loose. Over-tightening can damage the screw or module. A loose screw can cause an operation failure.

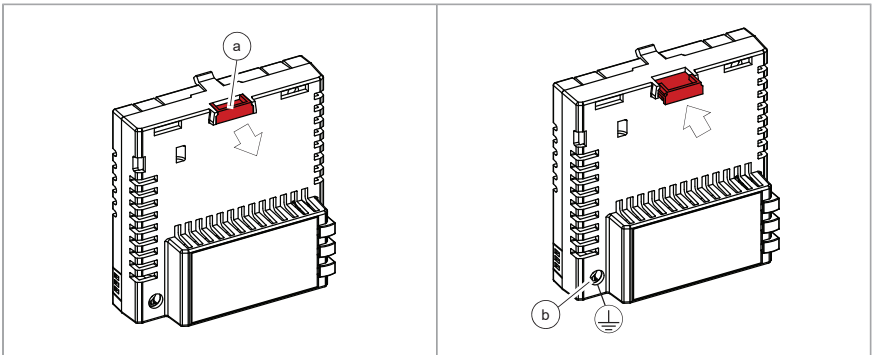

6. Connect the wiring to the module. Obey the instructions given in the documentation of the module.

### ■ Fieldbus cabling

1. Install the additional grounding shelf.

2. Ground the outer shields of the cables 360 degrees at a grounding clamp.

3. Knock out holes in the cable entry box cover for the cables to be installed. Install the cable entry box cover.

4. Plug the connector to the fieldbus module.

**R1...R3**

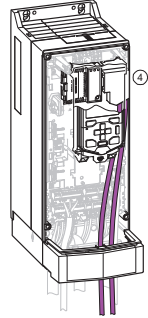
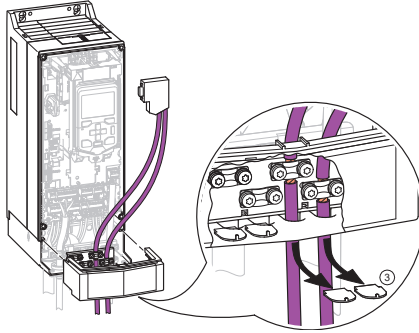
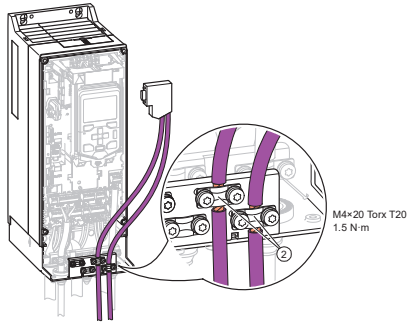
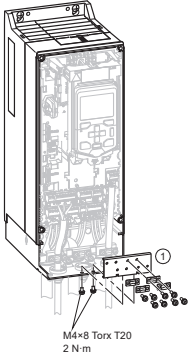

**R4, R5**

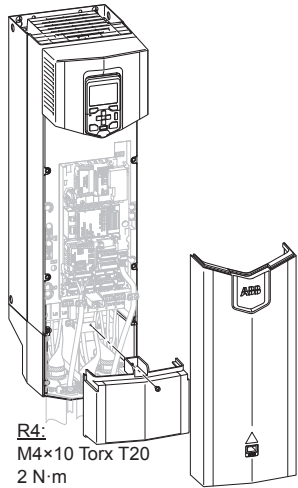
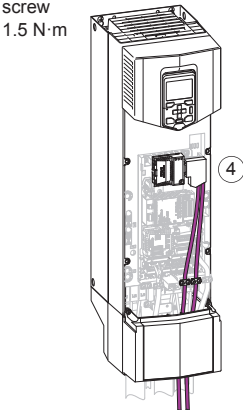
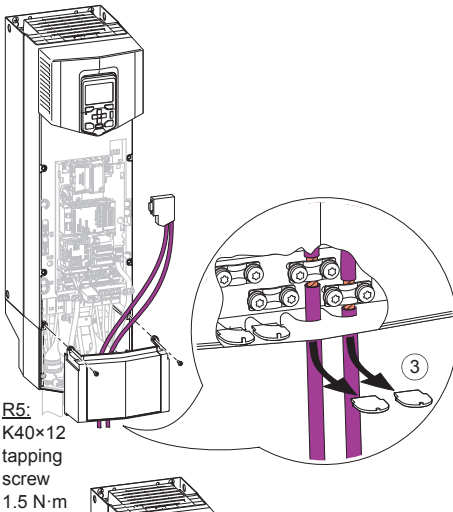
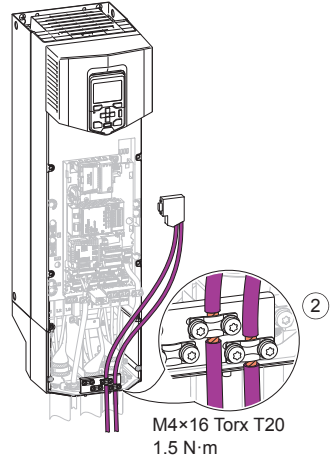
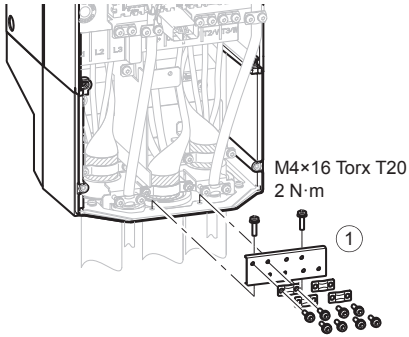

R6...R9

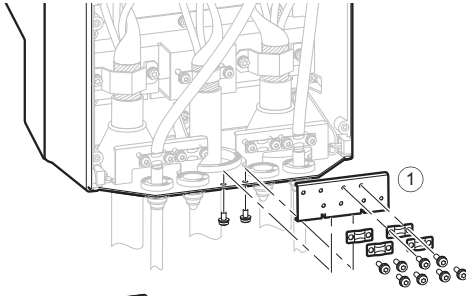

M4×8 Torx T20  
2 N·m

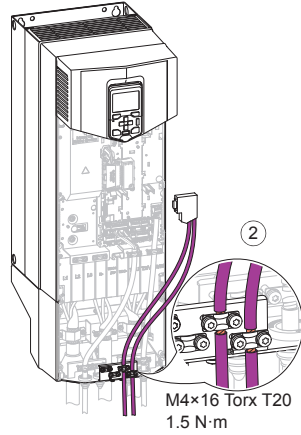

M4×16 Torx T20  
1.5 N·m

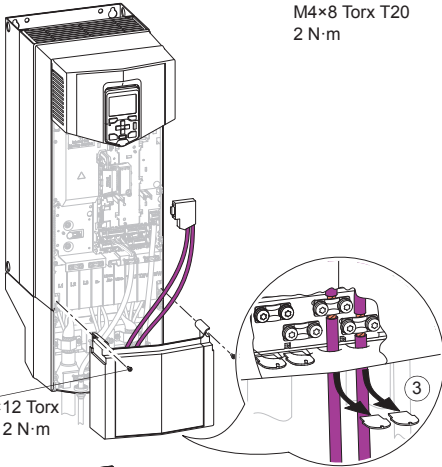

M4×12 Torx  
T20 2 N·m

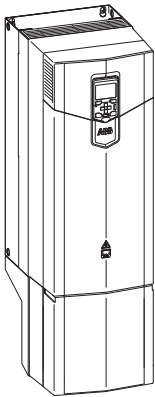
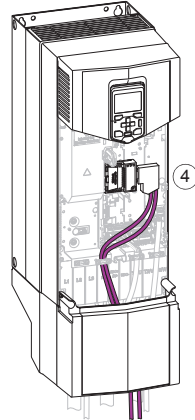



## ■ Installing FSO-xx safety functions modules

The safety functions module can be mounted onto Slot 2 on the control unit or, in frames R7...R9, also next to the control unit.

### Installation procedure

---

**WARNING!**

Obey the safety instructions of the drive. If you ignore them, injury or death, or damage to the equipment can occur.

---

1. Repeat the steps described in [Electrical safety precautions](#) (page 18).
2. Remove the front cover. See section [Connecting the power cables](#) (page 99).
3. Insert the module carefully into its position on the control unit or on its place next to the control unit.
4. Attach the module with four screws. Note: The grounding screw (a) is essential for fulfilling the EMC requirements and for proper operation of the module.
5. Tighten the grounding screw of the electronics to 0.8 N·m.
6. Connect the data communication cable to slot X110 on the module and to connector X12 on the drive control unit.
7. Connect the Safe torque off wires to connector X111 on the module and to connector XSTO on the drive module control unit.
8. Connect the external +24 V power supply cable to connector X112
9. Connect the other wires as shown in [FSO-12 safety functions module user's manual \(3AXD50000015612 \[English\]\)](#) or in [FSO-21 safety functions module user's manual \(3AXD50000015614 \[English\]\)](#).



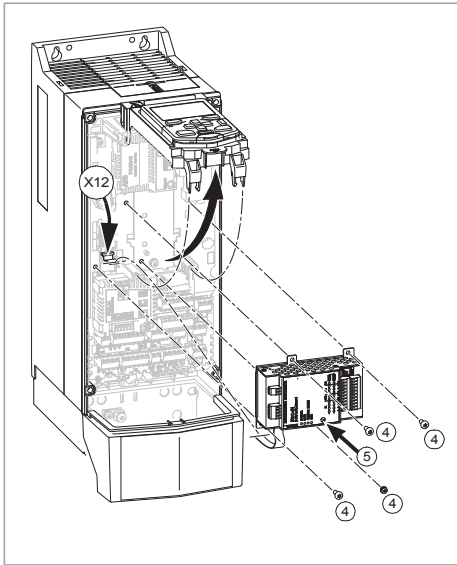

Installation on Slot 2. For frames R1...R3: Pull the control panel mounting platform upwards to gain access to the optional module slots.

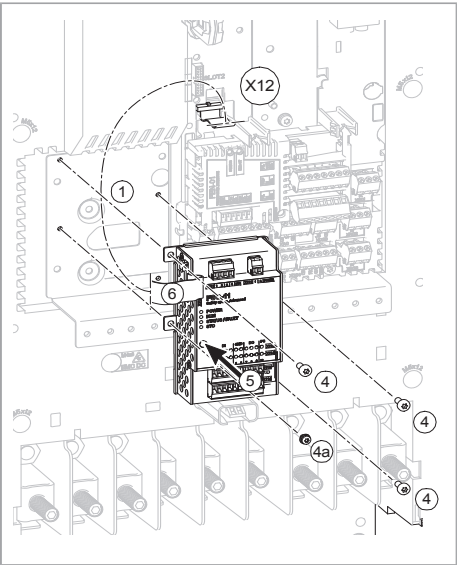

Installation next to the control unit (possible for frames R7...R9)



# 7

## Electrical installation – North America (NEC)

---

### Contents of this chapter

This chapter gives instructions on wiring the drive.

### Safety

---



#### **WARNING!**

If you are not a qualified electrical professional, do not do installation or maintenance work. Obey the safety instructions of the drive. If you ignore them, injury or death, or damage to the equipment can occur.

---

### Required tools

To do the electrical installation, you need these tools:

- wire stripper
- screwdriver set (Torx, flat and/or Phillips, as appropriate)
- torque wrench.

### Measuring the insulation

See section [Measuring the insulation](#) (page 96).

---



## Grounding system compatibility check

See section Grounding system compatibility check (page 97).

### Connecting the power cables

#### ■ Connection diagram

**Note:** NEC installation can include separate insulated conductors inside a conduit, shielded VFD cable in conduit, or shielded VFD cable without conduit. The normal dashed symbol (c) in this diagram represents the shield of shielded VFD cable. The same solid symbol (b) represents conduit.

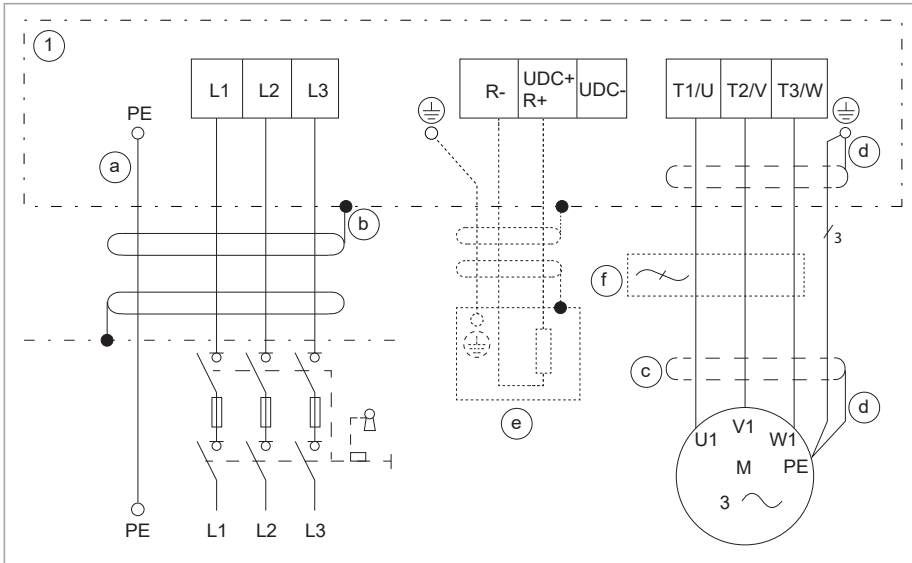

1	Drive
a	Insulated ground conductor in a conduit. Ground to drive's PE terminal and to the distribution panel ground bus. For a VFD cable installation see (d).
b	Conduit ground. Bond the conduit to the drive's conduit box and to the distribution panel enclosure. For a VFD cable installation see (c).
c	Shield of a VFD shielded cable. Ground the shield 360° under drive's grounding clamp then twist and connect under the drive's ground terminal. Ground also the shield 360° at the motor end then twist and connect under the motor's ground terminal. For a conduit installation see (b).
d	Symmetrically constructed grounding conductors inside a VFD shielded cable. Twist together and ground under drive's ground terminal and under the motor's ground terminal. For a conduit installation see (a).

e	External brake resistor connection (if used). For a conduit installation: See a and b. For a VFD cable installation: See c and d. In addition, cut the third phase conductor which is not needed for the brake resistor connection. See chapter <i>Resistor braking</i> (page 279).
f	If necessary, install an external filter (du/dt, common mode, or sine filter). Filters are available from ABB.

**Note:** Do not use an asymmetrically constructed motor cable for motors above 30 kW. Connecting its fourth conductor at the motor end increases bearing currents and causes extra wear.

All openings in the drive enclosure must be closed with UL listed devices having the same Type rating as the drive Type.



### ■ Connection procedure for frames R1 to R3

Use symmetrical shielded VFD cable for the motor cabling.

1. Undo the mounting screws at the sides of the front cover.
2. Remove the cover by sliding it forward.
3. Attach the residual voltage warning sticker in the local language to the control panel mounting platform.
4. Remove the rubber grommets from the entry plate for the cables to be connected.
5. Attach the cable conduit to the drive conduit plate, and to the motor or source of power distribution. Make sure both ends of the conduit is correctly bonded both ends of the conduit. Ensure conductivity of the conduit. Slide the VFD shielded cable or discrete conductors through the conduit and strip the cable ends.
6. Cut the cables to suitable length (note the extra length of the grounding conductors). If you use a symmetrically shielded VFD cable, twist the grounding wires together with the cable shield and connect them to the grounding terminals. Ground the shield 360 degrees at the grounding clamp. If you use discrete conductors connect the insulated ground conductor to the ground terminal.

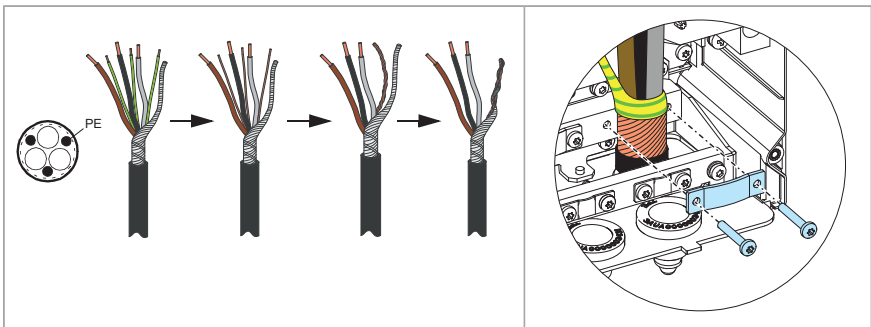
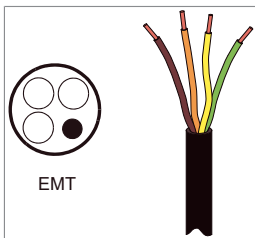

7. Connect the phase conductors of the input and motor cables. Tighten the screws.

8. If brake chopper is in use: Connect the brake resistor conductors to the R+ and R- terminals.
9. Install the control cable grounding shelf in the cable entry box.
10. Connect the motor cable at the motor end.

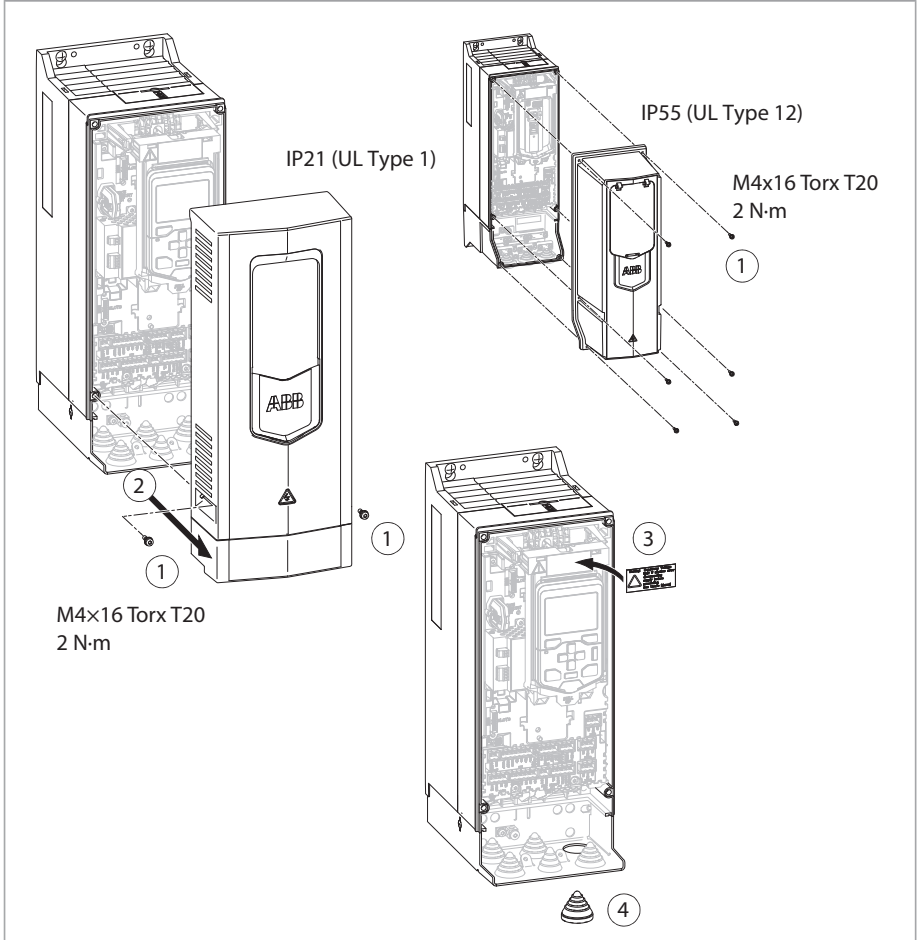

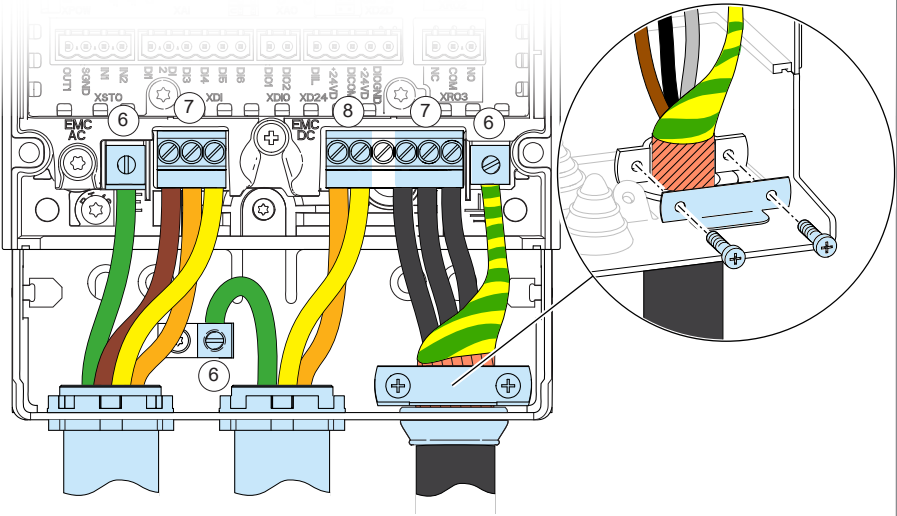
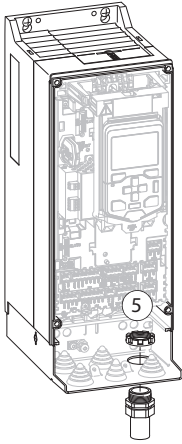

	L1, L2, L3, T1/U, T2/V, T3/W, r-, R+/UDC+, UDC-	Ground	Clamp
	lbf-ft	lbf-ft	lbf-in
R1	0.4	1.3	13.3
R2	0.4	1.3	13.3
R3	1.3	1.3	17



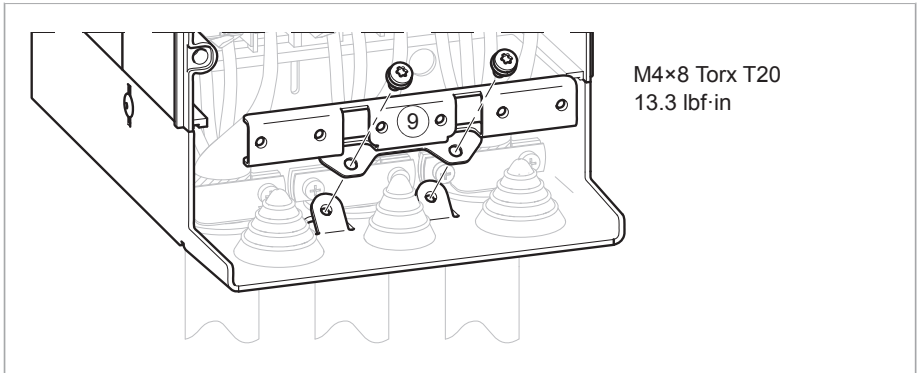

### ■ Connection procedure for frames R4 and R5

In this connection procedure, the cables are connected to the power cable connectors.

Use symmetrical shielded VFD cable for the motor cabling.

1. Remove the front cover. **UL Type 1 units:** Release the retaining clip with a screwdriver (a) and lift the cover from the bottom outwards (b). Remove the cable entry box cover by undoing the mounting screw.
2. Attach the residual voltage warning sticker in the local language next to the control board top.
3. Remove the shroud on the power cable terminals by releasing the clips and lifting the shroud up from the sides with a screwdriver (a). Knock out holes in the shroud for the cables to be installed (b). Remove the EMC shroud that separates the input and output cabling if needed for easier installation (see drawing of point 9).
4. Attach the cable conduit to the drive conduit plate, and to the motor or source of power distribution. Make sure both ends of the conduit is correctly bonded both ends of the conduit. Ensure conductivity of the conduit. Slide the VFD shielded cable or discrete conductors through the conduit and strip the cable ends.
5. Cut the cables to suitable length (note the extra length of the grounding conductors). If you use a symmetrically shielded VFD cable, twist the grounding wires together with the cable shield and connect them to the grounding terminals. Ground the shield 360 degrees at the clamp. If you use discrete conductors connect the insulated ground conductor to the grounding terminal.



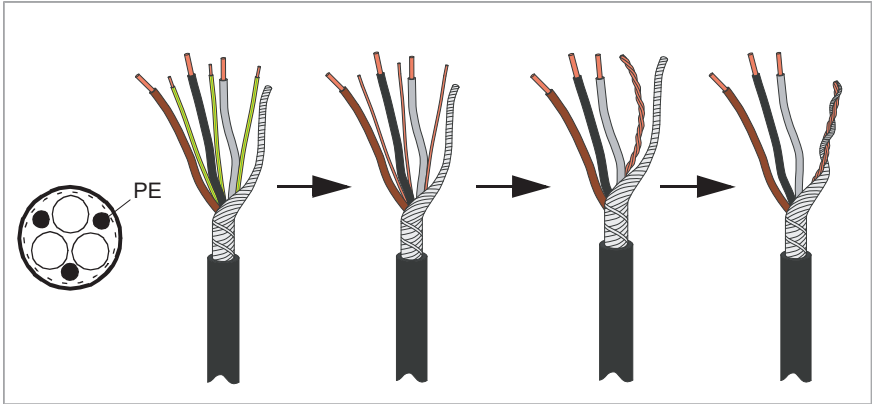
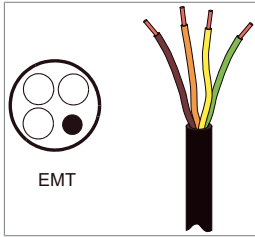

6. Connect the conductors of the input and motor cables. Tighten the screws.
7. Install the EMC shroud separating the input and output cabling if not installed yet.
8. If brake chopper is in use: Connect the conductors of the brake resistor conductors to the R+ and R- terminals.
9. Reinstall the shroud on the power cable terminals.
10. Install the shroud.
11. Connect the motor cable at the motor end.



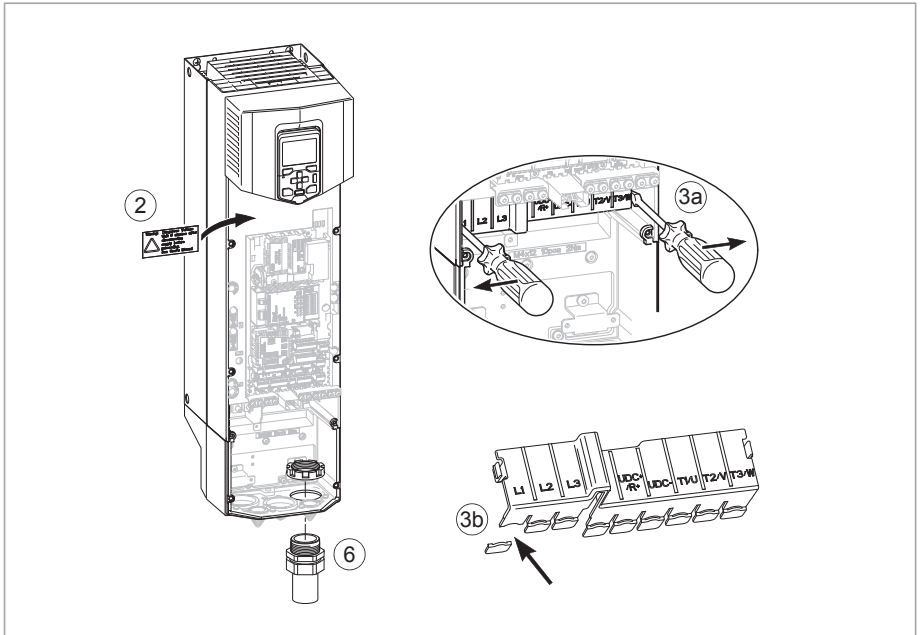

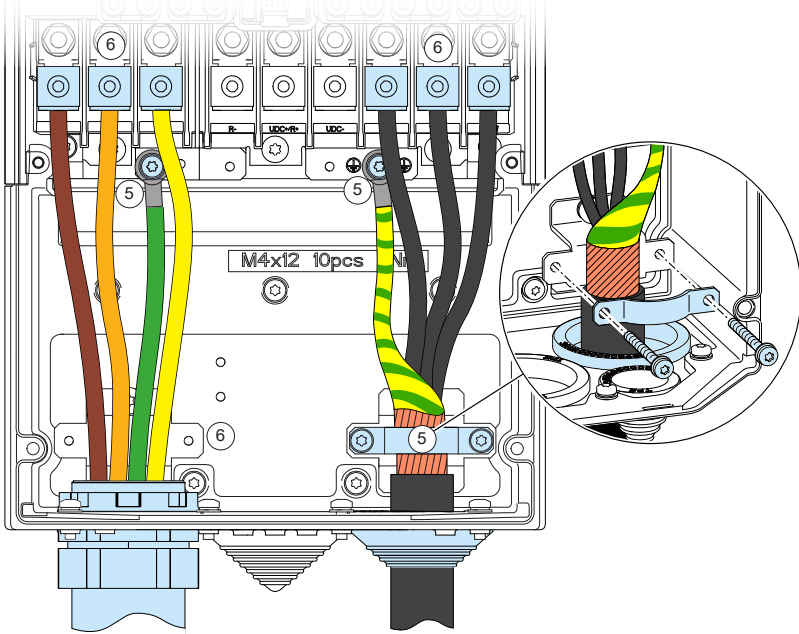

	<b>L1, L2, L3, T1/U, T2/V, T3W, R-, R+/UDC+, UDC-</b>	<b>Ground</b>	<b>Clamp</b>
	<b>lbf-ft</b>	<b>lbf-ft</b>	<b>lbf-in</b>
R4	2.4	2.1	10.6
R5	11	2.1	10.6

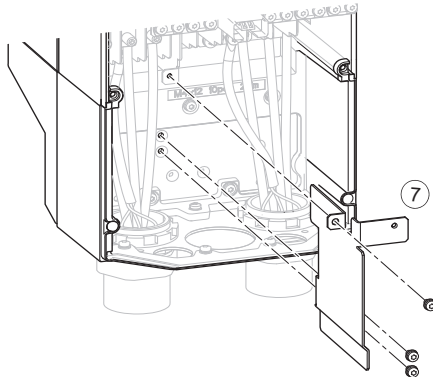

**R4:** M4×8 Torx T20 (2 pcs), M4×10 Torx T20 (1 pcs), 1.5 lbf-ft  
**R5:** M4×8 Torx T20, 1.5 lbf-ft

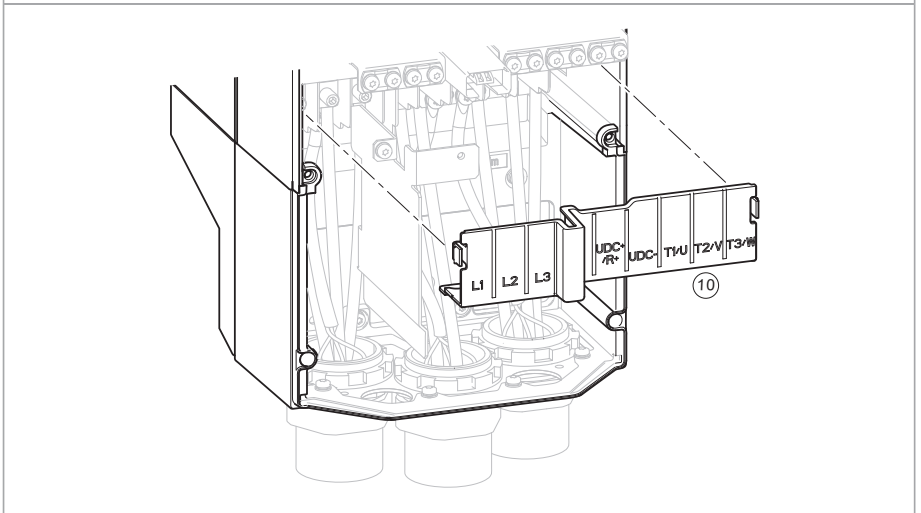
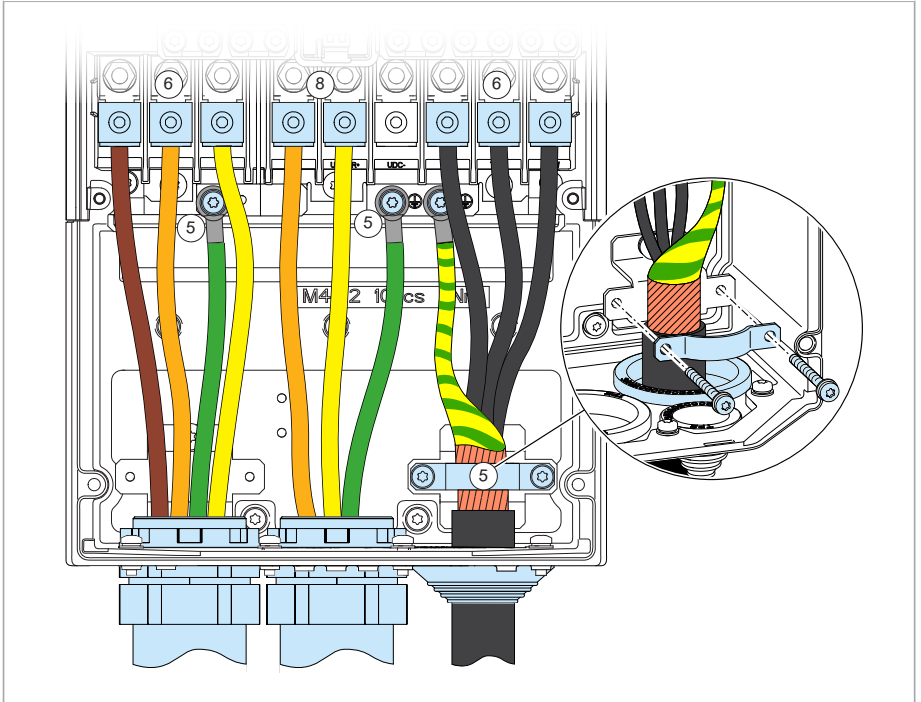

### ■ Connection procedure for frames R6 to R9

In this connection procedure, the cables are connected to the power cable connectors.

Use symmetrical shielded VFD cable for the motor cabling.

1. Remove the front cover: UL Type 1 drives: Release the retaining clip with a screwdriver (a) and pull the cover by the bottom outwards (b).
2. UL Type 1 drives: Remove the cable entry box cover by undoing the mounting screws.
3. Attach the residual voltage warning sticker in the local language next to the control board top.
4. Remove the side plates of the cable entry box.
5. Remove the shroud on the power cable terminals by releasing the clips on the sides with a screwdriver and lifting (a). If parallel cables are installed, knock out holes for the cables (b).
6. Knock out the shrouds on the power cable terminals for the cables to be installed.
7. Attach the cable conduit to the drive conduit plate, and to the motor or source of power distribution. Make sure both ends of the conduit is correctly bonded both ends of the conduit. Ensure conductivity of the conduit. Ensure conductivity of the conduit. Slide the VFD shielded cable or discrete conductors through the conduit and strip the cable ends.
8. Cut the cables to suitable length (note the extra length of the grounding conductors). If you use a symmetrically shielded VFD cable, twist the grounding wires together with the cable shield and connect them to the grounding terminals. Ground the shield 360 degrees at the clamp. If you use discrete conductors connect the insulated ground conductor to the grounding terminal.

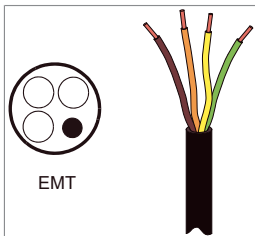

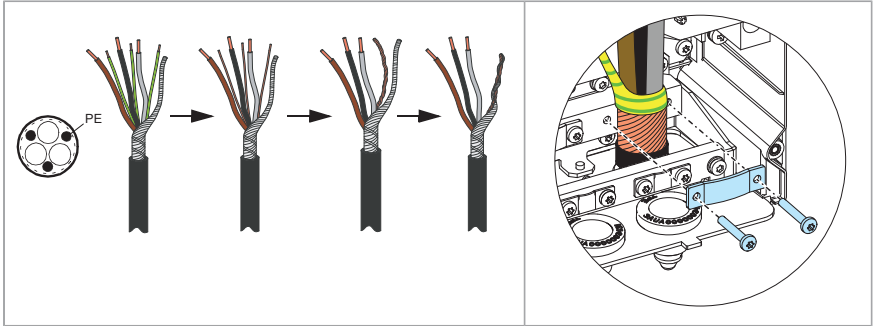

9. Connect the conductors of the input and motor cables. Tighten the screws.
10. Drives with option +D150: Connect the conductors of the brake resistor conductors to the R+ and R- terminals.
11. Reinstall the shroud on the power terminals.
12. Reinstall the side plates of the cable entry box.

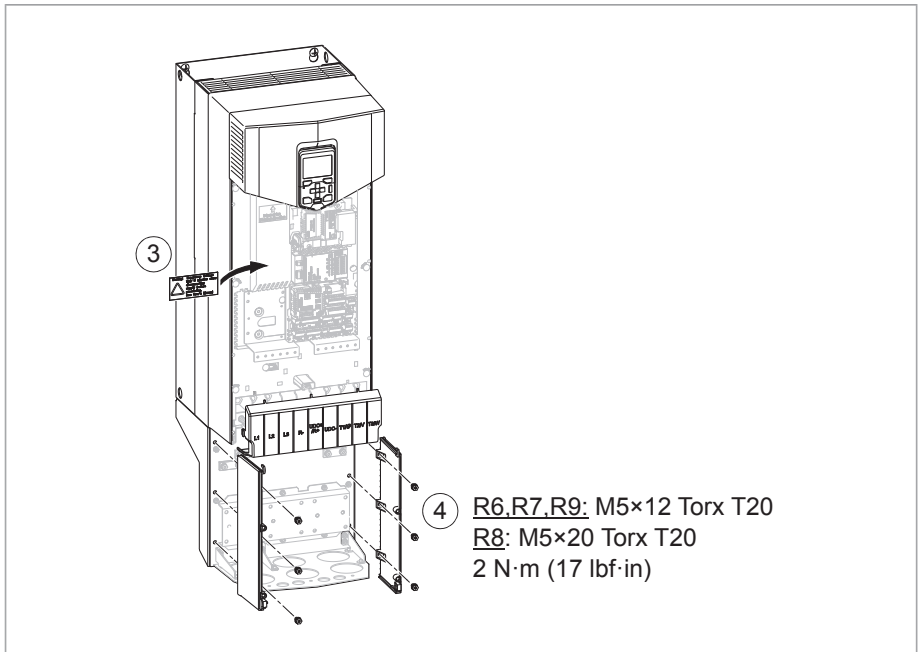

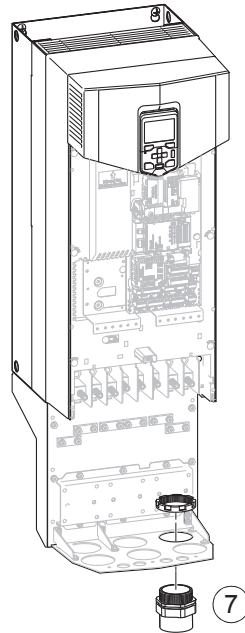
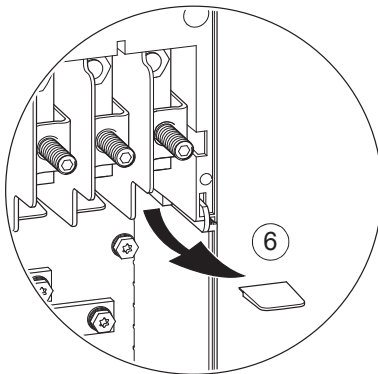
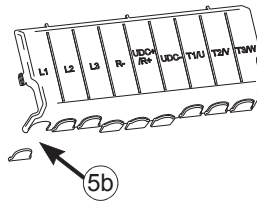
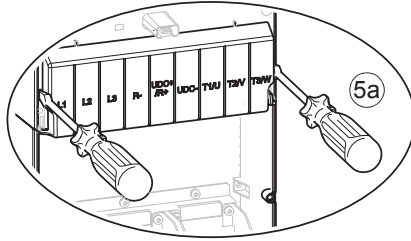



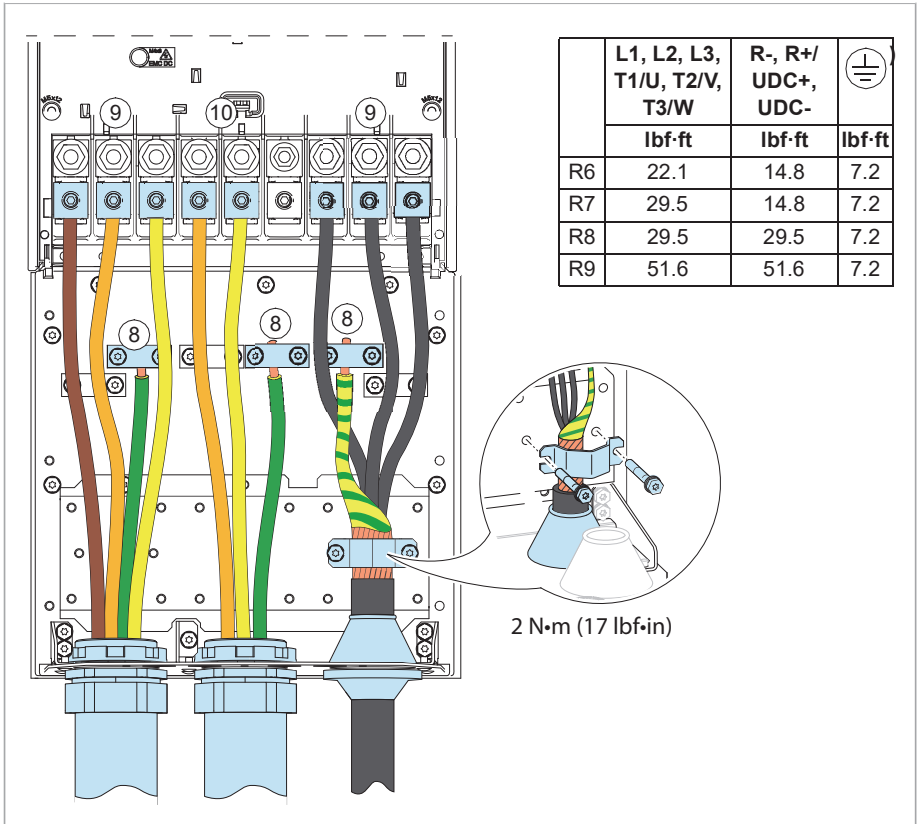

## Connecting the control cables

See section [Control units of the drive \(page 149\)](#) for the default I/O connections of the Factory macro of ACS880 primary control program. For other macros and control programs, see the firmware manual.

### ■ Connection procedure

1. Stop the drive and do the steps in section [Electrical safety precautions \(page 18\)](#) before you start the work.
2. Attach the cable conduits to the drive conduit plate. Make sure the conduit is correctly bonded at both ends and that conductivity is consistent throughout the conduit. Slide the control cables through the conduit. Cut to suitable length (note the extra length of the grounding conductors) and strip the conductors.
3. Ground the outer shields of all control cables 360 degrees at a grounding clamp.



## 142 Electrical installation – North America (NEC)

4. Ground the pair-cable shields to the grounding clamp (in frames R4 and R5 below the control unit). Leave the other end of the shields unconnected or ground them indirectly via a high-frequency capacitor with a few nanofarads, eg, 3.3 nF / 630 V.
5. Connect the conductors to the appropriate terminals of the control unit.
6. Wire the optional modules if included in the delivery.
7. Reinstall the front cover.



Frames R1...R3

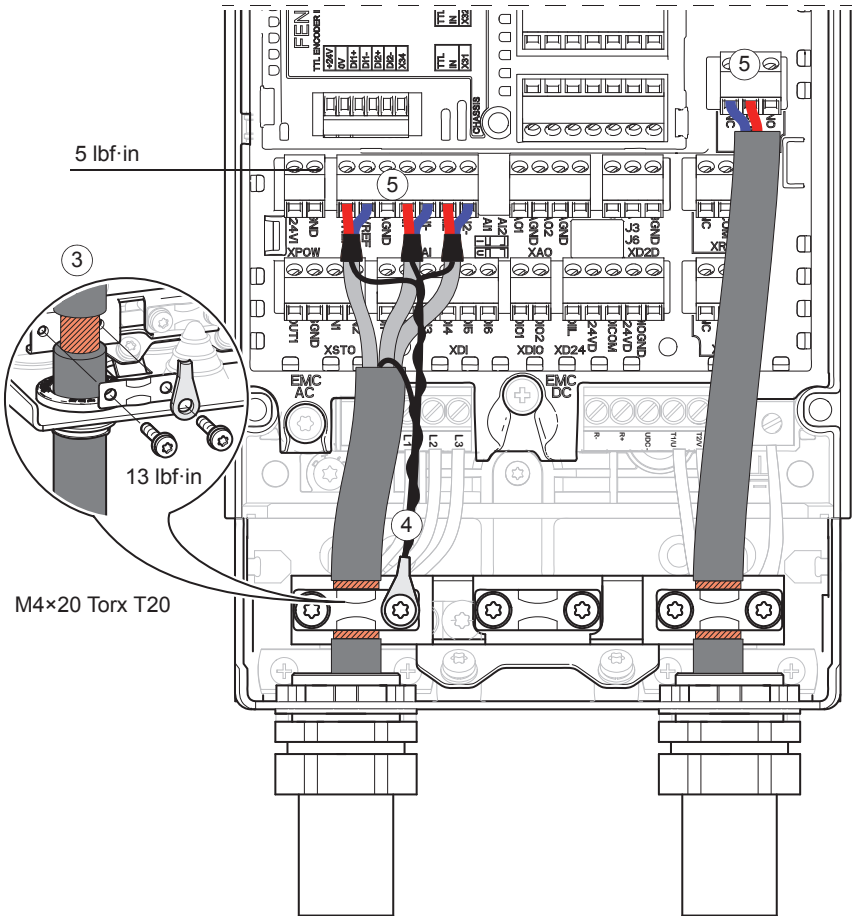

**Note:** Use an unused ground clamp screw. If none available ground as shown.



Frames R4 and R5

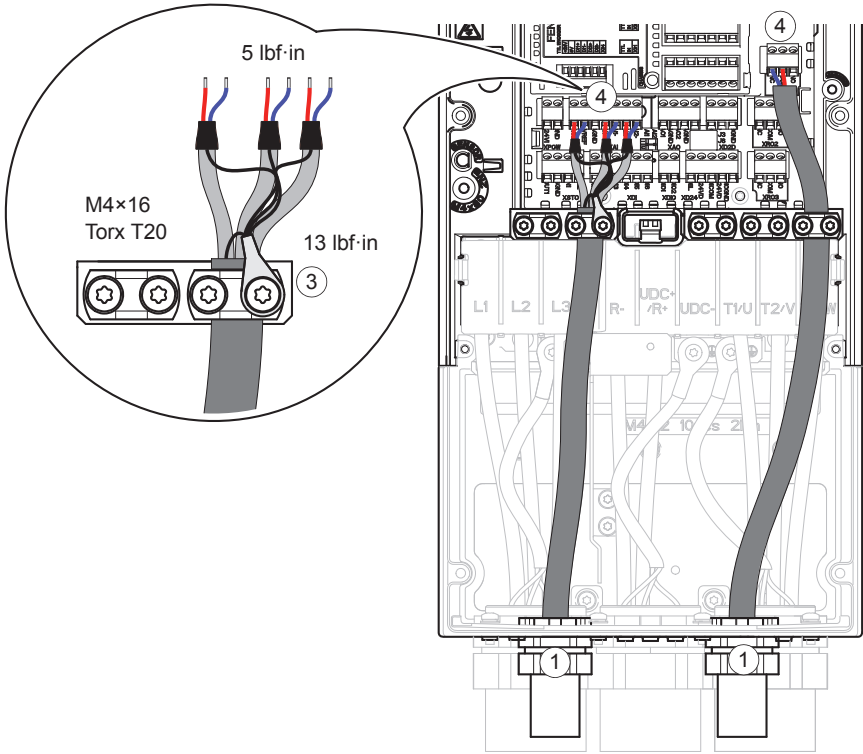

**Note:** Use an unused ground clamp screw. If none available ground as shown.



**Frames R6...R9**

Install the control cable grounding shelf.

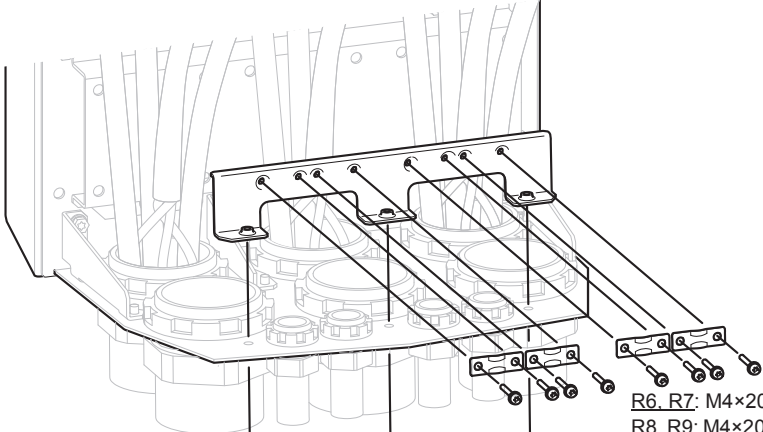

M4×8 Torx T20

R9: M4×12 Torx T20  
17 lbf·in

R6, R7: M4×20 Torx T20  
R8, R9: M4×20 Torx T20  
17 lbf·in



Frames R6...R9

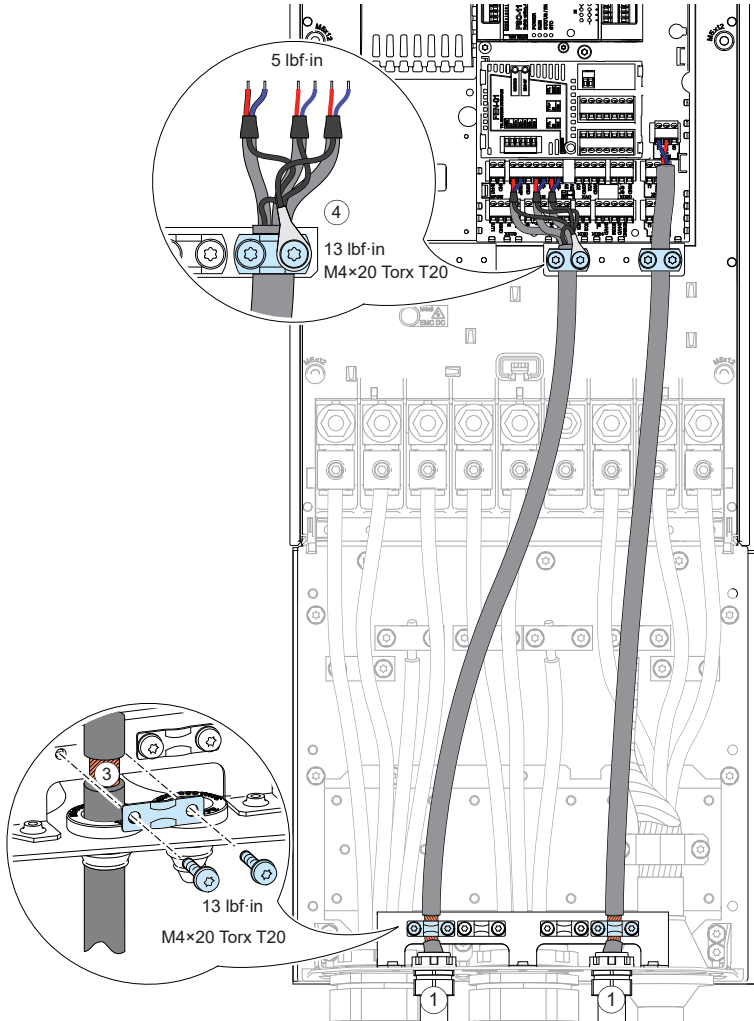

**Note:** Use an unused ground clamp screw. If none available ground as shown.

## Connecting a PC

See section [Connecting a PC](#) (page 117).

## **Panel bus (control of several units from one control panel)**

See section [Panel bus \(control of several units from one control panel\)](#) (page 117).

## **Installing option modules**

See section [Installing option modules](#) (page 120).









# Control units of the drive

---

## Contents of this chapter

This chapter

- describes the connections of the control unit(s) used in the drive,
- contains the specifications of the inputs and outputs of the control unit(s).

## ZCU-12 layout

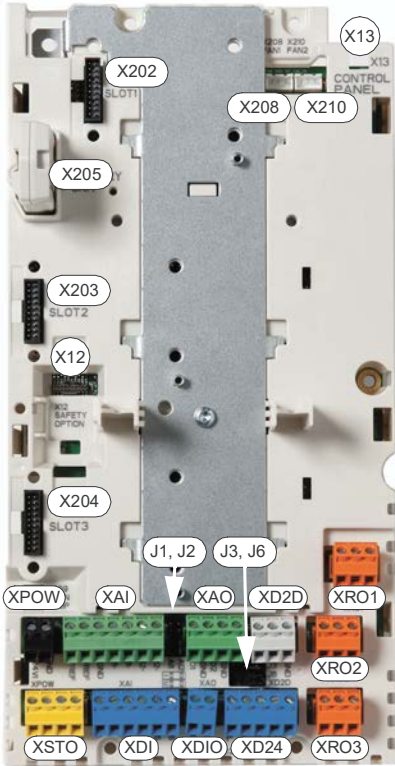

	Description
XAI	Analog inputs
XAO	Analog outputs
XDI	Digital inputs
XDIO	Digital input/outputs
XD24	Digital input interlock (DIIL) and +24 V output
XD2D	Drive-to-drive link
XPOW	External power input
XRO1	Relay output RO1
XRO2	Relay output RO2
XRO3	Relay output RO3
XSTO	Safe torque off connection
X12	Connection for FSO safety functions module
X13	Control panel connection
X202	Option slot 1
X203	Option slot 2
X204	Option slot 3
X205	Memory unit connection (memory unit inserted in the picture)
X208	Cooling fan 1 connection
X210	Cooling fan 2 connection
J1, J2	Voltage/Current selection jumpers (J1, J2) for analog inputs
J3	Drive-to-drive link termination switch (J3)
J6	Common digital input ground selection switch (J6)

## Default I/O diagram of the drive control unit (ZCU-1x)

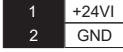
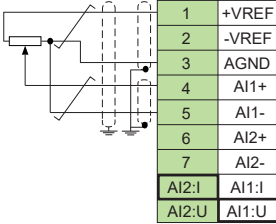
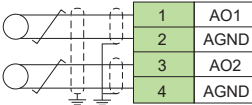
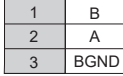
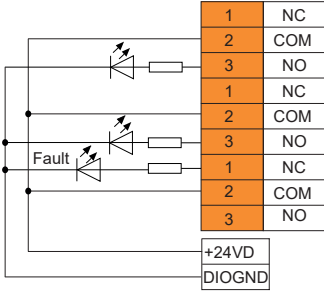
Connection	Term	Description
<b>XPOW</b> External power input		
	+24VI	24 V DC, 2 A min. (without optional modules)
	GND	
<b>J1, J2, XAI</b> Reference voltage and analog inputs		
	+VREF	11 V DC, $R_L$ 1...10 kohm
	-VREF	-11 V DC, $R_L$ 1...10 kohm
	AGND	Ground
	AI1+	<b>Speed reference</b>
	AI1-	0(2)...11 V, $R_{in} > 200$ kohm <sup>1)</sup> selected by switch AI1.
	AI2+	By default not in use.
	AI2-	0(4)...22 mA, $R_{in} = 100$ ohm <sup>2)</sup>
	AI1: I AI1: U	AI1/AI2 current/voltage selection
<b>XAO</b> Analog outputs		
	AO1	<b>Motor speed rpm</b>
	AGND	0...22 mA, $R_L < 500$ ohm
	AO2	<b>Motor current</b>
	AGND	0...22 mA, $R_L < 500$ ohm
<b>XD2D</b> Drive-to-drive link		
	B	Master/follower, drive-to-drive or embedded fieldbus connection <sup>3)</sup>
	A	
	BGND	
	<b>J3</b>	Drive-to-drive link termination <sup>3)</sup>
<b>XRO1, XRO2, XRO3</b> Relay outputs		
	NC	<b>Ready run</b>
	COM	250 V AC / 30 V DC
	NO	2 A
	NC	<b>Running</b>
	COM	250 V AC / 30 V DC
	NO	2 A
	NC	<b>Fault (-1)</b>
	COM	250 V AC / 30 V DC
	NO	2 A

152 Control units of the drive

Connection	Term	Description
<b>XD24</b> Auxiliary voltage output, digital interlock <sup>4)</sup>		
	1 DIIL	DIIL Run enable <sup>4)</sup>
	2 +24VD	+24VD +24 V DC 200 mA
	3 DICOM	DICOM Digital input ground
	4 +24VD	+24VD +24 V DC 200 mA <sup>5)</sup>
	5 DIOGND	DIOGND Digital input/output ground
<b>XDIO</b> Digital input/outputs		
	DIO1	Output: Ready run
	DIO2	Output: Running
	<b>J6</b>	Ground selection <sup>6)</sup>
<b>XDI</b> Digital inputs		
	DI1	Stop (0) / Start (1)
	DI2	Forward (0) / Reverse (1)
	DI3	Reset
	DI4	Acc/Dec time select <sup>7)</sup>
	DI5	Constant speed 1 (1 = On) <sup>8)</sup>
	DI6	By default, not in use.
<b>XSTO</b>	Safe torque off circuits must be closed for the drive to start. <sup>9)</sup>	
<b>X12</b>	Safety options connection	
<b>X13</b>	Control panel connection	
<b>X205</b>	Memory unit connection	

- 1) Current [0(4)...22 mA,  $R_{in} = 100 \text{ ohm}$ ] or voltage [0(2)...11 V,  $R_{in} > 200 \text{ kohm}$ ] input selected by switch AI1. Change of setting requires reboot of control unit.
- 2) Current [0(4)...22 mA,  $R_{in} = 100 \text{ ohm}$ ] or voltage [0(2)...11 V,  $R_{in} > 200 \text{ kohm}$ ] input selected by switch AI2. Change of setting requires reboot of control unit.
- 3) See section The XD2D connector (page 154)
- 4) See section DIIL input (page 154).  
Total load capacity of these outputs is 4.8 W (200 mA at 24 V) minus the power taken by DIO1 and DIO2.
- 5) Determines whether DICOM is separated from DIOGND (ie. common reference for digital inputs floats; in practice, selects whether the digital inputs are used in current sinking or sourcing mode). See also ZCU-1x ground isolation diagram (page 159). DICOM=DIOGND ON: DICOM connected to DIOGND. OFF: DICOM and DIOGND separate.
- 7) 0 = Acceleration/deceleration ramps defined by parameters 23.12/23.13 in use. 1 = Acceleration/deceleration ramps defined by parameters 23.14/23.15 in use.
- 8) Constant speed 1 is defined by parameter 22.26.
- 9) See chapter The Safe torque off function (page 293).

The wire size accepted by all screw terminals (for both stranded and solid wire) is 0.5 ... 2.5 mm<sup>2</sup> (24...12 AWG). The torque is 0.5 N·m (5 lbf·in).

## Additional information on the connections

### ■ External power supply for the control unit (XPOW)

The control unit is powered from a 24 V DC, 2 A supply through terminal block XPOW.

Using an external supply is recommended if

- the control unit needs to be kept operational during input power breaks, for example, because of continuous fieldbus communication
- immediate restart is needed after a power break (that is, no control unit power-up delay is allowed).

### ■ DI6 as a PTC sensor input

PTC sensors can be connected to this input for motor temperature measurement as follows. The sensor can alternatively be connected to a FEN encoder interface module. At the sensor end of the cable, leave the shields unconnected or ground them indirectly via a high-frequency capacitor with a few nanofarads, for example 3.3 nF / 630 V. The shield can also be grounded directly at both ends if they are in the same ground line with no significant voltage drop between the end points. See the firmware manual of the inverter unit for parameter settings.

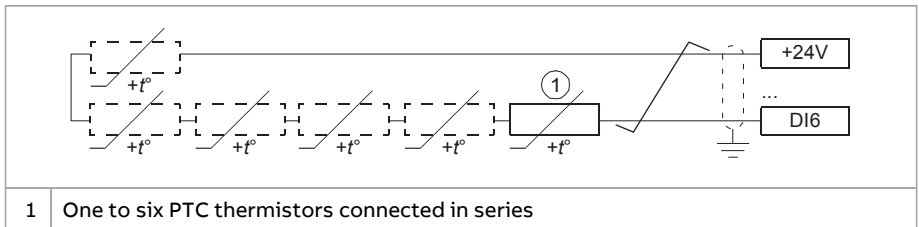

#### WARNING!

As the inputs pictured above are not insulated according to IEC 60664, the connection of the motor temperature sensor requires double or reinforced insulation between motor live parts and the sensor. Make sure that the voltage does not exceed the maximum allowed voltage over the PTC sensor.

### ■ AI1 or AI2 as a Pt100, Pt1000, PTC or KTY84 sensor input

Sensors for motor temperature measurement can be connected between an analog input and output, an example connection is shown below. (Alternatively, you can connect the KTY to an FIO-11 or FAIO-01 analog I/O extension module or a FEN encoder interface module.) At the sensor end of the cable, leave the shields unconnected or ground them indirectly via a high-frequency capacitor with a few nanofarads, for example 3.3 nF / 630 V. The shield can also be grounded directly

at both ends if they are in the same ground line with no significant voltage drop between the end points.

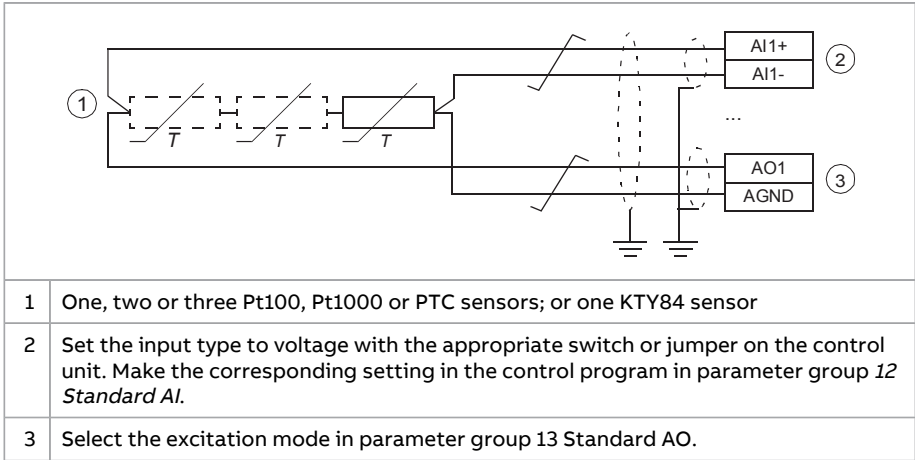

**⚡ WARNING!** As the inputs pictured above are not insulated according to IEC/EN 60664, the connection of the motor temperature sensor requires double or reinforced insulation between motor live parts and the sensor. Make sure that the current does not exceed the maximum allowed current through the Pt100/Pt1000 sensor.

■ **DIIL input**

The DIIL input is used for the connection of safety circuits. The input is parametrized to stop the unit when the input signal is lost.

**Note:** This input is NOT SIL or PL certified.

■ **The XD2D connector**

The XD2D connector provides an RS-485 connection that can be used for

- basic master/follower communication with one master drive and multiple followers,
- fieldbus control through the embedded fieldbus interface (EFB), or
- drive-to-drive (D2D) communication implemented by application programming.

See the firmware manual of the drive for the related parameter settings.

Enable bus termination on the units at the ends of the drive-to-drive link. Disable bus termination on the intermediate units.

Use shielded twisted-pair cable with a twisted pair for data and a wire or another pair for signal ground (nominal impedance 100 ... 165 ohm, for example Belden 9842) for the wiring. For best immunity, ABB recommends high quality cable. Keep the cable as short as possible. Avoid unnecessary loops and parallel runs near power cables such as motor cables.

The following diagram shows the wiring between control units.

### ZCU-12

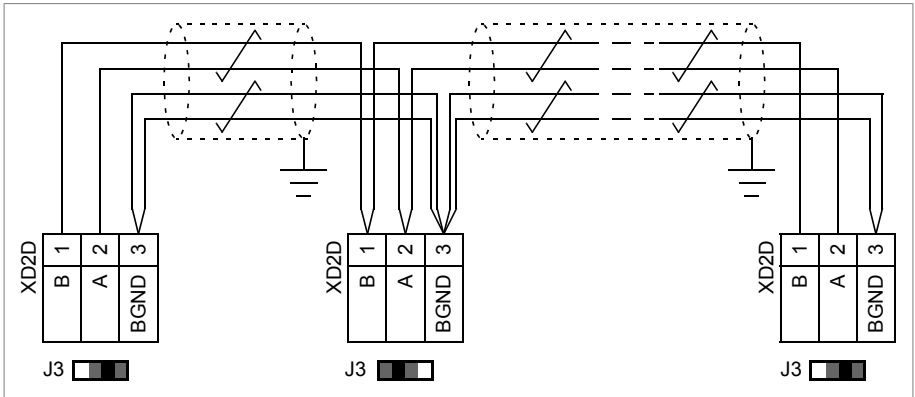

### ■ Safe torque off (XSTO)

See chapter [The Safe torque off function \(page 293\)](#).

**Note:** The XSTO input only acts as a true Safe torque off input on the inverter control unit. De-energizing the IN1 and/or IN2 terminals of other units (supply, DC/DC converter, or brake unit) will stop the unit but not constitute a true safety function.

### ■ FSO safety functions module connection (X12)

Refer to the applicable FSO module user's manual.

## Connector data

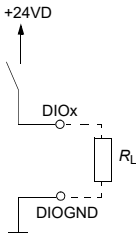
<p>Power supply (XPOW)</p>	<p>Connector pitch 5 mm, wire size 0.5 ... 2.5 mm<sup>2</sup> (22...12 AWG) 24 V (±10%) DC, 2 A External power input.</p>
<p>Relay outputs RO1...RO3 (XRO1...XRO3)</p>	<p>Connector pitch 5 mm, wire size 0.5 ... 2.5 mm<sup>2</sup> (22...12 AWG) 250 V AC / 30 V DC, 2 A Protected by varistors</p>
<p>+24 V output (XD24:2 and XD24:4)</p>	<p>Connector pitch 5 mm, wire size 0.5 ... 2.5 mm<sup>2</sup> (22...12 AWG) Total load capacity of these outputs is 4.8 W (200 mA / 24 V) minus the power taken by DIO1 and DIO2.</p>
<p>Digital inputs DI1...DI6 (XDI:1...XDI:6)</p>	<p>Connector pitch 5 mm, wire size 0.5 ... 2.5 mm<sup>2</sup> (22...12 AWG) 24 V logic levels: "0" &lt; 5 V, "1" &gt; 15 V <math>R_{in}</math>: 2.0 kohm Input type: NPN/PNP (DI1...DI5), PNP (DI6) Hardware filtering: 0.04 ms, digital filtering up to 8 ms DI6 (XDI:6) can alternatively be used as an input for a PTC sensor. "0" &gt; 4 kohm, "1" &lt; 1.5 kohm. <math>I_{max}</math>: 15 mA (DI1...DI5), 5 mA (DI6)</p>
<p>Start interlock input DIIL (XD24:1)</p>	<p>Connector pitch 5 mm, wire size 0.5 ... 2.5 mm<sup>2</sup> (22...12 AWG) 24 V logic levels: "0" &lt; 5 V, "1" &gt; 15 V <math>R_{in}</math>: 2.0 kohm Input type: NPN/PNP Hardware filtering: 0.04 ms, digital filtering up to 8 ms</p>
<p>Digital inputs/outputs DIO1 and DIO2 (XDIO:1 and XDIO:2) Input/output mode selection by parameters. DIO1 can be configured as a frequency input (0...16 kHz with hardware filtering of 4 microseconds) for 24 V level square wave signal (sinusoidal or other wave form cannot be used). DIO2 can be configured as a 24 V level square wave frequency output. See the firmware manual, parameter group 111/11.</p>	<p>Connector pitch 5 mm, wire size 0.5 ... 2.5 mm<sup>2</sup> (22...12 AWG) <u>As inputs:</u> 24 V logic levels: "0" &lt; 5 V, "1" &gt; 15 V. <math>R_{in}</math>: 2.0 kohm. Filtering: 1 ms. <u>As outputs:</u> Total output current from +24VD is limited to 200 mA</p>  <p>The diagram shows a circuit for a digital input/output. A switch is connected to a +24VD supply. One terminal of the switch is connected to the DIOx pin. The other terminal of the switch is connected to DIOGND. A load resistor RL is connected between the DIOx pin and DIOGND.</p>



Reference voltage for analog inputs +VREF and -VREF (XAI:1 and XAI:2)	Connector pitch 5 mm, wire size 0.5 ... 2.5 mm <sup>2</sup> (22...12 AWG) 10 V ±1% and -10 V ±1%, R <sub>load</sub> 1...10 kohm Maximum output current: 10 mA
Analog inputs AI1 and AI2 (XAI:4 ... XAI:7). Current/voltage input mode selection by jumpers	Connector pitch 5 mm, wire size 0.5 ... 2.5 mm <sup>2</sup> (22...12 AWG) Current input: -20...20 mA, R <sub>in</sub> = 100 ohm Voltage input: -10...10 V, R <sub>in</sub> > 200 kohm Differential inputs, common mode range ±30 V Sampling interval per channel: 0.25 ms Hardware filtering: 0.25 ms, adjustable digital filtering up to 8 ms Resolution: 11 bit + sign bit Inaccuracy: 1% of full scale range
Analog outputs AO1 and AO2 (XAO)	Connector pitch 5 mm, wire size 0.5 ... 2.5 mm <sup>2</sup> (22...12 AWG) 0...20 mA, R <sub>load</sub> < 500 ohm Frequency range: 0...300 Hz Resolution: 11 bit + sign bit Inaccuracy: 2% of full scale range
XD2D connector	Connector pitch 5 mm, wire size 0.5 ... 2.5 mm <sup>2</sup> (22...12 AWG) Physical layer: RS-485 Transmission rate: 8 Mbit/s Cable type: Shielded twisted-pair cable with a twisted pair for data and a wire or another pair for signal ground (nominal impedance 100 ... 165 ohm, for example Belden 9842) Maximum length of link: 50 m (164 ft) Termination by jumper
Safe torque off connection (XSTO)	Connector pitch 5 mm, wire size 0.5 ... 2.5 mm <sup>2</sup> (22...12 AWG) Input voltage range: -3...30 V DC Logic levels: "0" < 5 V, "1" > 17 V.  <b>Note:</b> For the unit to start, both connections must be "1". This applies to all control units (including drive, inverter, supply, brake, DC/DC converter etc. control units), but true Safe torque off functionality is only achieved through the XSTO connector of the drive/inverter control unit. Current consumption: 30 mA (frames R1...R7) or 12 mA (frames R8...R9) (continuous) per STO channel EMC (immunity) according to IEC 61326-3-1 and IEC 61800-5-2
Control panel connection (X13)	Connector: RJ-45 Cable length < 100 m (328 ft)

## 158 Control units of the drive

The terminals of the control unit fulfill the Protective Extra Low Voltage (PELV) requirements. The PELV requirements of a relay output are not fulfilled if a voltage higher than 48 V is connected to the relay output.

---

## ■ ZCU-1x ground isolation diagram

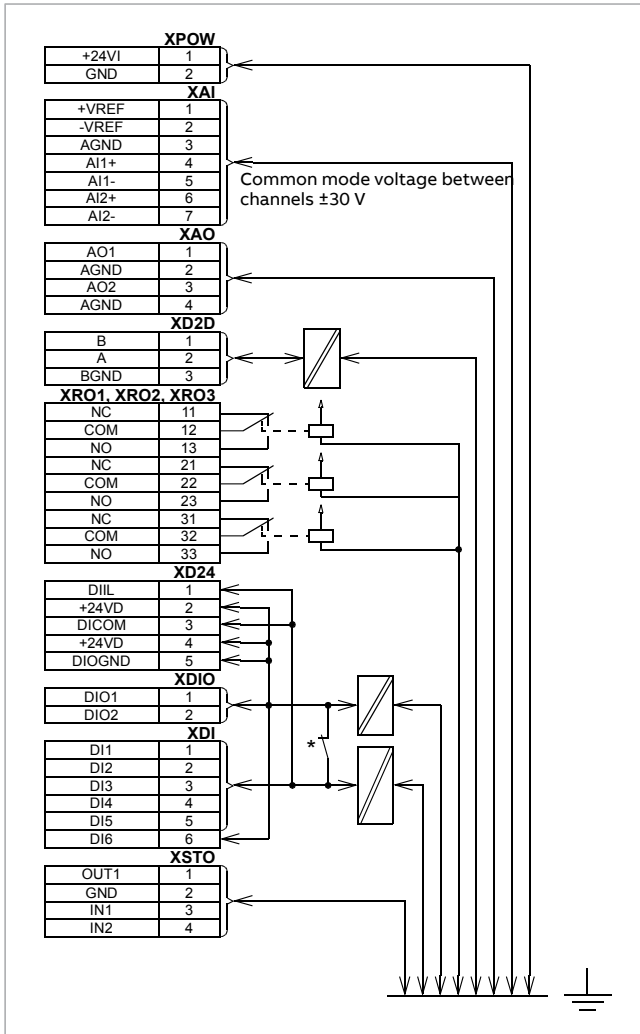

### \* Ground selector (J6) settings



All digital inputs share a common ground (DICOM connected to DIOGND). This is the default setting.

## 160 Control units of the drive



Ground of digital inputs DI1...DI5 and DIIL (DICOM) is isolated from DIO signal ground (DIOGND).

Isolation voltage 50 V.

---

## 9

# Installation checklist

---

## Contents of this chapter

This chapter contains a checklist for the mechanical and electrical installation of the drive.

## Checklist

Examine the mechanical and electrical installation of the drive before start-up. Go through the checklist together with another person.



### **WARNING!**

Obey the safety instructions of the drive. If you ignore them, injury or death, or damage to the equipment can occur. If you are not a qualified electrical professional, do not do installation, commissioning or maintenance work.



### **WARNING!**

Stop the drive and do the steps in section [Electrical safety precautions \(page 18\)](#) before you start the work.

Make sure that ...	<input checked="" type="checkbox"/>
The ambient operating conditions meet the drive ambient conditions specification and enclosure rating (IP code).	<input type="checkbox"/>
The supply voltage matches the nominal input voltage of the drive. See the type designation label.	<input type="checkbox"/>

---

162 Installation checklist

<b>Make sure that ...</b>	<input checked="" type="checkbox"/>
The insulation resistance of the input power cable, motor cable and motor is measured according to local regulations and the manuals of the drive.	<input type="checkbox"/>
The drive is attached securely on an even, vertical and non-flammable wall.	<input type="checkbox"/>
The cooling air flows freely in and out of the drive.	<input type="checkbox"/>
<u>If the drive is connected to a network other than a symmetrically grounded TN-S system:</u> You have done all the required modifications (for example, you may need to disconnect the EMC filter or ground-to-phase varistor). See the electrical installation instructions.	<input type="checkbox"/>
Appropriate AC fuses and main disconnecting device are installed.	<input type="checkbox"/>
There is an adequately sized protective earth (ground) conductor(s) between the drive and the switchboard, the conductor is connected to correct terminal, and the terminal is tightened to the correct torque. Proper grounding has also been measured according to the regulations.	<input type="checkbox"/>
The input power cable is connected to the correct terminals, the phase order is correct, and the terminals are tightened to the correct torque.	<input type="checkbox"/>
There is an adequately sized protective earth (ground) conductor between the motor and the drive. The conductor is connected to the correct terminal, and the terminal is tightened to the correct torque. Proper grounding has also been measured according to the regulations.	<input type="checkbox"/>
The motor cable is connected to the correct terminals, the phase order is correct, and the terminals are tightened to the correct torque.	<input type="checkbox"/>
The motor cable is routed away from other cables.	<input type="checkbox"/>
No power factor compensation capacitors are connected to the motor cable.	<input type="checkbox"/>
<u>If an external brake resistor is connected to the drive:</u> There is an adequately sized protective earth (ground) conductor between the brake resistor and the drive, and the conductor is connected to the correct terminal, and the terminals are tightened to the correct torque. Proper grounding has also been measured according to the regulations.	<input type="checkbox"/>
<u>If an external brake resistor is connected to the drive:</u> The brake resistor cable is connected to the correct terminals, and the terminals are tightened to the correct torque.	<input type="checkbox"/>
<u>If an external brake resistor is connected to the drive:</u> The brake resistor cable is routed away from other cables.	<input type="checkbox"/>
The control cables are connected to the correct terminals, and the terminals are tightened to the correct torque.	<input type="checkbox"/>
<u>If a drive bypass connection will be used:</u> The Direct On Line contactor of the motor and the drive output contactor are either mechanically and/or electrically interlocked, that is, they cannot be closed at the same time. A thermal overload device must be used for protection when bypassing the drive. Refer to local codes and regulations.	<input type="checkbox"/>

<b>Make sure that ...</b>	<input checked="" type="checkbox"/>
There are no tools, foreign objects or dust from drilling inside the drive.	<input type="checkbox"/>
The area in front of the drive is clean: the drive cooling fan cannot draw any dust or dirt inside.	<input type="checkbox"/>
Drive covers and cover of the motor connection box are in place.	<input type="checkbox"/>
The motor and the driven equipment are ready for power-up.	<input type="checkbox"/>

---





# 10

## Start-up

---

### Contents of this chapter

This chapter describes the start-up procedure of the drive.

### Start-up procedure

1. Run setup of the drive control program according to the start-up instructions given in quick start-up guide for ACS880 primary control program or in the firmware manual.
  - For drives with resistor braking (option +D150): see also section Start-up in chapter Resistor braking.
  - For drives with ABB sine filter, check that parameter 95.15 Special HW settings is set to ABB sine filter. For other sine filters, see [Sine filter hardware manual \(3AXD50000016814 \[English\]\)](#).
  - For drives with ABB motors in explosive atmospheres, see also [ACS880 drives with ABB motors in explosive atmospheres \(3AXD50000019585 \[English\]\)](#).
2. Validate the Safe torque off function according to the instructions given in chapter The Safe torque off function.
3. Validate the safety functions (option +Q973 or +Q972) as described in [FSO-12 safety functions module user's manual \(3AXD50000015612 \[English\]\)](#) or in [FSO-21 safety functions module user's manual \(3AXD50000015614 \[English\]\)](#).







# Fault tracing

---

## Contents of this chapter

This chapter describes the fault tracing possibilities of the drive.

### LEDs

Where	LED	Color	When the LED is lit
Control panel mounting platform	POWER	Green	Control unit is powered and +15 V is supplied to the control panel.
	FAULT	Red	Drive in fault state.

#### ■ Warning and fault messages

See the firmware manual for the descriptions, causes and remedies of the drive control program warning and fault messages.

---



# 12

## Maintenance

---

### Contents of this chapter

This chapter contains maintenance instructions.



#### **WARNING!**

Obey the safety instructions of the drive. If you ignore them, injury or death, or damage to the equipment can occur.

---

### Maintenance intervals

The tables below show the maintenance tasks which can be done by the end user. The complete maintenance schedule is available on the Internet (<https://new.abb.com/drives/services/maintenance/preventive-maintenance>). For more information, consult your local ABB Service representative ([www.abb.com/searchchannels](http://www.abb.com/searchchannels)).

#### ■ Description of symbols

Action	Description
I	Inspection (visual inspection and maintenance action if needed)
P	Performance of on/off-site work (commissioning, tests, measurements or other work)
R	Replacement

---

■ Recommended maintenance intervals after start-up

Annual action	Target
P	Quality of supply voltage
I	Spare parts
P	DC circuit capacitor reforming, spare modules and spare capacitors
I	Tightness of terminals
I	Dustiness, corrosion or temperature
I	Heat sink cleaning

Component	Years from start-up							
	3	6	9	12	15	18	20	21
<b>Cooling</b>								
Main cooling fan			R			R		
Auxiliary cooling fan for circuit boards (frames R1 to R9)			R			R		
Auxiliary cooling fan IP55 (frames R8 and R9)			R			R		
<b>Aging</b>								
Battery for ZCU control unit		R		R		R		
Battery for control panel			R			R		
<b>Functional safety</b>								
Safety function test	I See the maintenance information of the safety function							
Safety component expiry (Mission time, $T_M$ )	20 years							
4FPS10000239703								

**Note:**

- Maintenance and component replacement intervals are based on the assumption that the equipment is operated within the specified ratings and ambient conditions. ABB recommends annual drive inspections to ensure the highest reliability and optimum performance.
- Long term operation near the specified maximum ratings or ambient conditions may require shorter maintenance intervals for certain components. Consult your local ABB Service representative for additional maintenance recommendations.

## Cleaning the exterior of the drive

---

**WARNING!**

Obey the safety instructions of the drive. If you ignore them, injury or death, or damage to the equipment can occur. If you are not a qualified electrical professional, do not do installation, commissioning or maintenance work.

---

1. Stop the drive and do the steps in section [Electrical safety precautions](#) (page 18) before you start the work.
  2. Clean the exterior of the drive. Use:
    - vacuum cleaner with an antistatic hose and nozzle
    - soft brush
    - dry or damp (not wet) cleaning cloth. Moisten with clean water, or mild detergent (pH 5-9 for metal, pH 5-7 for plastic).
- 

**WARNING!**

Prevent water from entering the drive. Never use excessive amount of water, a hose, steam, etc.

---

## Cleaning the heatsink

The drive module heatsink fins pick up dust from the cooling air. The drive runs into overtemperature warnings and faults if the heatsink is not clean. When necessary, clean the heatsink as follows.

---

**WARNING!**

Use the required personal protective equipment. Wear protective gloves and long sleeves. Some parts have sharp edges.

---

**WARNING!**

Use a vacuum cleaner with antistatic hose and nozzle, and wear a grounding wristband. Using a normal vacuum cleaner creates static discharges which can damage circuit boards.

---

1. Stop the drive and do the steps in section [Electrical safety precautions](#) (page 18) before you start the work.
  2. Remove the module cooling fan(s). See the separate instructions.
-

3. Blow dry, clean and oil-free compressed air from bottom to top and simultaneously use a vacuum cleaner at the air outlet to trap the dust. If there is a risk of dust entering adjoining equipment, do the cleaning in another room.
4. Reinstall the cooling fan.

## **Fans**

The lifespan of the cooling fans of the drive depend on the running time of the fan, ambient temperature and dust concentration. See the firmware manual for the actual signal which indicates the running time of the cooling fan.

Reset the running time signal after a fan replacement. Also, reset the maintenance counter, if used.

Replacement fans are available from ABB. Do not use other than ABB specified spare parts.

---



### ■ Replacing the main cooling fan of frames R1 to R3

1. Stop the drive and do the steps in section [Electrical safety precautions](#) (page 18) before you start the work.
2. Release the retaining clip by pushing with a flat screwdriver and turning to the right.
3. Lift the fan assembly up.
4. Install the new fan assembly in reverse order. Make sure that the fan blows upwards.
5. Reset the counter (if used) in group 5 in the primary control program.

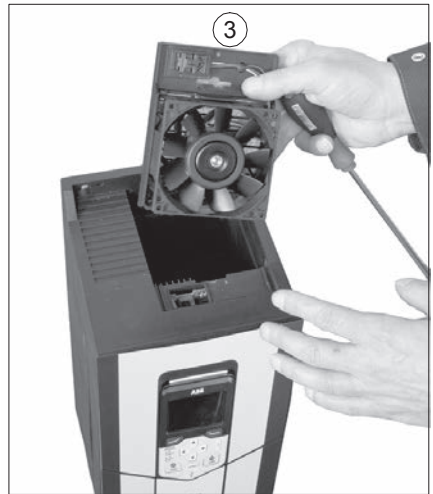

■ **Replacing the auxiliary cooling fan of IP55 frames R1 to R3**

1. Stop the drive and do the steps in section **Electrical safety precautions** (page 18) before you start the work.
2. Remove the front cover by undoing the mounting screws at the sides.
3. Unplug the fan power supply wires. This fan is installed to X210:FAN2 in control unit.
4. Lift the fan off.
5. Install the new fan in reverse order. Make sure that the arrow (5a) on the fan points upwards. Bundle the wires under the clip (5b).

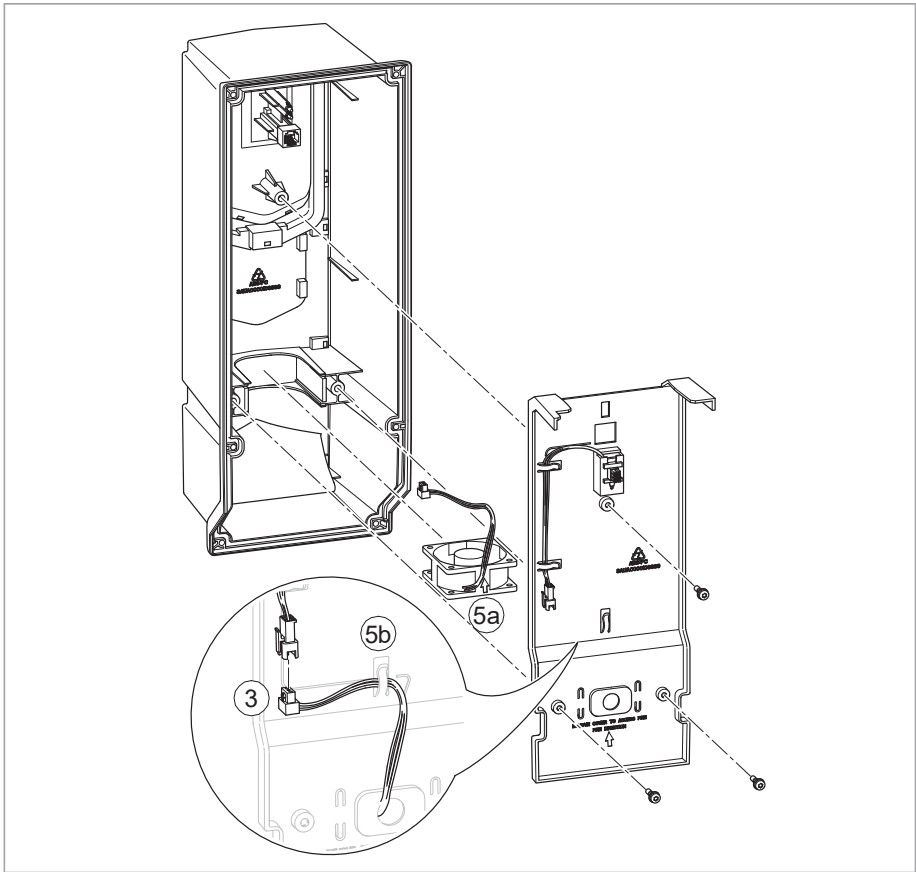

## ■ Replacing the main cooling fan of frames R4 and R5

1. Stop the drive and do the steps in section [Electrical safety precautions](#) (page 18) before you start the work.
2. Lift the fan mounting plate up from the front edge.
3. Unplug the power supply wires.
4. Lift the fan assembly off.
5. Install the new fan assembly in reverse order. Make sure that the fan blows upwards.
6. Reset the counter (if used) in group 5 in the primary control program.



### ■ Replacing the auxiliary cooling fan of frames R4 and R5

This fan is included in R5 types ACS880-01-xxxx-7 and with option +B056+C135.

1. Stop the drive and do the steps in section [Electrical safety precautions](#) (page 18) before you start the work.
2. Remove the front cover.
3. Unplug the fan power supply wires.
4. Lift the fan up.
5. Install the new fan in reverse order. Make sure that the arrow in the fan points to the direction marked on the drive frame.

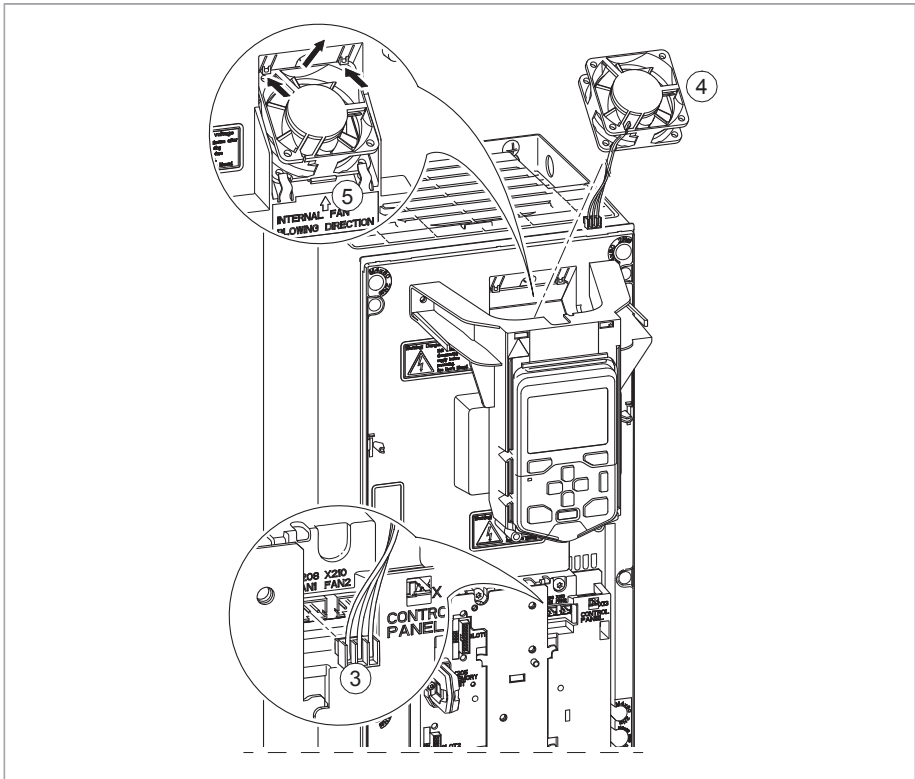

### ■ Replacing the main cooling fan of frames R6 to R8

1. Stop the drive and do the steps in section [Electrical safety precautions](#) (page 18) before you start the work.
2. Undo the mounting screws of the fan mounting plate (view from bottom below).
3. Pull the fan mounting plate down from the side edge.
4. Unplug the power supply wires.
5. Lift the fan mounting plate off.
6. Remove the fan from the mounting plate.
7. Install the new fan in reverse order. Make sure that the fan blows upwards.
8. Reset the counter (if used) in group 5 in the primary control program.

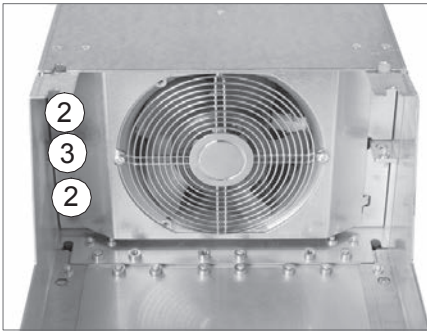

■ **Replacing the auxiliary cooling fan of frames R6 to R9 (IP21, UL Type 1)**

1. Stop the drive and do the steps in section [Electrical safety precautions](#) (page 18) before you start the work.
2. Remove the lower front cover.
3. Unplug the control panel power supply wires from the control unit terminal X13 and the auxiliary cooling fan power supply wires from the terminal X208:FAN1.
4. Remove the upper front cover.
5. Release the retaining clips.
6. Lift the fan up.
7. Install the new fan in reverse order. Make sure that the arrow on the fan points up.

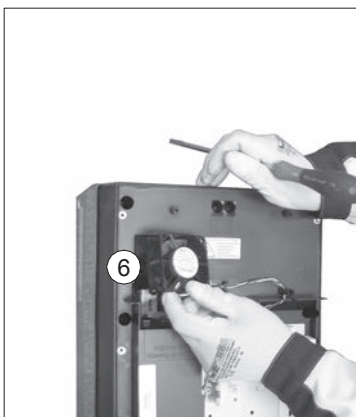
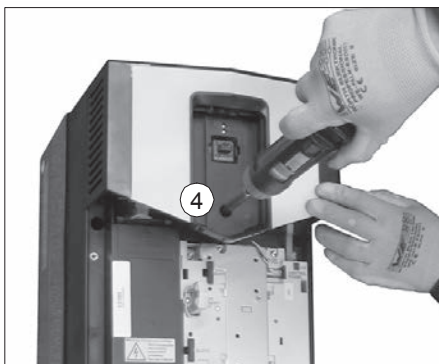
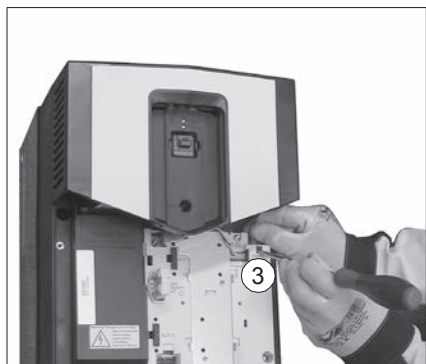

## ■ Replacing the second auxiliary cooling fan of frame R9 (IP55, UL Type 12)

1. Stop the drive and do the steps in section [Electrical safety precautions](#) (page 18) before you start the work.
  2. Remove the IP55 front cover. Disconnect the power supply wire of the auxiliary cooling fan in the cover (see section [Replacing the auxiliary cooling fan in the IP55 \(UL Type 12\) cover, frames R8 and R9](#) (page 180)).
  3. Unplug the fan power supply wires.
  4. Release the retaining clips.
  5. Lift the the fan off.
  6. Unplug the power supply wire from the branching plug.
  7. Install the new fan in reverse order. Make sure that the arrow on the fan points up.
  8. Replace the front cover.
  9. Reset the counter (if used) in group 5 in the primary control program.
-

■ **Replacing the auxiliary cooling fan in the IP55 (UL Type 12) cover, frames R8 and R9**

1. Stop the drive and do the steps in section [Electrical safety precautions \(page 18\)](#) before you start the work.
  2. Remove the lower front cover from the cover.
  3. Unplug the fan power supply wires. This fan is installed to X210:FAN2 in control unit.
  4. Remove the fan.
  5. Install the new fan in reverse order. Make sure that the arrow on the fan points up.
  6. Reset the counter (if used) in group 5 in the primary control program.
-



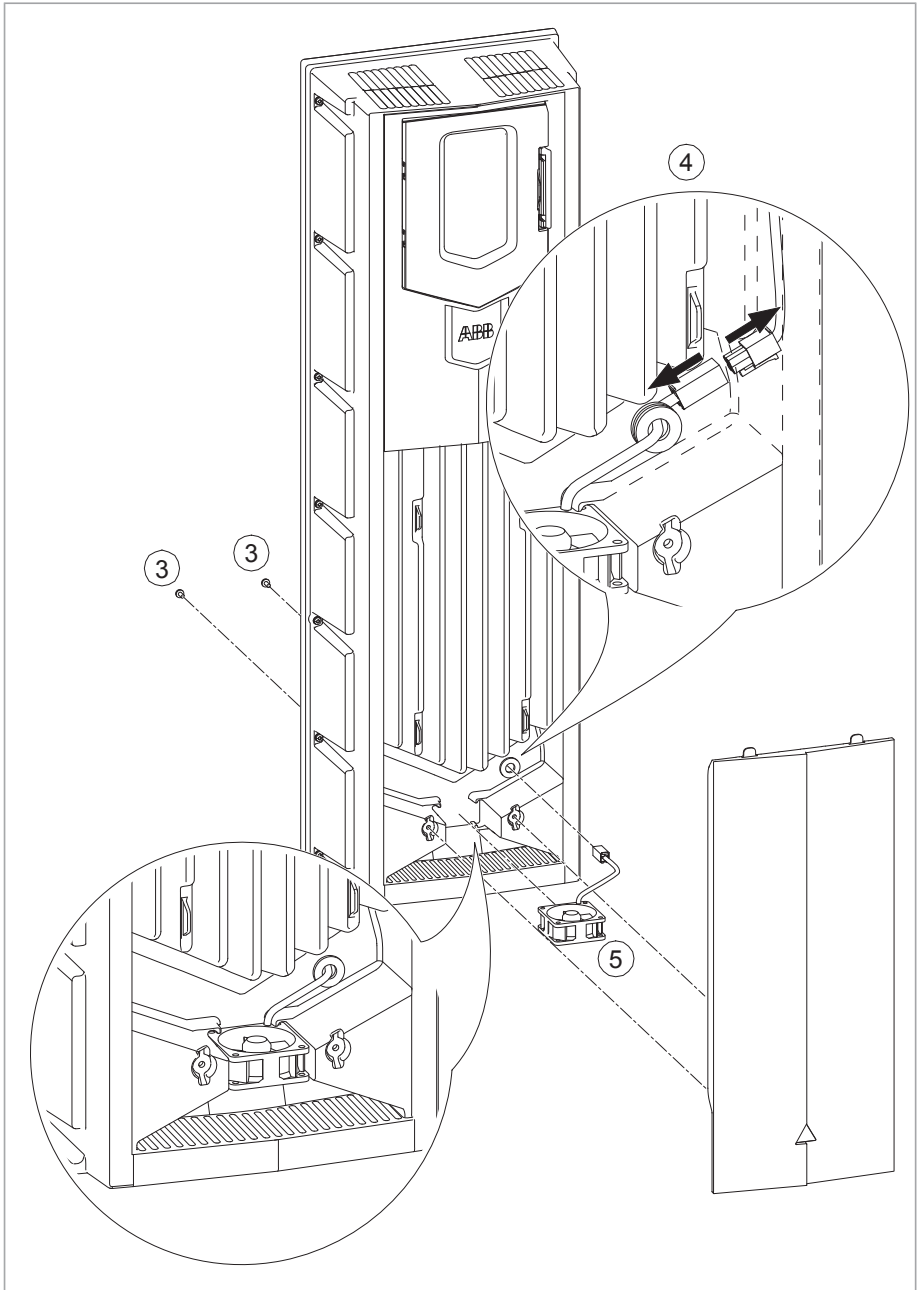

### ■ Replacing the main cooling fans of frame R9

1. Stop the drive and do the steps in section [Electrical safety precautions](#) (page 18) before you start the work.
2. Undo the two mounting screws of the fan mounting plate (view from drive bottom below).
3. Turn the mounting plate downwards.
4. Disconnect the fan power supply wires.
5. Remove the fan mounting plate.
6. Remove the fan by undoing the two mounting screws.
7. Install the new fan in reverse order. Make sure that the fan blows upwards.
8. Reset the counter (if used) in group 5 in the primary control program.

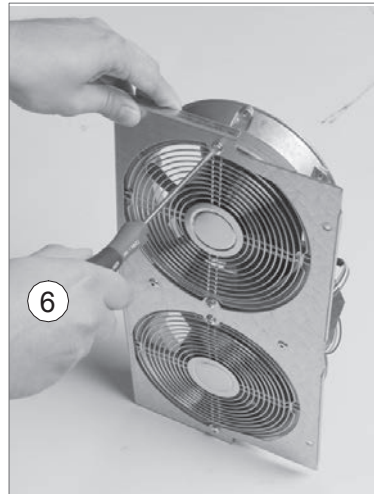
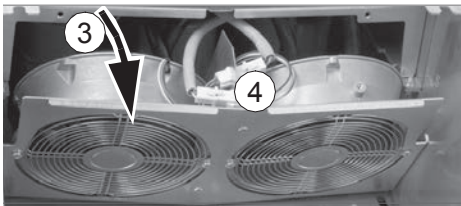
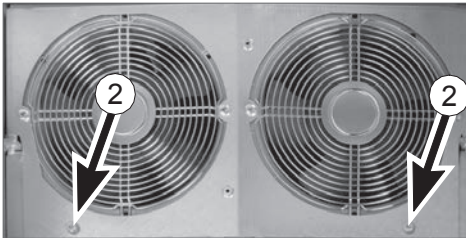

## Replacing the drive (IP21, UL Type 1, frames R1 to R9)

This section gives instructions for replacing the drive module without the cable entry box. This allows you to leave the cables installed (except from disconnecting the conductors).

**Note:** IP55 (UL Type 12) drives: It is not allowed to remove the cable entry box.

1. Stop the drive and do the steps in section [Electrical safety precautions \(page 18\)](#) before you start the work.
  2. Remove the front covers.
  3. For frames R6 to R9: Remove the side plates of the cable entry box by loosening the mounting screws.
  4. Disconnect the power and control cables.
  5. Undo the screw(s) that fasten the drive module to the cable entry box.
  6. Undo the two screws or bolts that attach the drive module to the wall from top.
  7. Undo the two screws or bolts which attach the drive module and cable entry box to the wall. Leave the lower wall mounting screws of the cable box in place.
  8. Lift the drive off.
  9. Install the new drive module in reverse order.
-

R1...R3

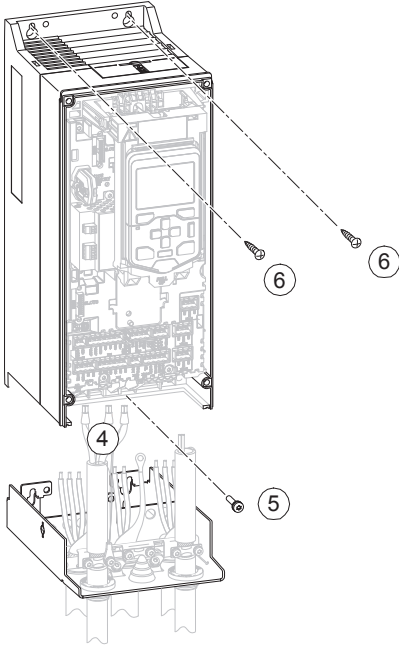

R4, R5

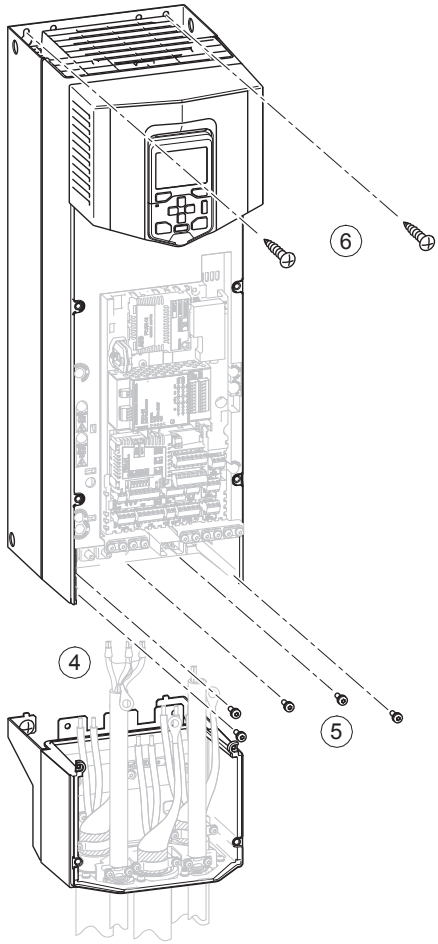

## Capacitors

The DC link of the drive contains several electrolytic capacitors. Operating time, load, and surrounding air temperature have an effect on the life of the capacitors. Capacitor life can be extended by decreasing the surrounding air temperature.

Capacitor failure is usually followed by damage to the unit and an input cable fuse failure, or a fault trip. If you think that any capacitors in the drive have failed, contact ABB.

### ■ Reforming the capacitors

The capacitors must be reformed if the drive has not been powered (either in storage or unused) for a year or more. The manufacturing date is on the type designation label. For information on reforming the capacitors, refer to [Capacitor reforming instructions \(3BFE64059629 \[English\]\)](#).

## Control panel

See [ACS-AP-I, -S, -W and ACH-AP-H, -W Assistant control panels user's manual \(3AUA0000085685 \[English\]\)](#).

## Control unit

### ■ Replacing the memory unit of ZCU-12

After replacing a control unit, you can retain the existing parameter settings by transferring the memory unit from the defective control unit to the new control unit. After power-up, the drive will scan the memory unit. This can take several minutes.



#### **WARNING!**

Do not remove or insert the memory unit when the control unit is powered.

---

1. Stop the drive and do the steps in section [Electrical safety precautions \(page 18\)](#) before you start the work.
  2. Pull the clip at the side of the memory up.
-

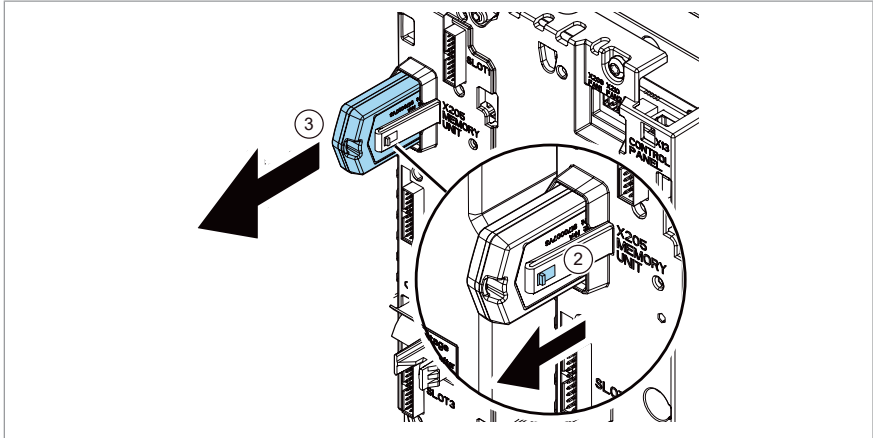

3. Take the unit off.
4. Install the unit in reverse order.

■ **Replacing the ZCU-12 control unit battery**

The ZCU-12 control unit produced after week 13 2022 does not have a battery in it.

**Replacing safety functions modules (FSO-12, option +Q973 and FSO-21, option +Q972)**

Do not repair safety functions modules. Replace a faulty module with a new one as described in section [Installing FSO-xx safety functions modules \(page 125\)](#).

**Functional safety components**

The mission time of functional safety components is 20 years which equals the time during which failure rates of electronic components remain constant. This applies to the components of the standard Safe torque off circuit as well as any modules, relays and, typically, any other components that are part of functional safety circuits.

The expiry of mission time terminates the certification and SIL/PL classification of the safety function. The following options exist:

- Renewal of the whole drive and all optional functional safety module(s) and components.
- Renewal of the components in the safety function circuit. In practice, this is economical only with larger drives that have replaceable circuit boards and other components such as relays.

Note that some of the components may already have been renewed earlier, restarting their mission time. The remaining mission time of the whole circuit is however determined by its oldest component.

Contact your local ABB service representative for more information.







# 13

## Technical data

---

### Contents of this chapter

This chapter contains the technical specifications of the drive including the ratings, sizes and technical requirements, provisions for fulfilling the requirements for CE, UL and other approval marks.

### Marine type-approved drives (option +C132)

See [ACS880-01/04 +C132 marine type-approved drives supplement \(3AXD50000010521 \[English\]\)](#) for the ratings, marine-specific data and reference to valid marine type approvals.

### Drives for SynRM motors

See [ACS880-01 drives for SynRM motors supplement \(3AXD50000029482 \[English\]\)](#) for the ratings, fuses and other technical data.

---

## Ratings

The nominal ratings for the drives with 50 Hz and 60 Hz supply are given below. The symbols are described below the tables. ABB recommends the DriveSize dimensioning tool for selecting the drive, motor and gear combination.

IEC RATINGS											
ACS880-01-...	Frame size	Input rating	Output ratings								
			Nominal use					Light-duty use		Heavy-duty use	
			$I_1$	$I_{max}$	$I_2$	$P_n$	$S_n$	$I_{Ld}$	$P_{Ld}$	$I_{Hd}$	$P_{Hd}$
			A	A	A	kW	kVA	A	kW	A	kW
$U_n = 230 V$											
04A6-2	R1	4.6	6.3	4.6	0.75	1.8	4.4	0.75	3.7	0.55	
06A6-2	R1	6.6	7.8	6.6	1.1	2.6	6.3	1.1	4.6	0.75	
07A5-2	R1	7.5	11.2	7.5	1.5	3.0	7.1	1.5	6.6	1.1	
10A6-2	R1	10.6	12.8	10.6	2.2	4.2	10.1	2.2	7.5	1.5	
16A8-2	R2	16.8	18.0	16.8	4.0	7	16.0	4.0	10.6	2.2	
24A3-2	R2	24.3	28.6	24.3	5.5	10	23.1	5.5	16.8	4.0	
031A-2	R3	31.0	41	31	7.5	12	29.3	7.5	24.3	5.5	
046A-2	R4	46	64	46	11	18	44	11	38	7.5	
061A-2	R4	61	76	61	15	24	58	15	45	11.0	
075A-2	R5	75	104	75	18.5	30	71	18.5	61	15	
087A-2	R5	87	122	87	22	35	83	22	72	18.5	
115A-2	R6	115	148	115	30	46	109	30	87	22	
145A-2	R6	145	178	145	37	58	138	37	105	30	
170A-2	R7	170	247	170	45	68	162	45	145	37	
206A-2	R7	206	287	206	55	82	196	55	169	45	
274A-2	R8	274	362	274	75	109	260	75	213	55	
$U_n = 400 V$											
02A4-3	R1	2.4	3.1	2.4	0.75	1.7	2.3	0.75	1.8	0.55	
03A3-3	R1	3.3	4.1	3.3	1.1	2.3	3.1	1.1	2.4	0.75	
04A0-3	R1	4.0	5.6	4.0	1.5	2.8	3.8	1.5	3.3	1.1	
05A6-3	R1	5.6	6.8	5.6	2.2	3.9	5.3	2.2	4.0	1.5	
07A2-3	R1	8.0	9.5	8.0	3.0	5.5	7.6	3.0	5.6	2.2	
09A4-3	R1	10.0	12.2	10.0	4.0	6.9	9.5	4.0	8.0	3.0	
12A6-3	R1	12.9	16.0	12.9	5.5	8.9	12.0	5.5	10.0	4.0	
017A-3	R2	17	21	17	7.5	12	16	7.5	12.6	5.5	
025A-3	R2	25	29	25	11	17	24	11	17	7.5	
032A-3	R3	32	42	32	15	22	30	15	25	11	
038A-3	R3	38	54	38	18.5	26	36	18.5	32	15.0	
045A-3	R4	45	64	45	22	31	43	22	38	18.5	

IEC RATINGS											
ACS880-01-...	Frame size	Input rating	Output ratings								
			Nominal use				Light-duty use		Heavy-duty use		
			$I_1$	$I_{max}$	$I_2$	$P_n$	$S_n$	$I_{Ld}$	$P_{Ld}$	$I_{Hd}$	$P_{Hd}$
			A	A	A	kW	kVA	A	kW	A	kW
061A-3	R4	61	76	61	30	42	58	30	45	22	
072A-3	R5	72	104	72	37	50	68	37	61	30	
087A-3	R5	87	122	87	45	60	83	45	72	37	
105A-3	R6	105	148	105	55	73	100	55	87	45	
145A-3	R6	145	178	145	75	100	138	75	105	55	
169A-3	R7	169	247	169	90	117	161	90	145	75	
206A-3	R7	206	287	206	110	143	196	110	169	90	
246A-3	R8	246	350	246	132	170	234	132	206	110	
293A-3	R8	293	418	293	160	203	278	160	246*	132	
363A-3	R9	363	498	363	200	251	345	200	293	160	
430A-3	R9	430	545	430	250	298	400	200	363**	200	
$U_n = 400\text{ V}$											
02A1-5	R1	2.1	3.1	2.1	0.75	1.8	2.0	0.55	1.7	0.55	
03A0-5	R1	3.0	4.1	3.0	1.1	2.6	2.8	1.1	2.1	0.75	
03A4-5	R1	3.4	5.6	3.4	1.1	2.9	3.2	1.1	3.0	1.1	
04A8-5	R1	4.8	6.8	4.8	1.5	4.2	4.6	1.5	3.4	1.1	
05A2-5	R1	5.2	9.5	5.2	2.2	4.5	5.0	2.2	4.8	1.5	
07A6-5	R1	7.6	12.2	7.6	3.0	6.6	7.2	3.0	5.2	2.2	
11A0-5	R1	11.0	16.0	11.0	4.0	9.5	10.4	4.0	7.6	3.0	
014A-5	R2	14	21	14	5.5	12	13	5.5	11	4.0	
021A-5	R2	21	29	21	7.5	18	19	7.5	14	5.5	
027A-5	R3	27	42	27	11.0	23	26	11.0	21	7.5	
034A-5	R3	34	54	34	15.0	29	32	15.0	27	11	
040A-5	R4	40	64	40	18.5	35	38	18.5	34	15	
052A-5	R4	52	76	52	22	45	49	22	40	18.5	
065A-5	R5	65	104	65	30	56	62	30	52	22	
077A-5	R5	77	122	77	37	67	73	37	65	30	
096A-5	R6	96	148	96	45	83	91	45	77	37	
124A-5	R6	124	178	124	55	107	118	55	96	45	
156A-5	R7	156	247	156	75	135	148	75	124	55	
180A-5	R7	180	287	180	90	156	171	90	156	75	
240A-5	R8	240	350	240	110	208	228	110	180	90	
260A-5	R8	260	418	260	132	225	247	132	240*	110	
361A-5	R9	361	542	361	200	313	343	160	302	160	

IEC RATINGS											
ACS880-01-...	Frame size	Input rating	Output ratings								
			Nominal use				Light-duty use		Heavy-duty use		
			$I_1$	$I_{max}$	$I_2$	$P_n$	$S_n$	$I_{Ld}$	$P_{Ld}$	$I_{Hd}$	$P_{Hd}$
			A	A	A	kW	kVA	A	kW	A	kW
414A-5	R9	414	542	414	200	359	393	200	361**	200	
$U_n = 500\text{ V}$											
02A1-5	R1	2.1	3.1	2.1	0.75	1.8	2.0	0.75	1.7	0.55	
03A0-5	R1	3.0	4.1	3.0	1.1	2.6	2.8	1.1	2.1	0.75	
03A4-5	R1	3.4	5.6	3.4	1.5	2.9	3.2	1.5	3.0	1.1	
04A8-5	R1	4.8	6.8	4.8	2.2	4.2	4.6	2.2	3.4	1.5	
05A2-5	R1	5.2	9.5	5.2	3.0	4.5	4.9	3.0	4.8	2.2	
07A6-5	R1	7.6	12.2	7.6	4.0	6.6	7.2	4.0	5.2	3.0	
11A0-5	R1	11.0	16.0	11.0	5.5	9.5	10.4	5.5	7.6	4.0	
014A-5	R2	14	21	14	7.5	12	13	7.5	11	5.5	
021A-5	R2	21	29	21	11	18	19	11	14	7.5	
027A-5	R3	27	42	27	15	23	26	15	21	11	
034A-5	R3	34	54	34	18.5	29	32	18.5	27	15	
040A-5	R4	40	64	40	22	35	38	22	34	19	
052A-5	R4	52	76	52	30	45	49	30	40	22	
065A-5	R5	65	104	65	37	56	62	37	52	30	
077A-5	R5	77	122	77	45	67	73	45	65	37	
096A-5	R6	96	148	96	55	83	91	55	77	45	
124A-5	R6	124	178	124	75	107	118	75	96	55	
156A-5	R7	156	247	156	90	135	148	90	124	75	
180A-5	R7	180	287	180	110	156	171	110	156	90	
240A-5	R8	240	350	240	132	208	228	132	180	110	
260A-5	R8	260	418	260	160	225	247	160	240*	132	
361A-5	R9	361	542	361	200	313	343	200	302	200	
414A-5	R9	414	542	414	250	359	393	250	361**	200	
$U_n = 690\text{ V}$											
07A4-7	R3	7.4	12.2	7.4	5.5	8.8	7.0	5.5	5.6	4	
09A9-7	R3	9.9	18	9.9	7.5	11.8	9.4	7.5	7.4	5.5	
14A3-7	R3	14.3	22	14.3	11	17	13.6	11	9.9	7.5	
019A-7	R3	19	29	19	15	23	18	15	14.3	11	
023A-7	R3	23	38	23	18.5	27	22	18.5	19	15	
027A-7	R3	27	46	27	22	32	26	22	23	18.5	
035A-7	R5	35	64	35	30	42	33	30	26	22	
042A-7	R5	42	70	42	37	50	40	37	35	30	

IEC RATINGS											
ACS880-01-...	Frame size	Input rating	Output ratings								
			Nominal use				Light-duty use		Heavy-duty use		
			$I_1$	$I_{max}$	$I_2$	$P_n$	$S_n$	$I_{Ld}$	$P_{Ld}$	$I_{Hd}$	$P_{Hd}$
			A	A	A	kW	kVA	A	kW	A	kW
049A-7	R5	49	71	49	45	59	47	45	42	37	
061A-7	R6	61	104	61	55	73	58	55	49	45	
084A-7	R6	84	124	84	75	100	80	75	61	55	
098A-7	R7	98	168	98	90	117	93	90	84	75	
119A-7	R7	119	198	119	110	142	113	110	98	90	
142A-7	R8	142	250	142	132	170	135	132	119	110	
174A-7	R8	174	274	174	160	208	165	160	142	132	
210A-7	R9	210	384	210	200	251	200	200	174	160	
271A-7	R9	271	411	271	250	324	257	250	210	200	

UL (NEC) RATINGS											
ACS880-01-...	Frame size	Input rating	Output ratings								
			Max. current	App. power	Light-duty use			Heavy-duty use			
			$I_1$	$I_{max}$	$S_n$	$I_{Ld}$	$P_{Ld}$		$I_{Hd}$	$P_{Hd}$	
			A	A	kVA	A	kW	hp	A	kW	hp
$U_n = 230\text{ V}$											
04A6-2	R1	4.4	6.3	1.8	4.4	0.75	1.0	3.7	0.55	0.75	
06A6-2	R1	6.3	7.8	2.6	6.3	1.1	1.5	4.6	0.75	1.0	
07A5-2	R1	7.1	11.2	3.0	7.1	1.5	2.0	6.6	1.1	1.5	
10A6-2	R1	10.1	12.8	4.2	10.1	2.2	3.0	7.5	1.5	2.0	
16A8-2	R2	16.0	18.0	7	16.0	4.0	5.0	10.6	2.2	3.0	
24A3-2	R2	23.1	28.6	10	23.1	5.5	7.5	16.8	4.0	5.0	
031A-2	R3	29.3	41	12	29.3	7.5	10	24.3	5.5	7.5	
046A-2	R4	44	64	18	44	11	15	38	7.5	10	
061A-2	R4	58	76	24	58	15	20	45	11.0	15	
075A-2	R5	71	104	30	71	18.5	25	61	15	20	
087A-2	R5	83	122	35	83	22	30	72	18.5	25	
115A-2	R6	109	148	46	109	30	40	87	22	30	
145A-2	R6	138	178	58	138	37	50	105	30	40	
170A-2	R7	162	247	68	162	45	60	145	37	50	
206A-2	R7	196	287	82	196	55	75	169	45	60	

UL (NEC) RATINGS												
ACS880-01-...	Frame size	Input rating	Output ratings									
			Max. current	App. power	Light-duty use			Heavy-duty use				
					$I_{1max}$	$S_n$	$I_{Ld}$	$P_{Ld}$		$I_{Hd}$	$P_{Hd}$	
					A	kVA	A	kW	hp	A	kW	hp
274A-2	R8	260	362	109	260	75	100	213	55	75		
$U_n = 480\text{ V}$												
02A1-5	R1	2.1	3.1	1.8	2.1	0.75	1.0	1.7	0.55	0.75		
03A0-5	R1	3.0	4.1	2.6	3.0	1.1	1.5	2.1	0.75	1.0		
03A4-5	R1	3.4	5.6	2.9	3.4	1.5	2.0	3.0	1.1	1.5		
04A8-5	R1	4.8	6.8	4.2	4.8	2.2	3.0	3.4	1.5	2.0		
05A2-5	R1	5.2	9.5	4.5	5.2	3.0	3.0	4.8	1.5	2.0		
07A6-5	R1	7.6	12.2	6.6	7.6	4.0	5.0	5.2	2.2	3.0		
11A0-5	R1	11	16.0	9.5	11	5.5	7.5	7.6	4.0	5.0		
014A-5	R2	14	21	12	14	7.5	10	11	5.5	7.5		
021A-5	R2	21	29	18	21	11	15	14	7.5	10		
027A-5	R3	27	42	23	27	15	20	21	11	15		
034A-5	R3	34	54	29	34	18.5	25	27	15	20.0		
040A-5	R4	40	64	35	40	22	30	34	18.5	25		
052A-5	R4	52	76	45	52	30	40	40	22	30		
065A-5	R5	65	104	56	65	37	50	52	30	40		
077A-5	R5	77	122	67	77	45	60	65	37	50		
096A-5	R6	96	148	83	96	55	75	77	45	60		
124A-5	R6	124	178	107	124	75	100	96	55	75		
156A-5	R7	156	247	135	156	90	125	124	75	100		
180A-5	R7	180	287	156	180	110	150	156	90	125		
240A-5	R8	240	350	208	240	132	200	180	110	150		
260A-5	R8	260	418	225	260	132	200	240*	110	150		
302A-5	R9	302	498	262	302	200	250	260	132	200		
361A-5	R9	361	542	313	361	200	300	302	200	250		
414A-5	R9	414	542	359	414*	250	350	361**	200	300		
$U_n = 575\text{ V}$												
07A4-7	R3	7.0	12.2	8.8	7.0	4.0	5.0	5.6	3.0	3.0		
09A9-7	R3	9.4	18	11.8	9.4	5.5	7.5	7.4	4.0	5.0		
14A3-7	R3	13.6	22	17	13.6	7.5	10	9.9	5.5	7.5		
019A-7	R3	18	29	23	18	11	15	14.3	7.5	10		
023A-7	R3	22	38	27	22	15	20	19	11	15		
027A-7	R3	27	46	32	27	18.5	25	23	15	20		
035A-7	R5	41	64	42	41	30	40	32	22	30		

UL (NEC) RATINGS											
ACS880-01-...	Frame size	Input rating	Output ratings								
			Max. current	App. power	Light-duty use			Heavy-duty use			
			$I_1$	$I_{max}$	$S_n$	$I_{Ld}$	$P_{Ld}$		$I_{Hd}$	$P_{Hd}$	
			A	A	kVA	A	kW	hp	A	kW	hp
042A-7	R5	52	70	50	52	37	50	41	30	40	
049A-7	R5	52	71	59	52	37	50	41	30	40	
061A-7	R6	62	104	73	62	45	60	52	37	50	
084A-7	R6	77	124	100	77	55	75	62	45	60	
098A-7	R7	99	168	117	99	75	100	77	55	75	
119A-7	R7	125	198	142	125	90	125	99	75	100	
142A-7	R8	144	250	170	144	110	150	125	90	125	
174A-7 (See Note 4 below)	R8	180	274	208	180	132	200	144	110	150	
210A-7	R9	242	384	251	242	160	250	192	132	200	
271A-7 (See Note 5 below)	R9	271	411	324	271	200	250	242*	160	250	

## ■ Definitions

- $U_n$  Nominal voltage of the drive
- $I_1$  Nominal rms input current
- $I_2$  Nominal output current (available continuously with no over-loading)
- $P_n$  Typical motor power in no-overload use
- $S_n$  Apparent power
- $I_{Ld}$  Continuous rms output current allowing 10% overload for 1 minute every 5 minutes  
\*  $I_{Ld}$  is 414 A in 30 °C ambient temperature and 393 A in 40 °C ambient temperature.  
The drive can deliver 414 A continuously with no overload in 40 °C.
- $P_{Ld}$  Typical motor power in light-overload use
- $I_{max}$  Maximum output current. Available for 10 seconds at start. then as long as allowed by drive temperature.
- $I_{Hd}$  Continuous rms output current allowing 50% overload for 1 minute every 5 minutes.  
\* Continuous rms output current allowing 30% overload for 1 minute every 5 minutes.  
\*\* Continuous rms output current allowing 25% overload for 1 minute every 5 minutes.
- $P_{Hd}$  Typical motor power in heavy-duty use

**Note 1:** The ratings apply at an ambient temperature of 40 °C (104 °F).

**Note 2:** To achieve the rated motor power given in the table, the rated current of the drive must be greater than or equal to the rated motor current.

**Note 3:** Typical motor power for 480 V UL (NEC) ratings applies to 460 V motors.

**Note 4 – ACS880-01-174A-7 amp rating:** The drive can deliver 192 A continuously with no overload.

**Note 5 – ACS880-01-271A-7 power rating:** The power rating is as per NEC Table 42.1. However, the drive can be used for a typical 4-pole motor rated to 300 hp meeting NEMA MG 1 Table 12-11 minimum efficiency standard (EPA efficiency electrical motors) if motor full load current is not more than 271 A.

## ■ Deratings

### Surrounding air temperature derating

#### IP21 (UL Type 1) drives and IP55 (UL Type 12) frames R1...R7 and R9.

In the temperature range +40...55 °C (+104...131 °F), the rated output current is derated by 1% for every added 1 °C (1.8 °F).

To calculate the output current, multiply the current in the ratings table by the derating factor (k):

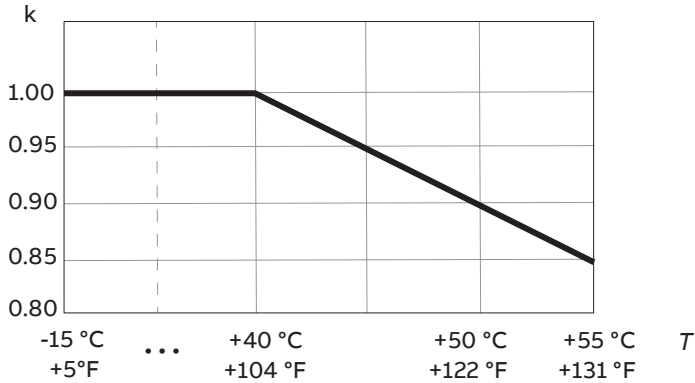

**IP55 (UL Type 12) frame R8**

ACS880-01-...	Derated output current ( $I_2$ )					Frame
	35 °C (95 °F)	40 °C (104 °F)	45 °C (113 °F)	50 °C (122 °F)	55 °C (131 °F)	
$U_N = 230\text{ V}$						
274A-2	274	274	260	226	192	R8
$U_N = 400\text{ V}$						
246A-3	246	246	234	221	209	R8
293A-3	293	293	278	242	209	R8
$U_N = 500\text{ V}$						
240A-5	240	240	228	216	186	R8
260A-5	260	260	247	216	186	R8
$U_N = 690\text{ V}$						
142A-7	142	142	135	128	121	R8
174A-7	174	174	165	144	122	R8

ACS880-01-...	Derated output current ( $I_{Ld}$ )					Frame
	35 °C (95 °F)	40 °C (104 °F)	45 °C (113 °F)	50 °C (122 °F)	55 °C (131 °F)	
$U_N = 230\text{ V}$						
274A-2	260	260	247	215	182	R8

ACS880-01-...	Derated output current ( $I_{Hd}$ )					Frame
	35 °C (95 °F)	40 °C (104 °F)	45 °C (113 °F)	50 °C (122 °F)	55 °C (131 °F)	
$U_N = 230\text{ V}$						
274A-2	213	213	202	176	149	R8

### Altitude derating

At altitudes above 1000 m (3281 ft) above sea level, the output current derating is 1 percentage point for every added 100 m (328 ft). For example, the derating factor for 1500 m (4921 ft) is 0.95. The maximum permitted installation altitude is given in the technical data.

If the surrounding air temperature is less than +40 °C (104 °F), the derating can be reduced by 1.5 percentage points for every 1 °C (1.8 °F) reduction in temperature. A few altitude derating curves are shown below.

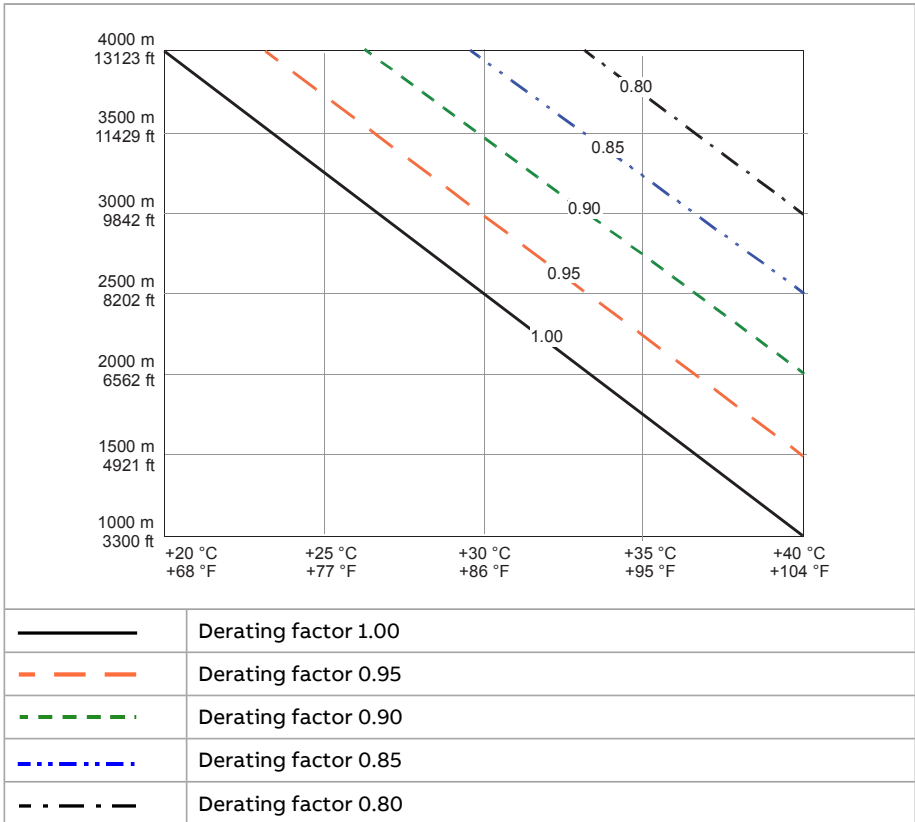

For a more accurate derating, use the DriveSize PC tool.

### Deratings for special settings in the drive control program

Enabling special settings in the drive control program can require output current derating.

### Ex motor, sine filter, low noise

Deratings are needed in these cases:

- drive is used with an ABB motor for explosive atmospheres (Ex) and "EX motor" in parameter 95.15 Special HW settings is enabled
- sine filter given in the selection table in chapter Filters is used and "ABB Sine filter" in parameter 95.15 Special HW settings is enabled
- "Low noise optimization" is selected in parameter 97.09 Switching freq mode.

**Note:** If Ex motors are used together with sine filters, "EX motor" in parameter 95.15 Special HW settings is disabled and "ABB Sine filter" in parameter 95.15 Special HW settings is enabled. Obey the instructions of the motor manufacturer.

With other than recommended sine filters and non-ABB Ex motors, contact ABB.

ACS880-01-...	Setting of parameter 9.15: Ex motor enabled				Setting of parameter 9.15: ABB sine filter enabled			
	Drive output ratings				Drive output ratings			
	Nominal use		Light-duty use	Heavy-duty use	Nominal use		Light-duty use	Heavy-duty use
	$I_2$	$P_n$	$I_{Ld}$	$I_{Hd}$	$I_2$	$P_n$	$I_{Ld}$	$I_{Hd}$
	A	kW	A	A	A	kW	A	A
$U_n = 230\text{ V}$								
04A6-2	4.6	0.75	4.4	3.7	4.3	0.55	4.1	3.5
06A6-2	6.6	1.1	6.3	4.6	6.2	0.8	5.9	4.3
07A5-2	7.5	1.5	7.1	6.6	7.4	1.5	7.0	6.2
10A6-2	10.6	2.2	10.1	7.5	10.0	2.2	9.5	7.4
16A8-2	16.8	4.0	16.0	10.6	15.9	4.0	15.1	10.0
24A3-2	24.3	5.5	23.1	16.8	23.1	5.5	21.9	15.9
031A-2	31	7.5	29.3	24.3	30.5	7.5	29.0	23.1
046A-2	46	11.0	44	38	43.0	11.0	41	31
061A-2	61	15	58	45	58	15	55	41
075A-2	75	19	71	61	65	15	62	55
087A-2	87	22	83	72	77	18.5	73	62
115A-2	106	22	101	87	100	22	95	73
145A-2	134	30	127	105	126	30	120	95
170A-2	161	37	153	134	153	37	145	120
206A-2	195	45	185	161	186	45	177	145
274A-2	251	55	238	195	233	55	221	169
$U_n = 400\text{ V}$								
02A4-3	2.4	0.75	2.3	1.80	2.3	0.75	2.2	1.7
03A3-3	3.3	1.1	3.1	2.4	3.1	1.1	2.9	2.3

200 Technical data

ACS880-01-...	Setting of parameter 9.15: Ex motor enabled				Setting of parameter 9.15: ABB sine filter enabled			
	Drive output ratings				Drive output ratings			
	Nominal use		Light-duty use	Heavy-duty use	Nominal use		Light-duty use	Heavy-duty use
	$I_2$	$P_n$	$I_{Ld}$	$I_{Hd}$	$I_2$	$P_n$	$I_{Ld}$	$I_{Hd}$
	A	kW	A	A	A	kW	A	A
04A0-3	4.0	1.5	3.8	3.3	3.8	1.5	3.6	3.1
05A6-3	5.6	2.2	5.3	4.0	5.3	2.2	5.0	3.8
07A2-3	8.0	3.0	7.6	5.6	7.2	3.0	6.8	5.3
09A4-3	10.0	4.0	9.5	8.0	9.2	4.0	8.7	7.2
12A6-3	12.9	5.5	12.0	10.0	12.1	5.5	11.5	9.2
017A-3	17	8	16	12.6	16	7.5	15	12
025A-3	25	11	24	17	24	11	23	16
032A-3	32	15	30	25	31	15	29	23
038A-3	38	19	36	32	37	18.5	35	31
045A-3	45	22	43	38	43	22	41	36
061A-3	61	30	58	45	58	30	55	43
072A-3	72	37	68	61	64	30	61	58
087A-3	87	45	83	72	77	37	73	64
105A-3	97	45	92	87	91	45	86	77
145A-3	134	55	127	97	126	55	120	91
169A-3	160	75	152	134	152	75	144	126
206A-3	195	90	185	160	186	90	177	152
246A-3	225	110	214	195	209	110	199	186
293A-3	269	132	256	225*	249	132	237	209*
363A-3	325	160	309	269	296	160	281	249
430A-3	385	200	366	325**	352	160	334	296**
$U_n = 500\text{ V}$								
02A1-5	2.1	0.75	2.0	1.7	1.9	0.55	1.8	1.5
03A0-5	3.0	1.1	2.8	2.1	2.8	0.75	2.7	1.9
03A4-5	3.4	1.5	3.2	3.0	3.1	1.1	2.9	2.8
04A8-5	4.8	2.2	4.6	3.4	4.4	1.5	4.2	3.1
05A2-5	5.2	3.0	5.0	4.8	4.8	2.2	4.6	4.4
07A6-5	7.6	4.0	7.2	5.2	7.0	3.0	6.7	4.8
11A0-5	11.0	5.5	10.4	7.6	10.2	4.0	9.7	7.0
014A-5	14	7.5	13	11	13	5.5	12	10.2
021A-5	21	11.0	19	14	19	7.5	18	13
027A-5	27	15	26	21	25	11.0	24	19.0
034A-5	34	18.5	32	27.0	31	15	29	25

ACS880-01-...	Setting of parameter 9.15: Ex motor enabled				Setting of parameter 9.15: ABB sine filter enabled			
	Drive output ratings				Drive output ratings			
	Nominal use		Light-duty use	Heavy-duty use	Nominal use		Light-duty use	Heavy-duty use
	$I_2$	$P_n$	$I_{Ld}$	$I_{Hd}$	$I_2$	$P_n$	$I_{Ld}$	$I_{Hd}$
	A	kW	A	A	A	kW	A	A
040A-5	40	22	38	34	34	18.5	32	31.0
052A-5	52	30	49	40	44	22	42	34
065A-5	65	37	62	52	52	30	49	44
077A-5	77	45	73	65	61	37	58	52
096A-5	88	45	84	77	82	45	78	61
124A-5	115	55	109	88	104	55	99	82
156A-5	147	75	140	115	140	75	133	104
180A-5	170	90	162	147	161	90	153	140
240A-5	220	110	209	170	204	110	194	161
260A-5	238	132	226	220*	221	110	210	204*
302A-5	270	160	257	238	242	132	230	221
361A-5	322	200	306	270	289	160	275	242
414A-5	370	200	352	322**	332	200	315	289**
$U_n = 690 \text{ V}$								
07A4-7	7.4	5.5	7.0	5.6	7.0	4.0	6.7	5.6
09A9-7	9.9	7.5	9.4	7.4	9.4	5.5	8.9	7.0
14A3-7	14.3	11	13.6	9.9	13.6	7.5	12.9	9.4
019A-7	19	15	18	14.3	18	11	17	14
023A-7	23	18.5	22	19	22	15	21	18
027A-7	27	22	26	23	26	18.5	25	22
035A-7	35	30	33	26	33	22	31	24
042A-7	42	37	40	35	40	30	38	33
049A-7	49	45	47	42	46	37	44	40
061A-7	61	55	58	49	49	45	47	46
084A-7	84	75	80	61	68	55	65	49
098A-7	98	90	93	84	83	75	79	68
119A-7	119	110	113	98	101	90	96	83
142A-7	126	110	120	119	112	90	106	90
174A-7	154	132	146	126	137	110	130	112
210A-7	184	160	175	154	161	132	153	137
271A-7	238	200	226	184	207	160	197	161

Definitions

$U_n$  Nominal voltage of the drive

$I_2$  Nominal output current (available continuously with no over-loading)

$P_n$  Typical motor power in no-overload use

$I_{Ld}$  Continuous rms output current allowing 10% overload for 1 minute every 5 minutes

$I_{Hd}$  Continuous rms output current allowing 50% overload for 1 minute every 5 minutes.

\* Continuous rms output current allowing 30% overload for 1 minute every 5 minutes.

\*\* Continuous rms output current allowing 25% overload for 1 minute every 5 minutes.

$P_{Hd}$  Typical motor power in heavy-duty use

The ratings apply at an ambient temperature of 40 °C (104 °F).

ACS880-01-...	Output ratings when selection "Low noise optimization" in parameter 97.09 Switching freq mode is enabled		
	Nominal use	Light-duty use	Heavy-duty use
	$I_2$	$I_{Ld}$	$I_{Hd}$
	A	A	A
$U_n = 230\text{ V}$			
04A6-2	4.1	3.9	3.3
06A6-2	5.9	5.6	4.1
07A5-2	6.7	6.4	5.9
10A6-2	9.5	9.0	6.7
16A8-2	15.0	14.3	9.5
24A3-2	22.0	20.9	15.0
031A-2	30.0	28.5	22.0
046A-2	41.0	39.0	30.0
061A-2	56	53	41
075A-2	56	53	47
087A-2	67	64	56
115A-2	94	89	67
145A-2	118	112	94
170A-2	146	139	118
206A-2	178	169	146
274A-2	216	205	178
$U_n = 400\text{ V}$			
02A4-3	2.2	2.1	1.7
03A3-3	3.0	2.9	2.2
04A0-3	3.6	3.4	3.0
05A6-3	5.0	4.8	3.6
07A2-3	6.5	6.2	5.0
09A4-3	8.5	8.1	6.5
12A6-3	11.3	10.7	8.5

ACS880-01-...	Output ratings when selection "Low noise optimization" in parameter 97.09 Switching freq mode is enabled		
	Nominal use	Light-duty use	Heavy-duty use
	$I_2$	$I_{Ld}$	$I_{Hd}$
	A	A	A
017A-3	15	14.3	11.3
025A-3	22	20.9	15.0
032A-3	30	29	22
038A-3	35	33	30
045A-3	41	39	35
061A-3	56	53	41
072A-3	56	53	47
087A-3	67	64	56
105A-3	86	82	67
145A-3	118	112	86
169A-3	146	139	118
206A-3	178	169	146
246A-3	194	184	178
293A-3	236	224	194*
363A-3	274	260	236
430A-3	325	309	274**
$U_n = 500\text{ V}$			
02A1-5	1.8	1.7	1.4
03A0-5	2.6	2.5	1.8
03A4-5	2.9	2.8	2.6
04A8-5	4.1	3.9	2.9
05A2-5	4.4	4.2	4.1
07A6-5	6.5	6.2	4.4
11A0-5	9.4	8.9	6.5
014A-5	12.0	11.4	9.4
021A-5	18.0	17.1	12.0
027A-5	23.0	21.9	18.0
034A-5	29	28	23
040A-5	29	28	23
052A-5	37	35	29
065A-5	39	37	33
077A-5	46	44	39
096A-5	72	68	46
124A-5	93	88	72
156A-5	133	126	93

ACS880-01-...	Output ratings when selection "Low noise optimization" in parameter 97.09 Switching freq mode is enabled		
	Nominal use	Light-duty use	Heavy-duty use
	$I_2$	$I_{Ld}$	$I_{Hd}$
	A	A	A
180A-5	153	145	133
240A-5	191	181	153
260A-5	206	196	191*
302A-5	206	196	191
361A-5	258	245	206
414A-5	296	281	258**
$U_n = 690 \text{ V}$			
07A4-7	7.0	6.7	5.6
09A9-7	9.4	8.9	7.0
14A3-7	13.6	12.9	9.4
019A-7	18	17	14
023A-7	22	21	18
027A-7	26	25	22
035A-7	33	31	24
042A-7	40	38	33
049A-7	46	44	40
061A-7	49	47	46
084A-7	68	65	49
098A-7	83	79	68
119A-7	101	96	83
142A-7	101	96	84
174A-7	122	116	101
210A-7	138	131	122
271A-7	178	169	138

### Definitions

$U_n$  Nominal voltage of the drive

$I_2$  Nominal output current (available continuously with no over-loading)

$P_n$  Typical motor power in no-overload use

$I_{Ld}$  Continuous rms output current allowing 10% overload for 1 minute every 5 minutes

$I_{Hd}$  Continuous rms output current allowing 50% overload for 1 minute every 5 minutes.

\* Continuous rms output current allowing 30% overload for 1 minute every 5 minutes.

\*\* Continuous rms output current allowing 25% overload for 1 minute every 5 minutes.

$P_{Hd}$  Typical motor power in heavy-duty use

The ratings apply at an ambient temperature of 40 °C (104 °F).



## High speed mode

Selection "High speed mode" of parameter 95.15 Special HW settings improves control performance at high output frequencies. ABB recommends it to be selected with output frequency of 120 Hz and above.

This table gives the drive ratings for the maximum output frequency when "High speed mode" in parameter 95.15 Special HW settings is enabled. With smaller output frequencies, the current derating is less. Contact ABB for operation above the recommended maximum output frequency or for the output current derating with output frequencies above 120 Hz and below the maximum output frequency.

At the 120 Hz output frequency: no derating.

ACS880-01-...	Output ratings with selection High speed mode of parameter 95.15 Special HW settings			
	Maximum output frequency			
	$f_{\max}$	Nominal use	Light-duty use	Heavy-duty use
		$I_2$	$I_{Ld}$	$I_{Hd}$
Hz	A	A	A	
$U_n = 230\text{ V}$				
04A6-2	500	4.1	3.9	3.3
06A6-2	500	5.9	5.6	4.1
07A5-2	500	6.7	6.4	5.9
10A6-2	500	9.5	9.0	6.7
16A8-2	500	15.0	14.3	9.5
24A3-2	500	22.0	20.9	15.0
031A-2	500	30.0	28.5	22.0
046A-2	500	41.0	39.0	30.0
061A-2	500	56	53	41
075A-2	500	56	53	47
087A-2	500	67	64	56
115A-2	500	84	80	67
145A-2	500	106	101	84
170A-2	500	135	128	106
206A-2	500	165	157	135
274A-2	500	189	180	165
$U_n = 400\text{ V}$				
02A4-3	500	2.2	2.1	1.7
03A3-3	500	3.0	2.9	2.2
04A0-3	500	3.6	3.4	3.0
05A6-3	500	5.0	4.8	3.6
07A2-3	500	6.5	6.2	5.0
09A4-3	500	8.5	8.1	6.5

## 206 Technical data

ACS880-01-...	Output ratings with selection High speed mode of parameter 95.15 Special HW settings			
	Maximum output frequency			
	$f_{\max}$	Nominal use	Light-duty use	Heavy-duty use
		$I_2$	$I_{Ld}$	$I_{Hd}$
Hz	A	A	A	
12A6-3	500	11.3	10.7	8.5
017A-3	500	15	14.3	11.3
025A-3	500	22	20.9	15.0
032A-3	500	30	29	22
038A-3	500	35	33	30
045A-3	500	41	39	35
061A-3	500	56	53	41
072A-3	500	56	53	47
087A-3	500	67	64	56
105A-3	500	77	73	67
145A-3	500	106	101	77
169A-3	500	135	128	106
206A-3	500	165	157	135
246A-3	500	170	162	143
293A-3	500	202	192	170*
363A-3	500	236	224	202
430A-3	500	280	266	236**
$U_n = 500\text{ V}$				
02A1-5	500	1.8	1.7	1.4
03A0-5	500	2.6	2.5	1.8
03A4-5	500	2.9	2.8	2.6
04A8-5	500	4.1	3.9	2.9
05A2-5	500	4.4	4.2	4.1
07A6-5	500	6.5	6.2	4.4
11A0-5	500	9.4	8.9	6.5
014A-5	500	12.0	11.4	9.4
021A-5	500	18.0	17.1	12.0
027A-5	500	23.0	21.9	18.0
034A-5	500	29	28	23
040A-5	500	29	28	23
052A-5	500	37	35	29
065A-5	500	39	37	33
077A-5	500	46	44	39
096A-5	500	58	55	46

ACS880-01-...	Output ratings with selection High speed mode of parameter 95.15 Special HW settings			
	Maximum output frequency			
	$f_{\max}$	Nominal use	Light-duty use	Heavy-duty use
		$I_2$	$I_{Ld}$	$I_{Hd}$
	Hz	A	A	A
124A-5	500	74	70	58
156A-5	500	122	116	74
180A-5	500	140	133	122
240A-5	500	168	160	140
260A-5	500	182	173	168*
302A-5	500	182	173	168
361A-5	500	206	196	182
414A-5	500	236	224	206**
$U_n = 690\text{ V}$				
07A4-7	500	6.7	6.4	5.4
09A9-7	500	8.9	8.5	6.7
14A3-7	500	12.9	12.3	8.9
019A-7	500	17	16	13
023A-7	500	21	20	17
027A-7	500	24	23	21
035A-7	500	32	30	23
042A-7	500	38	36	32
049A-7	500	44	42	38
061A-7	500	44	42	40
084A-7	500	53	50	44
098A-7	500	68	65	53
119A-7	500	83	79	68
142A-7	500	83	79	72
174A-7	500	96	91	83
210A-7	500	101	96	83
271A-7	500	130	124	101

## Definitions

- $f$  Output frequency  
 $f_{\max}$  Maximum output frequency with High speed mode  
 $U_n$  Nominal voltage of the drive  
 $I_2$  Continuous rms output current. No overload capability at 40 °C (104 °F)  
 $P_n$  Typical motor power in no-overload use  
 $I_{Ld}$  Continuous rms output current allowing 10% overload for 1 minute every 5 minutes

- $I_{Hd}$  Continuous rms output current allowing 50% overload for 1 minute every 5 minutes.
- \* Continuous rms output current allowing 30% overload for 1 minute every 5 minutes.
- \*\* Continuous rms output current allowing 25% overload for 1 minute every 5 minutes.

## Fuses (IEC)

gG and aR fuses for protection against short-circuit in the input power cable or drive are listed below. Either fuse type can be used for frames R1 to R9 if it operates rapidly enough. The operating time depends on the supply network impedance and the cross-sectional area and length of the supply cable.

For frames R7 to R9 ABB recommends ultra-rapid (aR) fuses, see section [Quick guide for selecting between gG and aR fuses \(page 218\)](#).

**Note 1:** See also section [Implementing short-circuit and thermal overload protection](#).

**Note 2:** Fuses with higher current rating than the recommended ones must not be used. Fuses with lower current rating can be used.

**Note 3:** For non-UL installations: Fuses from other manufacturers can be used if they meet the ratings and the melting curve of the fuse does not exceed the melting curve of the fuse mentioned in the table.

### ■ aR fuses DIN 43653 stud-mount (frames R1 to R9)

ABB recommends stud-mount fuses for better cooling but blade style fuses can be used as well.

Ultrarapid (aR) fuses stud-mount (one fuse per phase)							
ACS880-01-...	Min. short-circuit current <sup>1)</sup> (A)	Input current (A)	Fuse				
			A	A <sup>2</sup> s	V	Busmann type	Type DIN 43653
$U_n = 230\text{ V}$							
04A6-2	40	4.6	16	48	690	170M1309	000
06A6-2	40	6.6	16	48	690	170M1309	000
07A5-2	40	7.5	16	48	690	170M1309	000
10A6-2	53	10.6	16	48	690	170M1309	000
16A8-2	65	16.8	25	130	690	170M1311	000
24A3-2	120	24.3	40	460	690	170M1313	000
031A-2	160	31.0	63	1450	690	170M1315	000
046A-2	280	46	80	2550	690	170M1316	000

<sup>1)</sup> minimum short-circuit current of the installation

Ultrarapid (aR) fuses stud-mount (one fuse per phase)							
ACS880-01-...	Min. short-circuit current <sup>1)</sup> (A)	Input current (A)	Fuse				
			A	A <sup>2</sup> s	V	Bussmann type	Type DIN 43653
061A-2	300	61	125	8500	690	170M1318	000
075A-2	380	75	125	7500	690	170M3013	1
087A-2	500	87	160	8500	690	170M3014	1
115A-2	700	115	200	15000	690	170M3015	1
145A-2	1000	145	250	28500	690	170M3016	1
170A-2	1280	170	315	46500	690	170M3017	1
206A-2	1450	206	350	68500	690	170M3018	1
274A-2	2050	274	400	105000	690	170M3019	1
<b><math>U_n = 400\text{ V}</math></b>							
02A4-3	65	2.4	25	130	690	170M1311	000
03A3-3	65	3.3	25	130	690	170M1311	000
04A0-3	65	4.0	25	130	690	170M1311	000
05A6-3	65	5.6	25	130	690	170M1311	000
07A2-3	65	8.0	25	130	690	170M1311	000
09A4-3	65	10.0	25	130	690	170M1311	000
12A6-3	65	12.9	25	130	690	170M1311	000
017A-3	120	17	40	460	690	170M1313	000
025A-3	120	25	40	460	690	170M1313	000
032A-3	170	32	63	1450	690	170M1315	000
038A-3	170	38	63	1450	690	170M1315	000
045A-3	280	45	80	2550	690	170M1316	000
061A-3	380	61	100	4650	690	170M1317	000
072A-3	480	72	125	8500	690	170M1318	000
087A-3	700	87	160	16000	690	170M1319	000
105A-3	1280	105	200	15000	690	170M3015	1
145A-3	1280	145	250	28500	690	170M3016	1

<sup>1)</sup> minimum short-circuit current of the installation

Ultrarapid (aR) fuses stud-mount (one fuse per phase)							
ACS880-01-...	Min. short-circuit current <sup>1)</sup> (A)	Input current (A)	Fuse				
			A	A <sup>2</sup> s	V	Bussmann type	Type DIN 43653
169A-3	1800	169	315	46500	690	170M3017	1
206A-3	2210	206	350	68500	690	170M3018	1
246A-3	3010	246	450	105000	690	170M5009	2
293A-3	4000	293	500	145000	690	170M5010	2
363A-3	5550	363	630	275000	690	170M5012	2
430A-3	7800	430	700	405000	690	170M5013	2
$U_n = 500 \text{ V}$							
02A1-5	65	2.1	25	130	690	170M1308	000
03A0-5	65	3.0	25	130	690	170M1308	000
03A4-5	65	3.4	25	130	690	170M1308	000
04A8-5	65	4.8	25	130	690	170M1308	000
05A2-5	65	5.2	25	130	690	170M1308	000
07A6-5	65	7.6	25	130	690	170M1308	000
11A0-5	65	11.0	25	130	690	170M1308	000
014A-5	120	14	40	460	690	170M1313	000
021A-5	120	21	40	460	690	170M1313	000
027A-5	170	27	63	1450	690	170M1315	000
034A-5	170	34	63	1450	690	170M1315	000
040A-5	280	40	80	2550	690	170M1316	000
052A-5	300	52	100	4650	690	170M1317	000
065A-5	480	65	125	8500	690	170M1318	000
077A-5	700	77	160	16000	690	170M1319	000
096A-5	1000	96	200	15000	690	170M3015	1
124A-5	1280	124	250	28500	690	170M3016	1
156A-5	1610	156	315	46500	690	170M3017	1
180A-5	2210	180	315	46500	690	170M3018	1

<sup>1)</sup> minimum short-circuit current of the installation

Ultrarapid (aR) fuses stud-mount (one fuse per phase)							
ACS880-01-...	Min. short-circuit current 1) (A)	Input current (A)	Fuse				
			A	A <sup>2</sup> s	V	Bussmann type	Type DIN 43653
240A-5	2620	240	400	74000	690	170M5008	2
260A-5	4000	260	450	105000	690	170M5009	2
302A-5	5550	302	550	190000	690	170M5011	2
361A-5	5550	361	630	275000	690	170M5012	2
414A-5	7800	414	700	405000	690	170M5013	2
$U_n = 690 \text{ V}$							
07A4-7	40	7.4	16	48	690	170M1309	000
09A9-7	53	9.9	20	78	690	170M1310	000
14A3-7	94	14.3	32	270	690	170M1312	000
019A-7	120	19	40	460	690	170M1313	000
023A-7	160	23	50	770	690	170M1314	000
027A-7	160	27	50	770	690	170M1314	000
035A-7	170	35	63	1450	690	170M1315	000
042A-7	280	42	80	2550	690	170M1316	000
049A-7	280	49	80	2550	690	170M1316	000
061A-7	480	61	125	8500	690	170M1318	000
084A-7	700	84	160	16000	690	170M1319	000
098A-7	1610	98	200	15000	690	170M3015	1
119A-7	1610	119	200	15000	690	170M3015	1
142A-7	2210	142	250	28500	690	170M3016	1
174A-7	2210	174	315	46500	690	170M3017	1
210A-7	3200	210	400	74000	690	170M5008	2
271A-7	3200	271	450	105000	690	170M5009	2

1) minimum short-circuit current of the installation

## ■ aR fuses DIN 43620 blade style (frames R1 to R9)

Ultrarapid (aR) fuses blade style (one fuse per phase)							
ACS880-01-...	Min. short-circuit current <sup>1)</sup> (A)	Input current (A)	Fuse				
			A	A <sup>2</sup> s	V	Bussmann type	Type DIN 43620
$U_n = 230 \text{ V}$							
04A6-2	40	4.6	16	48	690	170M1559	000
06A6-2	40	6.6	16	48	690	170M1559	000
07A5-2	40	7.5	16	48	690	170M1559	000
10A6-2	53	10.6	20	78	690	170M1560	000
16A8-2	65	16.8	25	130	690	170M1561	000
24A3-2	120	24.3	40	460	690	170M1563	000
031A-2	160	31.0	63	1450	690	170M1565	000
046A-2	280	46	80	2550	690	170M1566	000
061A-2	300	61	125	8500	690	170M1568	000
075A-2	380	75	200	15000	690	170M3815	1
087A-2	500	87	250	28500	690	170M3816	1
115A-2	700	115	315	46500	690	170M3817	1
145A-2	1000	145	315	46500	690	170M3817	1
170A-2	1280	170	450	105000	690	170M5809	2
206A-2	1450	206	500	155000	690	170M5810	2
274A-2	2050	274	630	220000	690	170M5810	3
$U_n = 400 \text{ V}$							
02A4-3	65	2.4	25	130	690	170M1561	000
03A3-3	65	3.3	25	130	690	170M1561	000
04A0-3	65	4.0	25	130	690	170M1561	000
05A6-3	65	5.6	25	130	690	170M1561	000
07A2-3	65	8.0	25	130	690	170M1561	000
09A4-3	65	10.0	25	130	690	170M1561	000
12A6-3	65	12.9	25	130	690	170M1561	000
017A-3	120	17	40	460	690	170M1563	000
<sup>1)</sup> minimum short-circuit current of the installation							



Ultrarapid (aR) fuses blade style (one fuse per phase)							
ACS880-01-...	Min. short-circuit current <sup>1)</sup> (A)	Input current (A)	Fuse				
			A	A <sup>2</sup> <sub>s</sub>	V	Bussmann type	Type DIN 43620
025A-3	120	25	40	460	690	170M1563	000
032A-3	170	32	63	1450	690	170M1565	000
038A-3	170	38	63	1450	690	170M1565	000
045A-3	280	45	80	2550	690	170M1566	000
061A-3	380	61	100	4650	690	170M1567	000
072A-3	480	72	125	8500	690	170M1568	000
087A-3	700	87	160	16000	690	170M1569	000
105A-3	1280	105	315	46500	690	170M3817	1
145A-3	1280	145	315	46500	690	170M3817	1
169A-3	1800	169	450	105000	690	170M5809	2
206A-3	2210	206	500	145000	690	170M5810	2
246A-3	3010	246	630	275000	690	170M5812	2
293A-3	4000	293	800	490000	690	170M6812D	3
363A-3	5550	363	1000	985000	690	170M6814D	3
430A-3	7800	430	1250	2150000	690	170M8554D	3
<b>U<sub>n</sub> = 500 V</b>							
02A1-5	65	2.1	25	130	690	170M1561	000
03A0-5	65	3.0	25	130	690	170M1561	000
03A4-5	65	3.4	25	130	690	170M1561	000
04A8-5	65	4.8	25	130	690	170M1561	000
05A2-5	65	5.2	25	130	690	170M1561	000
07A6-5	65	7.6	25	130	690	170M1561	000
11A0-5	65	11.0	25	130	690	170M1561	000
014A-5	120	14	40	460	690	170M1563	000
021A-5	120	21	40	460	690	170M1563	000
027A-5	170	27	63	1450	690	170M1565	000
034A-5	170	34	63	1450	690	170M1565	000

<sup>1)</sup> minimum short-circuit current of the installation

Ultrarapid (aR) fuses blade style (one fuse per phase)							
ACS880-01-...	Min. short-circuit current <sup>1)</sup> (A)	Input current (A)	Fuse				
			A	A <sup>2</sup> s	V	Bussmann type	Type DIN 43620
040A-5	280	40	80	2550	690	170M1566	000
052A-5	300	52	100	4650	690	170M1567	000
065A-5	480	65	125	8500	690	170M1568	000
077A-5	700	77	160	16000	690	170M1569	000
096A-5	1000	96	250	28500	690	170M3816	1
124A-5	1280	124	315	46500	690	170M3817	1
156A-5	1610	156	400	74000	690	170M5808	2
180A-5	2210	180	500	155000	690	170M5810	2
240A-5	2620	240	550	190000	690	170M5811	2
260A-5	4000	260	800	490000	690	170M6812D	3
302A-5	5550	302	1000	985000	690	170M6814D	3
361A-5	5550	361	1000	985000	690	170M6814D	3
414A-5	7800	414	1250	2150000	690	170M8554D	3
$U_n = 690 \text{ V}$							
07A4-7	40	7.4	16	48	690	170M1559	000
09A9-7	53	9.9	20	78	690	170M1560	000
14A3-7	94	14.3	32	270	690	170M1562	000
019A-7	120	19	40	460	690	170M1563	000
023A-7	160	23	50	770	690	170M1564	000
027A-7	160	27	50	770	690	170M1564	000
035A-7	170	35	63	1450	690	170M1565	000
042A-7	280	42	80	2550	690	170M1566	000
049A-7	280	49	80	2550	690	170M1566	000
061A-7	480	61	125	8500	690	170M1568	000
084A-7	700	84	160	16000	690	170M1569	000
098A-7	1610	98	400	74000	690	170M3816	2
119A-7	1610	119	400	74000	690	170M3816	2

<sup>1)</sup> minimum short-circuit current of the installation

Ultrarapid (aR) fuses blade style (one fuse per phase)							
ACS880-01-...	Min. short-circuit current <sup>1)</sup> (A)	Input current (A)	Fuse				
			A	A <sup>2</sup> <sub>s</sub>	V	Bussmann type	Type DIN 43620
142A-7	2210	142	500	145000	690	170M5810	2
174A-7	2210	174	500	145000	690	170M5810	2
210A-7	3200	210	700	320000	690	170M6811D	3
271A-7	3200	271	700	320000	690	170M6811D	3

<sup>1)</sup> minimum short-circuit current of the installation

### ■ gG fuses DIN 43620 blade style (frames R1 to R9)

Check on the fuse time-current curve to ensure the operating time of the fuse is below 0.5 seconds. Obey the local regulations.

gG fuses (one fuse per phase)							
ACS880-01-...	Min. short-circuit current <sup>1)</sup>	Input current	Fuse				
			A	A	A	A <sup>2</sup> <sub>s</sub>	V
$U_n = 230 \text{ V}$							
04A6-2	40	4.6	6	110	500	OFAF000H6	000
06A6-2	80	6.6	10	360	500	OFAF000H10	000
07A5-2	120	7.5	16	740	500	OFAF000H16	000
10A6-2	120	10.6	16	740	500	OFAF000H16	000
16A8-2	200	16.8	25	2500	500	OFAF000H25	000
24A3-2	350	24.3	40	7700	500	OFAF000H40	000
031A-2	400	31.0	50	16000	500	OFAF000H50	000
046A-2	500	46	63	20100	500	OFAF000H63	000
061A-2	800	61	80	37500	500	OFAF000H80	000
075A-2	1000	75	100	65000	500	OFAF000H100	000
087A-2	1300	87	125	100000	500	OFAF000H125	00
115A-2	1700	115	160	170000	500	OFAF000H160	00
145A-2	2300	145	200	300000	500	OFAF000H200	0
170A-2	3300	170	250	600000	500	OFAF000H250	0

<sup>1)</sup> minimum short-circuit current of the installation

gG fuses (one fuse per phase)							
ACS880-01-...	Min. short-circuit current <sup>1)</sup>	Input current	Fuse				
			A	A	A	A <sup>2</sup> s	V
206A-2	5500	206	315	710000	500	OFAF1H315	1
274A-2	7000	274	400	1100000	500	OFAF2H400	2
$U_n = 400 \text{ V}$							
02A4-3	17	2.4	4	53	500	OFAF000H4	000
03A3-3	40	3.3	6	110	500	OFAF000H6	000
04A0-3	40	4.0	6	110	500	OFAF000H6	000
05A6-3	80	5.6	10	355	500	OFAF000H10	000
07A2-3	80	8.0	10	355	500	OFAF000H10	000
09A4-3	120	10.0	16	700	500	OFAF000H16	000
12A6-3	120	12.9	16	700	500	OFAF000H16	000
017A-3	200	17	25	2500	500	OFAF000H25	000
025A-3	250	25	32	4500	500	OFAF000H32	000
032A-3	350	32	40	7700	500	OFAF000H40	000
038A-3	400	38	50	15400	500	OFAF000H50	000
045A-3	500	45	63	21300	500	OFAF000H63	000
061A-3	800	61	80	37000	500	OFAF000H80	000
072A-3	1000	72	100	63600	500	OFAF000H100	000
087A-3	1000	87	100	63600	500	OFAF000H100	000
105A-3	1300	105	125	103000	500	OFAF000H125	00
145A-3	1700	145	160	185000	500	OFAF000H160	00
169A-3	3300	169	250	600000	500	OFAF0H250	0
206A-3	5500	206	315	710000	500	OFAF1H315	1
246A-3	6400	246	355	920000	500	OFAF1H355	1
293A-3	7800	293	425	1300000	500	OFAF2H425	2
363A-3	9400	363	500	2000000	500	OFAF2H500	2

<sup>1)</sup> minimum short-circuit current of the installation

gG fuses (one fuse per phase)							
ACS880-01-...	Min. short-circuit current <sup>1)</sup>	Input current	Fuse				
	A	A	A	A <sup>2</sup> <sub>s</sub>	V	ABB type	DIN size
430A-3	10200	430	630	2800000	500	OFAF3H630	3
<i>U<sub>n</sub> = 500 V</i>							
02A1-5	17	2.1	4	53	500	OFAF000H4	000
03A0-5	40	3.0	6	110	500	OFAF000H6	000
03A4-5	40	3.4	6	110	500	OFAF000H6	000
04A8-5	80	4.8	10	355	500	OFAF000H10	000
05A2-5	80	5.2	10	355	500	OFAF000H10	000
07A6-5	120	7.6	16	700	500	OFAF000H16	000
11A0-5	120	11.0	16	700	500	OFAF000H16	000
014A-5	200	14	25	2500	500	OFAF000H25	000
021A-5	250	21	32	4500	500	OFAF000H32	000
027A-5	350	27	40	7700	500	OFAF000H40	000
034A-5	400	34	50	15400	500	OFAF000H50	000
040A-5	500	40	63	21300	500	OFAF000H63	000
052A-5	800	52	80	37000	500	OFAF000H80	000
065A-5	1000	65	100	63600	500	OFAF000H100	000
077A-5	1000	77	100	63600	500	OFAF000H100	000
096A-5	1300	96	125	103000	500	OFAF000H125	00
124A-5	1700	124	160	185000	500	OFAF000H160	00
156A-5	3300	156	250	600000	500	OFAF000H250	0
180A-5	5500	180	315	710000	500	OFAF1H315	1
240A-5	6400	240	355	920000	500	OFAF1H355	1
260A-5	7000	260	400	1100000	500	OFAF2H400	2
302A-5	9400	302	500	2000000	500	OFAF2H500	2
361A-5	10200	361	630	2800000	500	OFAF3H630	3

<sup>1)</sup> minimum short-circuit current of the installation

gG fuses (one fuse per phase)							
ACS880-01-...	Min. short-circuit current <sup>1)</sup>	Input current	Fuse				
			A	A	A	A <sup>2</sup> s	V
414A-5	10200	414	630	2800000	500	OFAF3H630	3
$U_n = 690 \text{ V}$							
07A4-7	115	7.4	16	1200	690	OFAA000GG16	000
09A9-7	145	9.9	20	2400	690	OFAA000GG20	000
14A3-7	190	14.3	25	4000	690	OFAA000GG25	000
019A-7	280	19	35	12000	690	OFAA000GG35	000
023A-7	450	23	50	24000	690	OFAA000GG50	000
027A-7	450	27	50	24000	690	OFAA000GG50	000
035A-7	520	35	63	30000	690	OFAA000GG63	000
042A-7	800	42	80	51000	690	OFAA0GG80	0
049A-7	800	49	80	51000	690	OFAA0GG80	0
061A-7	1050	61	100	95000	690	OFAA0GG100	0
084A-7	1700	84	160	240000	690	OFAA1GG160	1
098A-7	1700	98	160	240000	690	OFAA1GG160	1
119A-7	2200	119	200	350000	690	OFAA1GG200	1
142A-7	3200	142	250	700000	690	OFAA1GG250	1
174A-7	5500	174	315	850000	690	OFAA2GG315	2
210A-7	7000	210	400	1300000	690	OFAA3GG400	3
271A-7	7000	271	400	1300000	690	OFAA3GG400	3
<sup>1)</sup> minimum short-circuit current of the installation							

### ■ Quick guide for selecting between gG and aR fuses

The combinations (cable size, cable length, transformer size and fuse type) in this table fulfill the minimum requirements for the proper operation of the fuse. Use this table to select between gG and aR fuses or to calculate the short-circuit current

of the installation as described in Calculating the short-circuit current of the installation (page 221).

ACS880-01-...	Cable type		Supply transformer minimum apparent power $S_N$ (kVA)					
	Copper	Aluminum	Maximum cable length with gG fuses			Maximum cable length with aR fuses		
	mm <sup>2</sup>	mm <sup>2</sup>	10 m	50 m	100 m	10 m	100 m	200 m
$U_n = 230$ V								
04A6-2	3×1.5	-	1.1	1.1	-	1.1	1.2	-
06A6-2	3×1.5	-	2.2	2.4	-	1.1	1.2	-
07A5-2	3×1.5	-	3.3	4.3	-	1.1	1.2	-
10A6-2	3×1.5	-	3.3	4.3	-	1.5	1.8	-
16A8-2	3×6	-	5.5	5.8	-	1.8	1.8	-
24A3-2	3×6	-	9.7	11	-	3.3	3.5	-
031A-2	3×10	-	11	12	-	4.4	4.6	-
046A-2	3×16	3×35	14	15	-	7.7	8.2	-
061A-2	3×25	3×35	22	24	-	8.3	8.6	-
075A-2	3×35	3×50	28	29	-	11	11	-
087A-2	3×35	3×70	36	39	-	14	15	-
115A-2	3×50	3×70	48	52	-	19	21	-
145A-2	3×95	3×120	64	70	-	28	30	-
170A-2	3×120	3×150	93	104	-	36	39	-
206A-2	3×150	3×240	158	194	-	40	45	-
274A-2	2×(3×95)	2×(3×120)	198	229	-	57	62	-
$U_n = 400$ V								
02A4-3	3×1.5	-	0.82	0.82	0.82	3.1	3.4	5.0
03A3-3	3×1.5	-	1.9	1.9	2.0	3.1	3.4	5.0
04A0-3	3×1.5	-	1.9	1.9	2.0	3.1	3.4	5.0
05A6-3	3×1.5	-	3.8	4.0	4.4	3.1	3.4	5.0
07A2-3	3×1.5	-	3.8	4.0	4.4	3.1	3.4	5.0
09A4-3	3×1.5	-	5.8	6.2	8.4	3.1	3.4	5.0
12A6-3	3×1.5	-	5.8	6.2	8.4	3.1	3.4	5.0
017A-3	3×6	-	9.6	9.8	10	5.8	5.9	6.2
025A-3	3×6	-	12	12	13	5.8	5.9	6.2
032A-3	3×10	-	17	17	18	8.2	8.3	8.7
038A-3	3×10	-	19	20	21	8.2	8.3	8.7
045A-3	3×16	3×25	24	24	26	13	14	15
061A-3	3×25	3×25	39	39	42	18	19	20
072A-3	3×35	3×35	48	49	52	23	24	25
087A-3	3×35	3×50	48	49	52	34	35	38
105A-3	3×50	3×70	63	65	68	62	67	80

## 220 Technical data

ACS880-01-...	Cable type		Supply transformer minimum apparent power $S_N$ (kVA)					
	Copper	Aluminum	Maximum cable length with gG fuses			Maximum cable length with aR fuses		
	mm <sup>2</sup>	mm <sup>2</sup>	10 m	50 m	100 m	10 m	100 m	200 m
145A-3	3×95	3×95	82	85	88	62	65	70
169A-3	3×120	3×150	160	170	187	87	93	104
206A-3	3×150	3×185	269	298	357	107	116	132
246A-3	2×(3×70)	2×(3×95)	311	335	393	145	157	180
293A-3	2×(3×95)	2×(3×120)	380	411	478	193	211	248
363A-3	2×(3×120)	2×(3×185)	459	502	591	269	304	378
430A-3	2×(3×150)	2×(3×240)	499	547	641	380	452	634
$U_n = 500$ V								
02A1-5	3×1.5	-	1.0	1.0	1.0	3.9	4.1	5.0
03A0-5	3×1.5	-	2.4	2.4	2.4	3.9	4.1	5.0
03A4-5	3×1.5	-	2.4	2.4	2.4	3.9	4.1	5.0
04A8-5	3×1.5	-	4.8	4.9	5.2	3.9	4.1	5.0
05A2-5	3×1.5	-	4.8	4.9	5.2	3.9	4.1	5.0
07A6-5	3×1.5	-	7.2	7.5	8.9	3.9	4.1	5.0
11A0-5	3×1.5	-	7.2	7.5	8.9	3.9	4.1	5.0
014A-5	3×6	-	12	12	12	7.2	7.3	7.6
021A-5	3×6	-	15	15	16	7.2	7.3	7.6
027A-5	3×10	-	21	21	22	10	10	11
034A-5	3×10	-	24	24	25	10	10	11
040A-5	3×16	3×35	30	30	31	17	17	18
052A-5	3×25	3×35	48	49	51	18	18	19
065A-5	3×35	3×50	60	61	63	29	29	30
077A-5	3×35	3×70	60	61	63	42	43	46
096A-5	3×50	3×70	78	80	83	60	63	67
124A-5	3×95	3×120	103	105	108	77	80	85
156A-5	3×120	3×150	200	209	224	97	102	109
180A-5	3×150	3×240	335	362	411	133	143	156
240A-5	2×(3×70)	2×(3×95)	388	410	456	158	165	179
260A-5	2×(3×70)	2×(3×95)	425	452	512	242	262	307
302A-5	2×(3×95)	2×(3×120)	572	617	711	336	372	450
361A-5	2×(3×120)	2×(3×185)	621	669	763	336	368	427
414A-5	2×(3×150)	2×(3×240)	621	666	747	473	539	674
$U_n = 690$ V								
07A4-7	3×1.5	-	9.5	9.5	9.5	3.3	3.3	3.3
09A9-7	3×1.5	-	12	12	12	4.4	4.4	4.4
14A3-7	3×2.5	-	16	16	16	7.8	7.8	7.8
019A-7	3×4	-	23	23	23	9.9	10	10



ACS880-01-...	Cable type		Supply transformer minimum apparent power $S_N$ (kVA)					
	Copper	Aluminum	Maximum cable length with gG fuses			Maximum cable length with aR fuses		
	mm <sup>2</sup>	mm <sup>2</sup>	10 m	50 m	100 m	10 m	100 m	200 m
023A-7	3×6	-	37	37	38	13	13	13
027A-7	3×10	-	37	37	38	13	13	13
035A-7	3×10	3×25	43	43	44	14	14	14
042A-7	3×16	3×25	66	67	68	23	23	24
049A-7	3×16	3×25	66	67	68	23	23	24
061A-7	3×25	3×35	87	88	90	40	40	41
084A-7	3×35	3×50	141	144	149	58	59	61
098A-7	3×50	3×70	141	143	146	134	138	145
119A-7	3×70	3×95	183	187	192	134	138	145
142A-7	3×95	3×120	267	275	286	184	192	205
174A-7	3×120	3×185	452	476	515	184	192	205
210A-7	3×185	2×(3×95)	584	608	654	266	277	295
271A-7	3×240	2×(3×120)	584	605	640	266	275	289

### ■ Calculating the short-circuit current of the installation

Make sure that the short-circuit current of the installation is at least the value given in the fuse table.

The short-circuit current of the installation can be calculated as follows:

$$I_{k2-ph} = \frac{U}{2 \cdot \sqrt{R_c^2 + (Z_k + X_c)^2}}$$

where

$I_{k2-ph}$	Short-circuit current in symmetrical two-phase short-circuit
$U$	Network line-to-line voltage (V)
$R_c$	Cable resistance (ohm)
$Z_k$	$Z_k = z_k \cdot U_N^2 / S_N =$ transformer impedance (ohm)
$z_k$	Transformer impedance (%)
$U_N$	Transformer rated voltage (V)
$S_N$	Nominal apparent power of the transformer (kVA)
$X_c$	Cable reactance (ohm)

### Calculation example

Drive:

## 222 Technical data

- ACS880-01-145A-3
- Supply voltage = 410 V

Transformer:

- rated power  $S_n = 600$  kVA
- rated voltage (drive supply voltage)  $U_N = 430$  V
- transformer impedance  $z_k = 7.2\%$ .

Supply cable:

- length = 170 m
- resistance/length = 0.398 ohm/km
- reactance/length = 0.082 ohm/km.

$$Z_k = z_k \cdot \frac{U_N^2}{S_N} = 0.072 \cdot \frac{(430 \text{ V})^2}{600 \text{ kVA}} = 22.19 \text{ mohm}$$

$$R_c = 170 \text{ m} \cdot 0.398 \frac{\text{ohm}}{\text{km}} = 67.66 \text{ mohm}$$

$$X_c = 170 \text{ m} \cdot 0.082 \frac{\text{ohm}}{\text{km}} = 13.94 \text{ mohm}$$

$$I_{k2\text{-ph}} = \frac{410 \text{ V}}{2 \cdot \sqrt{(67.66 \text{ mohm})^2 + (22.19 \text{ mohm} + 13.94 \text{ mohm})^2}} = 2.7 \text{ kA}$$

The calculated short-circuit current 2.7 kA is higher than the minimum short-circuit current of the drive gG fuse type OFAF00H160 (1700 A). -> The 500 V gG fuse (ABB Control OFAF00H160) can be used.

---

## Fuses (UL)

The UL Listed fuses in this manual are required for branch circuit protection and required per NEC. The drives are suitable for use on a circuit capable of delivering not more than 100 kA symmetrical amperes (rms) at 240 V, 480 V, and 600 V maximum when protected by the fuses described below.

Class T fuses are recommended below. Also allowed are UL Listed 248-8 Class J fast acting, time delay, and high speed fuses, 248-4 Class CC fast acting fuses and 248-17 Class CF fast acting and time delay fuses of the same nominal voltage and current rating.

Refer to notes below the tables.

ACS880-01-...	Input current	UL (one fuse per phase)			
	A	A	V	Bussmann type	UL class
$U_n = 230\text{ V}$					
04A6-2	4.4	15	600	JJS-15	T
06A6-2	6.3	15	600	JJS-15	T
07A5-2	7.1	15	600	JJS-15	T
10A6-2	10.1	20	600	JJS-20	T
16A8-2	16.0	25	600	JJS-25	T
24A3-2	23.1	35	600	JJS-35	T
031A-2	29.3	50	600	JJS-50	T
046A-2	44	80	600	JJS-80	T
061A-2	58	80	600	JJS-80	T
075A-2	71	110	600	JJS-110	T
087A-2	83	110	600	JJS-110	T
115A-2	109	150	600	JJS-150	T
145A-2	138	200	600	JJS-200	T
170A-2	162	250	600	JJS-250	T
206A-2	196	300	600	JJS-300	T
274A-2	260	400	600	JJS-400	T
$U_n = 480\text{ V}$					
02A1-5	2.1	15	600	JJS-15	T
03A0-5	3.0	15	600	JJS-15	T
03A4-5	3.4	15	600	JJS-15	T
04A8-5	4.8	15	600	JJS-15	T
05A2-5	5.2	15	600	JJS-15	T
07A6-5	7.6	15	600	JJS-15	T
11A0-5	11	20	600	JJS-20	T
014A-5	14	25	600	JJS-25	T
021A-5	21	35	600	JJS-35	T

ACS880-01-...	Input current	UL (one fuse per phase)			
	A	A	V	Bussmann type	UL class
027A-5	27	40	600	JJS-40	T
034A-5	34	50	600	JJS-50	T
040A-5	40	60	600	JJS-60	T
052A-5	52	80	600	JJS-80	T
065A-5	65	90	600	JJS-90	T
077A-5	77	110	600	JJS-110	T
096A-5	96	150	600	JJS-150	T
124A-5	124	200	600	JJS-200	T
156A-5	156	225	600	JJS-225	T
180A-5	180	300	600	JJS-300	T
240A-5	240	350	600	JJS-350	T
260A-5	260	400	600	JJS-400	T
302A-5	302	400	600	JJS-400	T
361A-5	361	500	600	JJS-500	T
414A-5	414	600	600	JJS-600	T
$U_n = 575 \text{ V}$					
07A4-7	7.0	15	600	JJS-15	T
09A9-7	9.4	20	600	JJS-20	T
14A3-7	13.6	30	600	JJS-30	T
019A-7	18	40	600	JJS-40	T
023A-7	22	50	600	JJS-50	T
027A-7	27	50	600	JJS-50	T
035A-7	41	60	600	JJS-60	T
042A-7	52	80	600	JJS-80	T
049A-7	52	80	600	JJS-80	T
061A-7	62	110	600	JJS-110	T
084A-7	77	150	600	JJS-150	T
098A-7	99	150	600	JJS-150	T
119A-7	125	200	600	JJS-200	T
142A-7	144	250	600	JJS-250	T
174A-7	180	300	600	JJS-300	T
210A-7	242	400	600	JJS-400	T
271A-7	271	400	600	JJS-400	T

Semiconductor fuses for frame R9 with base part numbers are listed below. Semiconductor fuses with optional indicators can be used and have no impact on the drive UL listing, performance, or rating of the fuse. For 100 kA SCCR panel rating the semiconductor fuses must be in the same enclosure as the drive.

ACS880-01-...	Input current	UL fuse size (A) and voltage (V)		Bussmann semiconductor fuses UL 248-13 Recognized Fuses			
	A	Maximum current (A)	Voltage rating (V)	Type Flush End	Type DIN 43463	Type US Style	Type French Style
$U_n = 480 \text{ V}$							
302A-5	302	550	690	170M6409	170M6009	170M6609	170M6309
361A-5	361	630	690	170M6410	170M6010	170M6610	170M6310
414A-5	414	700	690	170M6411	170M6011	170M6611	170M6311
$U_n = 575 \text{ V}$							
210A-7	242	500	690	170M6408	170M6008	170M6608	170M6308
271A-7	271	500	690	170M6408	170M6008	170M6608	170M6308

- Fuses are required as part of the installation, are not included in the base drive configuration and must be provided by others.
- Fuses with a higher current rating than specified must not be used.
- The UL listed fuses recommended by ABB are the required branch circuit protection per NEC. Circuit breakers listed in section Circuit breakers (UL) are also acceptable as branch circuit protection.
- The recommended size or smaller UL listed 248 fast acting, time delay, or high speed fuses must be used to maintain the UL listing of the drive. Additional protection can be used. Refer to local codes and regulations.
- A fuse of a different class can be used at the high fault rating where the  $I_{peak}$  and  $I^2t$  of the new fuse is not greater than that of the specified fuse.
- UL listed 248 fast acting, time delay, or high speed fuses from other manufacturers can be used if they meet the same class and rating requirements specified in the rules above.
- When installing a drive, always follow ABB installation instructions, NEC requirements and local codes.
- Only 480 V R9 drives with serial numbers beginning 1204205581 when built in Finland and beginning 22106xxxxx when built in the U.S. may be protected with fuses other than Class T fuses.
- Alternative fuses can be used if they meet certain characteristics. For acceptable fuses, see the manual supplement ([3AXD50000645015](#)).

In multicable installations, install only one fuse per phase (not one fuse per conductor). See also section Implementing short-circuit and thermal overload protection (page 82)

## Circuit breakers (IEC)

### ■ ABB miniature and molded case circuit breakers

The table below lists the circuit breakers that can be used with the drive.

ACS880-01-...	Frame	ABB miniature circuit breaker		ABB moulded case circuit breaker (Tmax)	
		Type	kA <sup>1)</sup>	Type	kA <sup>1)</sup>
$U_n = 230\text{ V}$					
04A6-2	R1	S 203 M/P-B/C 10	5	-	-
06A6-2	R1	S 203 M/P-B/C 10	5	-	-
07A5-2	R1	S 203 M/P-B/C 16	5	-	-
10A6-2	R1	S 203 M/P-B/C 16	5	-	-
16A8-2	R2	S 203 M/P-B/C 20	5	-	-
24A3-2	R2	S 203 M/P-B/C 32	5	-	-
031A-2	R3	S 203 M/P-B/C 50	5	-	-
046A-2	R4	S 803 S-B/C 75	10	-	-
061A-2	R4	S 803 S-B/C 80	10	-	-
075A-2	R5	S 803 S-B/C 125	10	XT2 L 160 Ekip LS/I In=160 3p F F	65
087A-2	R5	S 803 S-B/C 125	10	XT2 L 160 Ekip LS/I In=160 3p F F	65
115A-2	R6	-	-	XT2 L 160 Ekip LS/I In=160 3p F F	65
145A-2	R6	-	-	XT4 L 250 Ekip LS/I In=250 3p F F	65
170A-2	R7	-	-	XT4 L 250 Ekip LS/I In=250 3p F F	65
206A-2	R7	-	-	T4 L 320 PR221DS-LS/I In=320 3p F F	65
274A-2	R8	-	-	T4 L 320 PR221DS-LS/I In=320 3p F F	65
$U_n = 400\text{ V}$					
02A4-3	R1	S 203 M/P-B/C 6	5	-	-
03A3-3	R1	S 203 M/P-B/C 6	5	-	-
04A0-3	R1	S 203 M/P-B/C 6	5	-	-
05A6-3	R1	S 203 M/P-B/C 10	5	-	-
07A2-3	R1	S 203 M/P-B/C 13	5	-	-
09A4-3	R1	S 203 M/P-B/C 13	5	-	-
12A6-3	R1	S 203 M/P-B/C 20	5	-	-
017A-3	R2	S 203 M/P-B/C 25	5	-	-
025A-3	R2	S 203 M/P-B/C 32	5	-	-
032A-3	R3	S 203 M/P-B/C 50	5	-	-
t <sup>1)</sup> Maximum allowed rated conditional short-circuit current (IEC 61800-5-1) of the electrical power network					

ACS880-01-...	Frame	ABB miniature circuit breaker		ABB moulded case circuit breaker (Tmax)	
		Type	kA <sup>1)</sup>	Type	kA <sup>1)</sup>
038A-3	R3	S 203 M/P-B/C 63	5	-	-
045A-3	R4	S 803 S-B/C 63	10	-	-
061A-3	R4	S 803 S-B/C 75	10	-	-
072A-3	R5	S 803 S-B/C 125	10	XT2 L 160 Ekip LS/I In=160 3p F F	65
087A-3	R5	S 803 S-B/C 125	10	XT2 L 160 Ekip LS/I In=160 3p F F	65
105A-3	R6	-	-	XT4 L 250 Ekip LS/I In=250 3p F F	65
145A-3	R6	-	-	XT4 L 250 Ekip LS/I In=250 3p F F	65
169A-3	R7	-	-	XT4 L 250 Ekip LS/I In=250 3p F F	65
206A-3	R7	-	-	T4 L 320 PR221DS-LS/I In=320 3p F F	65
246A-3	R8	-	-	T5 L 400 PR221DS-LS/I In=400 3p F F	65
293A-3	R8	-	-	T5 L 630 PR221DS-LS/I In=630 3p F F	65
363A-3	R9	-	-	T5 L 630 PR221DS-LS/I In=630 3p F F	65
430A-3	R9	-	-	T5 L 630 PR221DS-LS/I In=630 3p F F	65
<b>U<sub>n</sub> = 500 V</b>					
02A1-5	R1	S 803 S-B/C 6	10	-	-
03A0-5	R1	S 803 S-B/C 6	10	-	-
03A4-5	R1	S 803 S-B/C 6	10	-	-
04A8-5	R1	S 803 S-B/C 10	10	-	-
05A2-5	R1	S 803 S-B/C 13	10	-	-
07A6-5	R1	S 803 S-B/C 13	10	-	-
11A0-5	R1	S 803 S-B/C 20	10	-	-
014A-5	R2	S 803 S-B/C 25	10	-	-
021A-5	R2	S 803 S-B/C 32	10	-	-
027A-5	R3	S 803 S-B/C 50	10	-	-
034A-5	R3	S 803 S-B/C 63	10	-	-
040A-5	R4	S 803 S-B/C 63	10	-	-
052A-5	R4	S 803 S-B/C 75	10	-	-
065A-5	R5	S 803 S-B/C 125	10	XT2 L 160 Ekip LS/I In=160 3p F F	65
077A-5	R5	S 803 S-B/C 125	10	XT2 L 160 Ekip LS/I In=160 3p F F	65
096A-5	R6	-	-	XT4 L 250 Ekip LS/I In=250 3p F F	65
124A-5	R6	-	-	XT4 L 250 Ekip LS/I In=250 3p F F	65
156A-5	R7	-	-	XT4 L 250 Ekip LS/I In=250 3p F F	65
180A-5	R7	-	-	T4 L 320 PR221DS-LS/I In=320 3p F F	65
240A-5	R8	-	-	T5 L 630 PR221DS-LS/I In=630 3p F F	65
260A-5	R8	-	-	T5 L 630 PR221DS-LS/I In=630 3p F F	65
302A-5	R9	-	-	T5 L 630 PR221DS-LS/I In=630 3p F F	65

<sup>1)</sup> Maximum allowed rated conditional short-circuit current (IEC 61800-5-1) of the electrical power network

ACS880-01-...	Frame	ABB miniature circuit breaker		ABB moulded case circuit breaker (Tmax)	
		Type	kA 1)	Type	kA 1)
361A-5	R9	-	-	T5 L 630 PR221DS-LS/I In=630 3p F F	65
414A-5	R9	-	-	T5 L 630 PR221DS-LS/I In=630 3p F F	65
$U_n = 690 \text{ V}$					
07A4-7	R3	S 803 S-B/C 13	10	XT2 L 160 Ekip LS/I In=160 3p F F	25
09A9-7	R3	S 803 S-B/C 20	10	XT2 L 160 Ekip LS/I In=160 3p F F	25
14A3-7	R3	S 803 S-B/C 25	10	XT2 L 160 Ekip LS/I In=160 3p F F	25
019A-7	R3	S 803 S-B/C 32	10	XT2 L 160 Ekip LS/I In=63 3p F F	18
023A-7	R3	S 803 S-B/C 50	10	XT2 L 160 Ekip LS/I In=63 3p F F	18
027A-7	R3	S 803 S-B/C 63	10	XT2 L 160 Ekip LS/I In=63 3p F F	18
035A-7	R5	S 803 S-B/C 63	10	XT2 L 160 Ekip LS/I In=63 3p F F	18
042A-7	R5	S 803 S-B/C 80	10	XT2 L 160 Ekip LS/I In=100 3p F F	18
049A-7	R5	S 803 S-B/C 80	10	XT2 L 160 Ekip LS/I In=100 3p F F	18
061A-7	R6	S 803 S-B/C 125	10	XT2 L 160 Ekip LS/I In=160 3p F F	20
084A-7	R6	S 803 S-B/C 125	10	XT2 L 160 Ekip LS/I In=160 3p F F	20
098A-7	R7	-	-	XT4 L 250 Ekip LS/I In=250 3p F F	20
119A-7	R7	-	-	XT4 L 250 Ekip LS/I In=250 3p F F	20
142A-7	R8	-	-	XT4 L 250 Ekip LS/I In=250 3p F F	20
174A-7	R8	-	-	T4 L 320 PR221DS-LS/I In=320 3p F F	35
210A-7	R9	-	-	T5 L 400 PR221DS-LS/I In=400 3p F F	35
271A-7	R9	-	-	T5 L 630 PR221DS-LS/I In=630 3p F F	35
3AXD00000588487, 3AXD10000114581					
†) Maximum allowed rated conditional short-circuit current (IEC 61800-5-1) of the electrical power network					

**Note:** Other circuit breakers can be used with drive if they provide the same electrical characteristics. ABB does not assume any liability whatsoever for the correct function and protection with circuit breakers not listed. Furthermore, if the recommendations given by ABB are not obeyed, the drive can experience problems that warranty does not cover.

## Circuit breakers (UL)

### ■ ABB inverse time circuit breakers

The drives are suitable for use on a circuit capable of delivering not more than 65 kA symmetrical amperes (RMS) at 240 V, 480 V, and 600 V maximum when protected by circuit breakers in the tables below.

Additional fuse protection is not required when using the circuit breakers herein. Circuit breakers are not required to be in the same enclosure as the drive.



Rules below must be followed when using these breakers. Follow rules 1...9 for all drives when implementing circuit breakers. Then follow rules 10...18 depending upon the drive voltage rating.

For more information see the manual supplement ([3AXD50000645015 \[English\]](#)).

**230 V circuit breakers**

ACS880-01-...	Frame	Input current	Circuit breaker maximum current	Circuit breaker voltage	Enclosure minimum volume	Drive volume	Circuit breaker (ABB)
		A	A	V	in <sup>3</sup>	in <sup>3</sup>	
$U_N = 230\text{ V}$							
04A6-2	R1	4.4	15	240	‡	681	XT2Nαβ015#*****
06A6-2	R1	6.3	15	240	‡	681	XT2Nαβ015#*****
07A5-2	R1	7.1	15	240	‡	681	XT2Nαβ015#*****
10A6-2	R1	10.1	15	240	‡	681	XT2Nαβ015#*****
16A8-2	R2	16.0	40	240	‡	750	XT2Nαβ040#*****
24A3-2	R2	23.1	40	240	‡	750	XT2Nαβ040#*****
031A-2	R3	29.3	50	240	‡	1011	XT2Nαβ050#*****
046A-2	R4	44	100	240	‡	1669	XT2Nαβ100#*****
061A-2	R4	58	100	240	‡	1669	XT2Nαβ100#*****
075A-2	R5	72	150	240	‡	2030	XT4Nαβ150#*****
087A-2	R5	83	150	240	‡	2030	XT4Nαβ150#*****
115A-2	R6	109	200	240	‡	2880	XT4Nαβ200#*****
145A-2	R6	138	200	240	‡	2880	XT4Nαβ200#*****
170A-2	R7	162	300	240	‡	3369	XT5Nαβ30A#*****
206A-2	R7	196	300	240	‡	3369	XT5Nαβ30A#*****
274A-2	R8	260	400	240	‡	3858	XT5Nαβ40A#*****

‡ Enclosure minimum volume is not applicable

Follow rules 1...11 below.

**480 V circuit breakers**

ACS880-01-...	Frame	Input current	Circuit breaker maximum current	Circuit breaker voltage	Enclosure minimum volume	Drive volume	Circuit breaker (ABB)	Maximum $I^2t$	Maximum / peak
		A	A	V	in <sup>3</sup>	in <sup>3</sup>			
$U_N = 480\text{ V}$								A <sup>2</sup> s	kA

## 230 Technical data

ACS880-01-...	Frame	Input current	Circuit breaker maximum current	Circuit breaker voltage	Enclosure minimum volume	Drive volume	Circuit breaker (ABB)	Maximum $I^2t$	Maximum / peak
		A	A	V	in <sup>3</sup>	in <sup>3</sup>		65 kA @ 480 V	
02A1-5	R1	2.1	15	480	8100	681	XT2Hαβ015#*****	0.51x10 <sup>6</sup>	23.2
03A0-5	R1	3.0	15	480	8100	681	XT2Hαβ015#*****	0.51x10 <sup>6</sup>	23.2
03A4-5	R1	3.4	15	480	8100	681	XT2Hαβ015#*****	0.51x10 <sup>6</sup>	23.2
04A8-5	R1	4.8	15	480	8100	681	XT2Hαβ015#*****	0.51x10 <sup>6</sup>	23.2
05A2-5	R1	5.2	15	480	8100	681	XT2Hαβ015#*****	0.51x10 <sup>6</sup>	23.2
07A6-5	R1	7.6	15	480	8100	681	XT2Hαβ015#*****	0.51x10 <sup>6</sup>	23.2
11A0-5	R1	11	15	480	8100	681	XT2Hαβ015#*****	0.51x10 <sup>6</sup>	23.2
014A-5	R2	14	30	480	27720	750	XT2Hαβ030#*****	0.51x10 <sup>6</sup>	23.2
021A-5	R2	21	30	480	27720	750	XT2Hαβ030#*****	0.51x10 <sup>6</sup>	23.2
027A-5	R3	27	50	480	27720	1011	XT2Hαβ050#*****	0.51x10 <sup>6</sup>	23.2
034A-5	R3	34	50	480	27720	1011	XT2Hαβ050#*****	0.51x10 <sup>6</sup>	23.2
040A-5	R4	40	70	480	30240	1669	XT2Hαβ070#*****	0.51x10 <sup>6</sup>	23.2
052A-5	R4	52	70	480	30240	1669	XT2Hαβ070#*****	0.51x10 <sup>6</sup>	23.2
065A-5	R5	65	125	480	30240	2030	XT2Hαβ125#*****	0.51x10 <sup>6</sup>	23.2
077A-5	R5	77	125	480	30240	2030	XT2Hαβ125#*****	0.51x10 <sup>6</sup>	23.2
096A-5	R6	96	225	480	16200	2880	XT4Hαβ225#*****	0.98x10 <sup>6</sup>	30
124A-5	R6	124	225	480	16200	2880	XT4Hαβ225#*****	0.98x10 <sup>6</sup>	30
156A-5	R7	156	250	480	18900	3369	XT4Hαβ250#*****	0.98x10 <sup>6</sup>	30
180A-5	R7	180	250	480	18900	3369	XT4Hαβ250#*****	0.98x10 <sup>6</sup>	30
240A-5	R8	240	400	480	32400	3858	XT5Hαβ40A#*****	4.2x10 <sup>6</sup>	47.9
260A-5	R8	260	400	480	32400	3858	XT5Hαβ40A#*****	4.2x10 <sup>6</sup>	47.9
302A-5	R9	302	600	480	32400	5226	XT5Hαβ60B#*****	4.2x10 <sup>6</sup>	47.9
361A-5	R9	361	600	480	32400	5226	XT5Hαβ60B#*****	4.2x10 <sup>6</sup>	47.9
414A-5	R9	414	600	480	32400	5226	XT5Hαβ60B#*****	4.2x10 <sup>6</sup>	47.9

Follow rules 1...9 and 12...17 below.

### 600 V circuit breakers

ACS880-01-...	Frame	Input current	Circuit breaker maximum current	Circuit breaker voltage	Enclosure minimum volume	Drive volume	Circuit breaker (ABB)	Maximum $I^2t$	Maximum / peak
		A	A	V	in <sup>3</sup>	in <sup>3</sup>		65 kA @ 600 V	
$U_N = 575 V$									

ACS880-01-...	Frame	Input current	Circuit breaker maximum current	Circuit breaker voltage	Enclosure minimum volume	Drive volume	Circuit breaker (ABB)	Maximum $I^2t$	Maximum I peak
		A	A	V	in <sup>3</sup>	in <sup>3</sup>	65 kA @ 600 V	A <sup>2</sup> s	kA
07A4-7	R3	7	35	600	28980	1011	XT4Vαβ035#*****	1.2x10 <sup>6</sup>	31.5
09A9-7	R3	9.4	35	600	28980	1011	XT4Vαβ035#*****	1.2x10 <sup>6</sup>	31.5
14A3-7	R3	13.6	35	600	28980	1011	XT4Vαβ035#*****	1.2x10 <sup>6</sup>	31.5
019A-7	R3	18	35	600	28980	1011	XT4Vαβ035#*****	1.2x10 <sup>6</sup>	31.5
023A-7	R3	22	35	600	28980	1011	XT4Vαβ035#*****	1.2x10 <sup>6</sup>	31.5
027A-7	R3	27	35	600	28980	1011	XT4Vαβ035#*****	1.2x10 <sup>6</sup>	31.5
035A-7	R5	41	70	600	28980	2030	XT4Vαβ070#*****	1.2x10 <sup>6</sup>	31.5
042A-7	R5	52	70	600	28980	2030	XT4Vαβ070#*****	1.2x10 <sup>6</sup>	31.5
049A-7	R5	52	70	600	28980	2030	XT4Vαβ070#*****	1.2x10 <sup>6</sup>	31.5
061A-7	R6	62	125	600	24840	2880	XT4Vαβ125#*****	1.2x10 <sup>6</sup>	31.5
084A-7	R6	77	125	600	24840	2880	XT4Vαβ125#*****	1.2x10 <sup>6</sup>	31.5
098A-7	R7	99	200	600	18900	3369	XT4Vαβ200#*****	1.2x10 <sup>6</sup>	31.5
119A-7	R7	125	200	600	18900	3369	XT4Vαβ200#*****	1.2x10 <sup>6</sup>	31.5
142A-7	R8	144	250	600	32400	3858	XT4Vαβ250#*****	1.2x10 <sup>6</sup>	31.5
174A-7	R8	180	250	600	32400	3858	XT4Vαβ250#*****	1.2x10 <sup>6</sup>	31.5
210A-7	R9	242	400	600	32400	5226	XT5Lαβ40A#*****	4.2x10 <sup>6</sup>	51.4
271A-7	R9	271	400	600	32400	5226	XT5Lαβ40A#*****	4.2x10 <sup>6</sup>	51.4

Follow rules 1...9, 12...13 and 18 below.

#### Notes:

1. Drives that have an enclosure minimum volume listed must be mounted in an enclosure  $\geq$  enclosure minimum volume specified in the tables above.
2. When multiple drives that have an enclosure minimum volume specified are installed in the same enclosure, minimum volume of the enclosure is determined by largest enclosure minimum volume of the drives to be placed in the enclosure, plus the volume(s) of each additional drive. i.e. for the 480V R6 and R3 drive select enclosure with the volume  $\geq 16200+1011 = 17211$  in<sup>3</sup>.
3. For UL Open Type, UL Type 1 or UL Type 12 drives that have a minimum enclosure volume indicated with  $\alpha$ , no minimum enclosure volume is required but the drive must be mounted inside an enclosure.
4. If combining a drive with an enclosure minimum volume specified and others with an enclosure minimum volume indicated with  $\alpha$ , start with the largest specified enclosure minimum volume listed and add the drive volumes for the other drives.

5. If you are only mounting drives with no enclosure minimum volume specified, you have no restrictions on the enclosure size, but follow air clearances specified in the drive HW manuals for sufficient ventilation around each drive.
  6. UL Open Type, UL Type 1 and UL Type 12 drives can be used inside of the enclosure. Use drive volume for all three types listed in the table when installing multiple drives in the enclosure.
  7. The ABB circuit breaker part number listed in the table is a base part number.
    - Symbol  $\alpha$  represents 80% or 100% allowable continuous current. Options allowed are U, Q, C and D.
    - Symbol  $\beta$  represents the number of poles for the breaker. Options allowed are 3 and 4.
    - Symbol # represents trip units. Trip units allowed include A thru C, E thru L, P thru Z. If using Ekip breakers, set the overload current of the circuit breaker equal to or less than the value shown in the “CB Maximum Current” column in the tables above.
    - The digits indicated with an “\*” represent accessories for the breakers and have no impact on the drive UL listing or performance or rating of the breaker.
    - For the ABB circuit breaker configurator refer to:  
[https://lowvoltage-configurator.tnb.com/configurator/#/config/tmax\\_xt](https://lowvoltage-configurator.tnb.com/configurator/#/config/tmax_xt).
  8. Ratings in the tables are maximum for the given circuit breaker frame size. Breakers of the same frame size and interrupting rating with lower current ratings are also allowed.
  9. Using a circuit breaker with a lower KAIC rating is not allowed even if the available SC current is less than 65 kA.
  10. **For 230 V drives:** 230 V drives were tested with ABB inverse time circuit breakers rated at 65 kA and 240 V. Other manufacturers' inverse time circuit breakers can be used if they are UL 489 listed, they are 240 V or higher, they have a 65 kA or higher interrupting rating and they have the same or lower nominal current rating than the ABB specified circuit breaker.
  11. **For 230 V drives:** Current limiting inverse time circuit breakers must not be used.
  12. **For 480 V and 600 V drives:** When designing UL508A panels, Article SB 4.2.3 Exception No. 3 allows the use of other manufacturers' current limiting inverse time circuit breakers which have same voltage, current and interrupting rating, if  $I_{peak}$  and  $I^2t$  are the same or less than the ABB specified circuit breaker.
  13. **For 480 V and 600 V drives:** Non-current limiting inverse time circuit breakers must not be used.
  14. **For 480 V drives:** Enclosures for frames R1 and R9 must have a solid bottom directly below the drive. i.e. fans, filters or louvers cannot be mounted directly
-

below the drive but can be mounted in adjacent areas on the bottom of the enclosure.

15. **For 480 V drives:** Enclosures for frame R6 must have a solid top directly above the drive. Fans, filters our louvers cannot be mounted directly above the drive.
16. **For 480 V drives:** Only R8 frame drives with serial numbers beginning 1204107353 when built in Finland and 2205002140 when built in the U.S. may be protected with circuit breakers listed in the tables above.
17. **For 480 V drives:** Only R9 frame drives with serial numbers beginning 1204205581 when built in Finland and beginning 22106xxxxx when built in the U.S. may be protected with circuit breakers listed in the tables above.
18. **For 600 V drives:** Enclosures for frames R3, R5 and R9 must have a solid bottom directly below the drive. i.e. fans, filters or louvers cannot be mounted directly below the drive but can be mounted in adjacent areas on the bottom of the enclosure.
19. Alternative circuit breakers can be used if they meet certain characteristics. For acceptable breakers see [Alternate Fuses, MMPs and Circuit Breakers for ABB Drives \(3AXD50000645015 \[English\]\)](#).

## Dimensions, weights and free space requirements

Frame	IP21				
	H1	H2	W	D	Weight
	mm	mm	mm	mm	kg
R1	409	370	155	226	7.0
R2	409	370	155	249	8.4
R3	475	420	172	261	10.8
R4	580	490	203	274	18.6
R5	732	596	203	274	22.8
R6	727	569	252	357	42.2
R7	880	621	284	365	53.0
R8	965	700	300	386	68.0
R9	955	700	380	413	95.0

Frame	UL type 1				
	H1	H2	W	D	Weight
	in	in	in	in	lb
R1	16.11	14.57	6.10	8.89	15
R2	16.11	14.57	6.10	9.80	19
R3	18.71	16.54	6.77	10.28	24
R4	22.85	19.29	7.99	10.79	41

Frame	UL type 1				
	H1	H2	W	D	Weight
	in	in	in	in	lb
R5	28.80	23.46	7.99	10.77	50
R6	28.60	22.40	9.92	14.10	93
R7	34.66	24.45	11.18	14.35	117
R8	38.01	27.56	11.81	15.21	150
R9	37.59	27.56	14.96	16.27	209

Frame	IP55				
	H1	H2	W	D	Weight
	mm	mm	mm	mm	kg
R1	450	-	162	292	8.1
R2	450	-	162	315	9.5
R3	525	-	180	327	12.0
R4	580	-	203	344	19.1
R5	732	-	203	344	23.4
R6	727	-	252	421	42.9
R7	880	-	284	423	54.0
R8	966	-	300	452	74.0
R9	955	-	380	477	102.0

- H1 Height with cable entry box
- H2 Height without cable entry box (option +P940)
- W Width with cable entry box
- D Depth with cable entry box

Hood increases height with 155 mm (6.10 in) in frames R4 to R8 and with 230 mm (9.06 in) in frame R9.

Hood increases width with 23 mm (0.91 in) in frames R4 and R5, 40 mm (1.57 in) in frames R6 and R7 and 50 mm (1.97 in) in frames R8 and R9.

For more information on dimensions, see chapter Dimension drawings.  
 For dimensions and weights of option +P940 and +P944, see [ACS880...+P940 and +P944 drive modules supplement \(3AUA0000145446 \[English\]\)](#).  
 For dimensions of option +C135, see [ACS880-01...+C135 drives with flange mounting kit supplement \(3AXD50000349814 \[English\]\)](#). For the additional weight of the flange mounting kit, see the table below.

Frame	Weight of flange mounting kit (option +C135)	
	kg	lb
R1	2.9	6

Frame	Weight of flange mounting kit (option +C135)	
	kg	lb
R2	3.1	7
R3	4.5	10
R4	4.7	10
R5	4.7	10
R6	4.5	10
R7	5	11
R8	6	13
R9	7	15

### ■ Package dimensions

Frame	Package		
	Length	Width	Height
	mm	mm	mm
R1 (IP21)	574	256	281
R1 (IP55)	574	256	364
R2 (IP21)	574	256	304
R2 (IP55)	574	256	386
R3 (IP21)	624	256	316
R3 (IP55)	624	256	399
R4 (IP21)	691	290	329
R4 (IP55)	691	290	415
R5 (IP21)	896	293	329
R5 (IP55)	896	293	415
R6	870	325	580
R7	992	400	568
R8	1145	485	655
R9	1145	485	655

### Free space requirements

200 mm (7.87 in) free space is required at top of the drive.

300 mm (11.81 in) free space (when measured from the drive base without the cable entry box) is required at bottom of the drive.

## Losses, cooling data and noise

ACS880-01-...	Frame	Air flow		Typical power loss <sup>1)</sup>	Noise
		m <sup>3</sup> /h	ft <sup>3</sup> /min	W	dB(A)
<b>U<sub>n</sub> = 230 V</b>					
04A6-2	R1	44	26	61	50
06A6-2	R1	44	26	85	50
07A5-2	R1	44	26	96	50
10A6-2	R1	44	26	149	50
16A8-2	R2	88	52	210	59
24A3-2	R2	88	52	368	59
031A-2	R3	134	79	354	60
046A-2	R4	134	79	541	64
061A-2	R4	280	165	804	64
075A-2	R5	280	165	925	64
087A-2	R5	280	165	1142	64
115A-2	R6	435	256	1362	68
145A-2	R6	435	256	1935	68
170A-2	R7	450	265	1968	67
206A-2	R7	450	265	2651	67
274A-2	R8	550	324	3448	68
<b>U<sub>n</sub> = 400 V</b>					
02A4-3	R1	44	26	43	50
03A3-3	R1	44	26	52	50
04A0-3	R1	44	26	59	50
05A6-3	R1	44	26	78	50
07A2-3	R1	44	26	112	50
09A4-3	R1	44	26	146	50
12A6-3	R1	44	26	217	50
017A-3	R2	88	52	235	59
025A-3	R2	88	52	412	59
032A-3	R3	134	79	400	60
038A-3	R3	134	79	515	60
045A-3	R4	134	79	526	64
061A-3	R4	280	165	818	64
072A-3	R5	280	165	841	64
087A-3	R5	280	165	1129	64
105A-3	R6	435	256	1215	68
145A-3	R6	435	256	1962	68
169A-3	R7	450	265	2042	67



ACS880-01-...	Frame	Air flow		Typical power loss <sup>1)</sup> W	Noise dB(A)
		m <sup>3</sup> /h	ft <sup>3</sup> /min		
206A-3	R7	450	265	2816	67
246A-3	R8	550	324	3026	68
293A-3	R8	550	324	3630	68
363A-3	R9	1150	677	4688	70
430A-3	R9	1150	677	5797	70
<b>U<sub>n</sub> = 500 V</b>					
02A1-5	R1	44	26	42	50
03A0-5	R1	44	26	50	50
03A4-5	R1	44	26	55	50
04A8-5	R1	44	26	71	50
05A2-5	R1	44	26	76	50
07A6-5	R1	44	26	110	50
11A0-5	R1	44	26	180	50
014A-5	R2	88	52	191	59
021A-5	R2	88	52	330	59
027A-5	R3	134	79	326	60
034A-5	R3	134	79	454	60
040A-5	R4	134	79	424	64
052A-5	R4	280	165	600	64
065A-5	R5	280	165	715	64
077A-5	R5	280	165	916	64
096A-5	R6	435	256	1157	68
124A-5	R6	435	256	1673	68
156A-5	R7	450	265	1840	67
180A-5	R7	450	265	2281	67
240A-5	R8	550	324	2912	68
260A-5	R8	550	324	3325	68
302A-5	R9	1150	677	3663	70
361A-5	R9	1150	677	4781	70
414A-5	R9	1150	677	5672	70
<b>U<sub>n</sub> = 690 V</b>					
07A4-7	R3	134	79	101	60
09A9-7	R3	134	79	128	60
14A3-7	R3	134	79	189	60
019A-7	R3	134	79	271	60
023A-7	R3	134	79	338	60
027A-7	R3	134	79	426	60
035A-7	R5	280	165	416	64

ACS880-01-...	Frame	Air flow		Typical power loss <sup>1)</sup>	Noise
		m <sup>3</sup> /h	ft <sup>3</sup> /min	W	dB(A)
042A-7	R5	280	165	524	64
049A-7	R5	280	165	650	64
061A-7	R6	435	256	852	68
084A-7	R6	435	256	1303	68
098A-7	R7	450	265	1416	67
119A-7	R7	450	265	1881	67
142A-7	R8	550	324	1970	68
174A-7	R8	550	324	2670	68
210A-7	R9	1150	677	2903	70
271A-7	R9	1150	677	4182	70

<sup>1)</sup> Typical drive losses when it operates at 90% of the motor nominal frequency and 100% of the motor nominal current.

### Cooling air flow and heat dissipation for flange mounting (option +C135)

ACS880-01-...	Frame	Air flow (option +C135)		Heat dissipation (option +C135)	
		Heatsink	Front	Heatsink	Front
		m <sup>3</sup> /h	m <sup>3</sup> /h	W	W
<b>U<sub>n</sub> = 230 V</b>					
04A6-2	R1	44	9	36	25
06A6-2	R1	44	9	59	26
07A5-2	R1	44	9	70	26
10A6-2	R1	44	9	123	27
16A8-2	R2	88	16	170	39
24A3-2	R2	88	16	324	44
031A-2	R3	134	22	298	56
046A-2	R4	134	32	449	93
061A-2	R4	280	32	690	114
075A-2	R5	280	42	804	121
087A-2	R5	280	42	1002	140
115A-2	R6	435	52	1214	147
145A-2	R6	435	52	1767	168
170A-2	R7	450	75	1790	179
206A-2	R7	450	75	2443	208
274A-2	R8	550	120	3173	274
<b>U<sub>n</sub> = 400 V</b>					

ACS880-01-...	Frame	Air flow (option +C135)		Heat dissipation (option +C135)	
		Heatsink	Front	Heatsink	Front
		m <sup>3</sup> /h	m <sup>3</sup> /h	W	W
02A4-3	R1	44	9	18	25
03A3-3	R1	44	9	27	25
04A0-3	R1	44	9	34	25
05A6-3	R1	44	9	52	26
07A2-3	R1	44	9	86	26
09A4-3	R1	44	9	120	27
12A6-3	R1	44	9	189	28
017A-3	R2	88	16	196	40
025A-3	R2	88	16	367	45
032A-3	R3	134	22	343	57
038A-3	R3	134	22	451	64
045A-3	R4	134	32	436	90
061A-3	R4	280	32	704	114
072A-3	R5	280	42	726	115
087A-3	R5	280	42	988	141
105A-3	R6	435	52	1075	140
145A-3	R6	435	52	1798	164
169A-3	R7	450	75	1853	189
206A-3	R7	450	75	2593	223
246A-3	R8	550	120	2766	261
293A-3	R8	550	120	3317	313
363A-3	R9	1150	170	4286	401
430A-3	R9	1150	170	5332	465
$U_n = 500\text{ V}$					
02A1-5	R1	44	9	17	25
03A0-5	R1	44	9	25	25
03A4-5	R1	44	9	29	25
04A8-5	R1	44	9	45	26
05A2-5	R1	44	9	51	26
07A6-5	R1	44	9	84	26
11A0-5	R1	44	9	153	27
014A-5	R2	88	16	152	38
021A-5	R2	88	16	288	42
027A-5	R3	134	22	273	53
034A-5	R3	134	22	394	60
040A-5	R4	134	32	340	84
052A-5	R4	280	32	501	99

ACS880-01-...	Frame	Air flow (option +C135)		Heat dissipation (option +C135)	
		Heatsink	Front	Heatsink	Front
		m <sup>3</sup> /h	m <sup>3</sup> /h	W	W
065A-5	R5	280	42	609	106
077A-5	R5	280	42	792	124
096A-5	R6	435	52	1019	137
124A-5	R6	435	52	1521	153
156A-5	R7	450	75	1662	178
180A-5	R7	450	75	2083	198
240A-5	R8	550	120	2659	253
260A-5	R8	550	120	3050	274
302A-5	R9	1150	170	3311	352
361A-5	R9	1150	170	4379	403
414A-5	R9	1150	170	5217	455
<i>U<sub>n</sub></i> = 690 V					
07A4-7	R3	134	22	60	41
09A9-7	R3	134	22	87	42
14A3-7	R3	134	22	146	43
019A-7	R3	134	22	226	45
023A-7	R3	134	22	290	47
027A-7	R3	134	22	376	50
035A-7	R5	280	42	337	78
042A-7	R5	280	42	440	84
049A-7	R5	280	42	560	90
061A-7	R6	435	52	729	122
084A-7	R6	435	52	1173	130
098A-7	R7	450	75	1276	140
119A-7	R7	450	75	1730	151
142A-7	R8	550	120	1797	173
174A-7	R8	550	120	2476	194
210A-7	R9	1150	170	2612	291
271A-7	R9	1150	170	3853	329

## Connector and entry data for the power cables

### ■ IEC

Input, motor, resistor and DC cable terminal screw sizes, accepted wire sizes (per phase) and tightening torques (*T*) are given below. *l* denotes stripping length inside the connector.

Frame	Cable entries		L1, L2, L3, T1/U, T2/V, T3/W				Grounding terminals	
	pcs	∅ *	Wire size	T (wire screw)		l	Max. wire size	T
		mm	mm <sup>2</sup>	M...	N-m	mm	mm <sup>2</sup>	N-m
R1	2	17	0.75...6	-	0.6	8	25	1.8
R2	2	17	0.75...6	-	0.6	8	25	1.8
R3	2	21	0.5...16	-	1.7	10	25	1.8
R4	2	24	0.5...35	-	3.3	18	25	2.9
R5	2	32	6...70	M8	15	18	35	2.9
R6	2	45	25...150	M10	30	30	185	9.8
R7	2	54	95...240 (25...150**)	M10	40	30	185	9.8
R8	4	45	2 × (50...150)	M10	40	30	2×185	9.8
R9	4	54	2 × (95...240)	M12	70	30	2×185	9.8

Frame	Cable entries		R-, R+/UDC+ and UDC- terminals				
	pcs	∅ *	Wire size	T (wire screw)		l	
		mm	mm <sup>2</sup>	M...	N-m	mm	
R1	1	17	0.75...6	-	0.6	8	
R2	1	17	0.75...6	-	0.6	8	
R3	1	21	0.5...16	-	1.7	10	
R4	1	24	0.5...35	-	3.3	18	
R5	1	32	6...70	M8	15	18	
R6	1	35	25...95	M8	20	30	
R7	1	43	25...150	M10	30	30	
R8	2	45	2 × (50...150)	M10	40	30	
R9	2	54	2 × (95...240)	M12	70	30	

\* maximum cable diameter accepted. For the entry plate hole diameters, see chapter *Dimension drawings*.

\*\* 525...690 V drives

**Note:**

- The minimum specified wire size does not necessarily have sufficient current carrying capacity at maximum load.
- The terminals do not accept a conductor that is one size larger than the maximum specified wire size.
- For frames R1...R7: The maximum number of conductors per terminal is 1. For frames R8 and R9: The maximum number of conductors per terminal is 2.
- When you use a cable size smaller than what is accepted by the terminal, remove the terminal and use suitable cable lugs for connecting the cable directly under the head of the bolt.

■ **UL**

Input, motor, resistor and DC cable terminal screw sizes, accepted wire sizes (per phase) and tightening torques (T) in US units are given below. *l* denotes stripping length inside the connector

Frame	Cable entries		L1, L2, L3, T1/U, T2/V, T3/W				Grounding terminals	
	pcs	∅ *	Wire size	T (Wire screw)		<i>l</i>	Max. wire size	T
		in	kcmil/AWG	M...	lbf-ft	in	AWG	lbf-ft
R1	2	0.67	18...10	-	0.44	0.31	4	1.3
R2	2	0.67	18...10	-	0.44	0.31	4	1.3
R3	2	0.83	20...6	-	1.25	0.39	4	1.3
R4	2	0.94	20...2	-	2.4	0.70	4	2.1
R5	2	1.26	6...1/0	M8	11.0	0.70	2	2.1
R6	2	1.77	4...300 MCM	M10	22.1	1.18	350 MCM	7.2
R7	2	2.13	3/0...400 MCM (4...300 MCM**)	M10	29.5	1.18	350 MCM	7.2
R8	4	1.77	2 × (1/0...300 MCM)	M10	29.5	1.18	2 × 350 MCM	7.2
R9	4	2.13	2 × (3/0...500 MCM)	M12	51.6	1.18	2 × 350 MCM	7.2

Frame	Cable entries		R-, R+/UDC+ and UDC- terminals			
	pcs	∅ *	Wire size	T (wire screw)		<i>l</i>
		in	kcmil/AWG	M...	lbf-ft	mm
R1	1	0.67	18...10	-	0.44	0.31
R2	1	0.67	18...10	-	0.44	0.31
R3	1	0.83	20...6	-	1.25	0.39
R4	1	0.94	20...2	-	2.4	0.70
R5	1	1.26	6...1/0	M8	11.0	1.18
R6	1	1.38	4...3/0	M8	14.8	1.18
R7	1	1.69	4...300 MCM	M10	22,1	1.18
R8	2	1.77	2 × (1/0...300 MCM)	M10	29.5	1.18
R9	2	2.13	2 × (3/0...500 MCM)	M12	51.6	1.18

\* maximum cable diameter accepted. Cable connector inside diameter: 3/4" (frames R1 and R2), 1" (R3). For the entry plate hole diameters, see chapter Dimension drawings.

\*\* 525...690 V drives

**Note:**

- The minimum specified wire size does not necessarily have sufficient current carrying capacity at maximum load.
- For IEC installations using mm<sup>2</sup> cable, the terminals do not accept a conductor that is one size larger than the recommended wire size. For NEC installations using AWG cable, this applies only to the R2 frame drive.
- For frames R1...R7: The maximum number of conductors per terminal is 1. For frames R8 and R9: The maximum number of conductors per terminal is 2.

## Connector data for the control cables

See chapter Control unit.

## Power cables

The table below gives typical copper and aluminum cable types with concentric copper shield for the drives with nominal current. For terminal and entry data for power cables, see [Connector and entry data for the power cables](#) (page 240).

**Note:** Aluminum cables are not allowed in UL (NEC) installations.

Drive type ACS880- 01-...	Frame size	IEC <sup>1)</sup>		UL (NEC) <sup>2)</sup>
		Cu cable type	Al cable type	Cu cable type
		mm <sup>2</sup>	mm <sup>2</sup>	AWG/kcmil
$U_n = 230 \text{ V}$				
04A6-2	R1	3×1.5	-	14
06A6-2	R1	3×1.5	-	14
07A5-2	R1	3×1.5	-	14
10A6-2	R1	3×1.5	-	14
16A8-2	R2	3×6	-	10
24A3-2	R2	3×6	-	8
031A-2	R3	3×10	-	8
046A-2	R4	3×16	-	6
061A-2	R4	3×25	-	4
075A-2	R5	3×35	3×50	3
087A-2	R5	3×35	3×70	2
115A-2	R6	3×50	3×70	1/0
145A-2	R6	3×95	3×120	3/0
170A-2	R7	3×120	3×150	4/0
206A-2	R7	3×150	3×240	300 MCM
274A-2	R8	2 × (3×95) <sup>3)</sup>	2 × (3×120)	2 × 2/0
$U_n = 400 \text{ V}$				

## 244 Technical data

Drive type ACS880- 01-...	Frame size	IEC <sup>1)</sup>		UL (NEC) <sup>2)</sup>
		Cu cable type	Al cable type	Cu cable type
		mm <sup>2</sup>	mm <sup>2</sup>	AWG/kcmil
02A4-3	R1	3x1.5	-	-
03A3-3	R1	3x1.5	-	-
04A0-3	R1	3x1.5	-	-
05A6-3	R1	3x1.5	-	-
07A2-3	R1	3x1.5	-	-
09A4-3	R1	3x1.5	-	-
12A6-3	R1	3x1.5	-	-
017A-3	R2	3x6	-	-
025A-3	R2	3x6	-	-
032A-3	R3	3x10	-	-
038A-3	R3	3x10	-	-
045A-3	R4	3x16	-	-
061A-3	R4	3x25	-	-
072A-3	R5	3x35	3x50	-
087A-3	R5	3x35	3x70	-
105A-3	R6	3x50	3x70	-
145A-3	R6	3x95	3x120	-
169A-3	R7	3x120	3x150	-
206A-3	R7	3x150	3x240	-
246A-3	R8	2 × (3x70) <sup>3)</sup>	2 × (3x95)	-
293A-3	R8	2 × (3x95) <sup>3)</sup>	2 × (3x120)	-
363A-3	R9	2 × (3x120)	2 × (3x185)	-
430A-3	R9	2 × (3x150)	2 × (3x240)	-
$U_n = 500 \text{ V}$				
02A1-5	R1	3x1.5	-	14
03A0-5	R1	3x1.5	-	14
03A4-5	R1	3x1.5	-	14
04A8-5	R1	3x1.5	-	14
05A2-5	R1	3x1.5	-	14
07A6-5	R1	3x1.5	-	14
11A0-5	R1	3x1.5	-	14
014A-5	R2	3x6	-	12
021A-5	R2	3x6	-	10
027A-5	R3	3x10	-	8
034A-5	R3	3x10	-	8
040A-5	R4	3x16	-	6
052A-5	R4	3x25	-	4



Drive type ACS880- 01-...	Frame size	IEC <sup>1)</sup>		UL (NEC) <sup>2)</sup>
		Cu cable type	Al cable type	Cu cable type
		mm <sup>2</sup>	mm <sup>2</sup>	AWG/kcmil
065A-5	R5	3x35	3x35	4
077A-5	R5	3x35	3x50	3
096A-5	R6	3x50	3x70	1
124A-5	R6	3x95	3x95	2/0
156A-5	R7	3x120	3x150	3/0
180A-5	R7	3x150	3x185	4/0
240A-5	R8	2 × (3x70) <sup>3)</sup>	2 × (3x95)	2 × 1/0 or 350 MCM
260A-5	R8	2 × (3x70) <sup>3)</sup>	2 × (3x95)	2 × 2/0
302A-5	R9	2 × (3x95)	2 × (3x120)	2 × 3/0
361A-5	R9	2 × (3x120)	2 × (3x185)	2 × 4/0
414A-5	R9	2 × (3x150)	2 × (3x240)	2 × 300 MCM
$U_n = 690 \text{ V}$				
07A4-7	R3	3x1.5	-	14
09A9-7	R3	3x1.5	-	14
14A3-7	R3	3x2.5	-	12
019A-7	R3	3x4	-	10
023A-7	R3	3x6	-	10
027A-7	R3	3x10	-	8
035A-7	R5	3x10	3x25	6
042A-7	R5	3x16	3x25	6
049A-7	R5	3x16	3x25	6
061A-7	R6	3x25	3x35	4
084A-7	R6	3x35	3x50	3
098A-7	R7	3x50	3x70	1
119A-7	R7	3x70	3x95	2/0
142A-7	R8	3x95 <sup>3)</sup>	3x120	3/0
174A-7	R8	3x120 <sup>3)</sup>	3x150	4/0
210A-7	R9	3x185	2 × (3x95)	350 MCM
271A-7	R9	3x240	2 × (3x120)	500 MCM

1) The cable sizing is based on max. 9 cables laid on a cable ladder side by side, three ladder type trays one on top of the other, ambient temperature 30 °C, PVC insulation, surface temperature 70 °C (EN 60204-1 and IEC 60364-5-52/2001). For other conditions, size the cables according to local safety regulations, appropriate input voltage and the load current of the drive. See also [Connector and entry data for the power cables \(page 240\)](#) for the accepted cable sizes of the drive.

2) The cable sizing is based on NEC Table 310-16 for copper wires, 75 °C (167 °F) wire insulation at 40 °C (104 °F) ambient temperature. Not more than three

current-carrying conductors in raceway or cable or earth (directly buried). For other conditions, size the cables according to local safety regulations, appropriate input voltage and the load current of the drive. See also UL (page 242) for the accepted cable sizes of the drive.

The biggest cable size accepted by the connection terminals of frame R8 is 2 × (3×150) or 2 × 4/0. In IEC installations, the biggest possible cable size is 3x240 or 400 MCM if the terminal type is changed and the cable entry box is not used.

**Temperature:** For IEC, select a cable rated for at least 70 °C maximum permissible temperature of conductor in continuous use. For North America, power cables must be rated for 75 °C (167 °F) or higher.

**Voltage:** 600 V AC cable is accepted for up to 500 V AC. 750 V AC cable is accepted for up to 600 V AC. 1000 V AC cable is accepted for up to 690 V AC.

### Electrical power network specification

Voltage ( $U_1$ )	ACS880-01-xxxx-2 drives: 208 ... 240 V AC 3-phase +10%...-15%. This is indicated in the type designation label as typical input voltage level 3~230 V AC. ACS880-01-xxxx-3 drives: 380 ... 415 V AC 3-phase +10%...-15%. This is indicated in the type designation label as typical input voltage level 3~400 V AC. ACS880-01-xxxx-5 drives: 380 ... 500 V AC 3-phase +10%...-15%. This is indicated in the type designation label as typical input voltage levels 3~400/480/500 V AC. ACS880-01-xxxx-7 drives: 525 ... 690 V AC 3-phase +10%...-15%. This is indicated in the type designation label as typical input voltage levels 3~525/600/690 V AC.
Network type	TN (grounded) and IT (ungrounded) systems. However, 690 V drives must not be installed on corner-grounded or midpoint-grounded delta systems.
Rated conditional short-circuit current $I_{cc}$ (IEC 61439-1)	65 kA when protected by fuses given in the fuse tables
Short-circuit current protection rating (UL 61800-5-1, CSA C22.2 No.274-17)	US and Canada: The drive is suitable for use on a circuit capable of delivering not more than 100 kA symmetrical amperes rms at 600 V maximum when protected by fuses given in the fuse table.
Frequency ( $f_1$ )	50/60 Hz, variation $\pm 5\%$ , maximum rate of change 17%/s
Imbalance	Max. $\pm 3\%$ of nominal phase to phase input voltage
Fundamental power factor ( $\cos \phi_{11}$ )	0.98 (at nominal load)

## Motor connection data

<b>Motor types</b>	Asynchronous AC induction motors, permanent magnet synchronous motors, AC induction servomotors and ABB synchronous reluctance motors (SynRM motors)
<b>Voltage (<math>U_2</math>)</b>	0 to $U_1$ , 3-phase symmetrical. This is indicated in the type designation label as typical output voltage level as 3 0... $U_1$ , $U_{max}$ at the field weakening point.
<b>Frequency (<math>f_2</math>)</b>	0...500 Hz <u>For drives with du/dt filter:</u> 0...120 Hz <u>For drives with sine filter:</u> 0...120 Hz
<b>Current</b>	See section <i>Ratings</i> .
<b>Maximum recommended motor cable length</b>	Frames R1...R3: 150 m (492 ft) Frames R4 to R9: 300 m (984 ft) With motor cables longer than 150 m (492 ft) or switching frequencies higher than default, the EMC Directive requirements may not be fulfilled. <b>Note:</b> Longer motor cables cause a motor voltage decrease which limits the available motor power. The decrease depends on the motor cable length and characteristics. A sine filter (optional) at the drive output also causes voltage decrease. Contact ABB for more information.

## Efficiency

Approximately 98% at nominal power level.

The efficiency is not calculated according to the ecodesign standard IEC 61800-9-2.

## Energy efficiency data (ecodesign)

Energy efficiency data according to IEC-61800-9-2 is available from the ecodesign tool (<https://ecodesign.drivesmotors.abb.com>).



## Protection classes

<b>Degree of protection (IEC/EN 60529)</b>	IP21, IP55. Option +P940 and +P944: IP20
<b>Enclosure type (UL 50/50E)</b>	UL Type 1, UL Type 12. Option +P940: UL Open Type. For indoor use only.
<b>Overvoltage category (IEC 60664-1)</b>	III
<b>Protective class (IEC/EN 61800-5-1)</b>	I

## Ambient conditions

Environmental limits for the drive are given below. The drive is to be used in a heated, indoor, controlled environment.

	<b>Operation</b> installed for station- ary use	<b>Storage</b> in the package	<b>Transportation</b> in the package
<b>Installation site altitude</b>	0 to 4000 m (13123 ft) above sea level <sup>1)</sup> <u>Above 1000 m (3281 ft)<sup>2)</sup></u> : see section Deratings (page 196).	-	-
<b>Air temperature</b>	-15 to +55 °C (5 to 131 °F). No frost allowed. See section Deratings (page 196).	-40 to +70 °C (-40 to +158 °F)	-40 to +70 °C (-40 to +158 °F)
<b>Relative humidity</b>	5 to 95%	Max. 95%	Max. 95%
	No condensation allowed. Maximum allowed relative humidity is 60% in the presence of corrosive gases.		
<b>Contamination (IEC 60721-3-3, IEC 60721-3-2, IEC 60721-3-1)</b>	IEC/EN 60721-3-3:2002	IEC 60721-3-1:1997	IEC 60721-3-2:1997
<b>Chemical gases</b>	Class 3C2.	Class 1C2	Class 2C2
<b>Solid particles</b>	Class 3S2. No conductive dust allowed.	Class 1S3	Class 2S2
<b>Pollution degree IEC/EN 60664-1</b>	2		
<b>Atmospheric pressure</b>	70 to 106 kPa 0.7 to 1.05 atmospheres	70 to 106 kPa 0.7 to 1.05 atmospheres	60 to 106 kPa 0.6 to 1.05 atmospheres

<b>Vibration</b> EN 60068-2-6:2008	Max. 1 mm (0.04 in) (5 to 13.2 Hz), max. 7 m/s <sup>2</sup> (23 ft/s <sup>2</sup> ) (13.2 to 100 Hz) sinusoidal	Max. 1 mm (0.04 in) (5 to 13.2 Hz), max. 7 m/s <sup>2</sup> (23 ft/s <sup>2</sup> ) (13.2 to 100 Hz) sinusoidal	Max. 3.5 mm (0.14 in) (2 to 9 Hz), max. 15 m/s <sup>2</sup> (49 ft/s <sup>2</sup> ) (9 to 200 Hz) sinusoidal															
<b>Vibration (ISTA)</b>	-	R1...R5 (ISTA 1A): Displacement, 25 mm peak to peak, 14200 vibratory impacts R6...R9 (ISTA 3E): Random, overall Grms level of 0.54																
<b>Shock/Drop (ISTA)</b>	Not allowed	R1...R5 (ISTA 1A): Drop, 6 faces, 3 edges and 1 corner <table border="1"> <thead> <tr> <th>Weight range</th> <th>mm</th> <th>in</th> </tr> </thead> <tbody> <tr> <td>0...10 kg (0...22 lb)</td> <td>760</td> <td>29.9</td> </tr> <tr> <td>10...19 kg (22...42 lb)</td> <td>610</td> <td>24.0</td> </tr> <tr> <td>19...28 kg (42...62 lb)</td> <td>460</td> <td>18.1</td> </tr> <tr> <td>28...41 kg (62...90 lb)</td> <td>340</td> <td>13.4</td> </tr> </tbody> </table> R6...R9 (ISTA 3E): Shock, incline impact: 1.2 m/s (3.94 ft/s) Shock, rotational edge drop: 230 mm (7.9 in)	Weight range	mm	in	0...10 kg (0...22 lb)	760	29.9	10...19 kg (22...42 lb)	610	24.0	19...28 kg (42...62 lb)	460	18.1	28...41 kg (62...90 lb)	340	13.4	With packing max. 100 m/s <sup>2</sup> (330 ft/s <sup>2</sup> ), 11 ms
Weight range	mm	in																
0...10 kg (0...22 lb)	760	29.9																
10...19 kg (22...42 lb)	610	24.0																
19...28 kg (42...62 lb)	460	18.1																
28...41 kg (62...90 lb)	340	13.4																

- 1) For neutral-grounded TN and TT systems and non-corner grounded IT systems.  
2) For corner-grounded TN, TT and IT systems.

## Colors

Drive enclosure: NCS 1502-Y (RAL 9002 / PMS 1C Cool Grey) and RAL 9017.

## Materials

### ■ Drive

Refer to [Recycling instructions and environmental information for ACS880-01 drives \(3AUA0000149383 \[English\]\)](#).

### ■ **Package materials for small wall-mounted drives and converter modules**

- Cardboard
- Molded pulp
- EPP (foam)
- PP (strapping)
- PE (plastic bag).

### ■ **Package materials for large wall-mounted drives and converter modules**

- Cardboard heavy duty quality with wet strength glue
- Plywood
- Wood
- PP (strapping)
- PE (VCI foil)
- Metal (fixing clamps, screws).

### ■ **Package materials for options, accessories and spare parts**

- Cardboard
- Kraft paper
- PP (straps)
- PE (foil, bubble wrap)
- Plywood, wood (only for heavy components).

Materials vary according to the item type, size and shape. Typical package consists of a cardboard box with paper filling or bubble wrap. ESD-safe packing materials are used for printed circuit boards and similar items.

### ■ **Materials of manuals**

Printed product manuals are recyclable paper. Product manuals are available on the Internet.

## **Disposal**

The main parts of the drive can be recycled to preserve natural resources and energy. Product parts and materials should be dismantled and separated.

Generally all metals, such as steel, aluminum, copper and its alloys, and precious metals can be recycled as material. Plastics, rubber, cardboard and other packaging material can be used in energy recovery. Printed circuit boards and large electrolytic

---

capacitors need selective treatment according to IEC 62635 guidelines. To aid recycling, plastic parts are marked with an appropriate identification code.

Contact your local ABB distributor for further information on environmental aspects and recycling instructions for professional recyclers. End of life treatment must follow international and local regulations.



## Applicable standards

The drive complies with the following standards. The compliance with the European Low Voltage Directive is verified according to standard EN 61800-5-1.	
IEC/EN 61800-3:2004 + A1:2012	Adjustable speed electrical power drive systems. Part 3: EMC requirements and specific test methods
IEC/EN 61800-5-1:2007	Adjustable speed electrical power drive systems. Part 5-1: Safety requirements – Electrical, thermal and energy
IEC 61800-5-2:2016 EN 61800-5-2:2007	Adjustable speed electrical power drive systems. Part 5-2: Safety requirements – Functional
IEC 61800-9-2: 2017	Adjustable speed electrical power drive systems – Part 9-2: Ecodesign for power drive systems, motor starters, power electronics and their driven applications – Energy efficiency indicators for power drive systems and motor starters
IEC 61508-1:2010	Functional safety of electrical/electronic/programmable electronic safety-related systems - Part 1: General requirements
IEC 61508-2:2010	Functional safety of electrical/electronic/programmable electronic safety-related systems - Part 2: Requirements for electrical/electronic/programmable electronic safety-related systems
EN 62061:2005 +AC:2010 +A1:2013 + A2:2015	Safety of machinery. Functional safety of safety-related electrical, electronic and programmable electronic control systems
EN/ISO 13849-1:2015	Safety of machinery — Safety-related parts of control systems — Part 1: General principles for design
EN/ISO 13849-2:2012	Safety of machinery — Safety-related parts of control systems — Part 2: Validation
IEC 60146-1-1:2009 EN 60146-1-1:2010	Semiconductor converters – General requirements and line commutated converters – Part 1-1: Specification of basic requirements
EN 60204-1:2006 + A1 2009 + AC:2010	Safety of machinery. Electrical equipment of machines. Part 1: General requirements. Provisions for compliance: The final assembler of the machine is responsible for installing: <ul style="list-style-type: none"> <li>• emergency-stop device</li> <li>• supply disconnecting device</li> </ul>
EN 60529:1991 + A2:2013	Degrees of protection provided by enclosures (IP code)
IEC 60664-1:2007	Insulation coordination for equipment within low-voltage systems. Part 1: Principles, requirements and tests



EN 50581:2012	Technical documentation for the assessment of electrical and electronic products with respect to the restriction of hazardous substances
IEC/EN 63000:2018	Technical documentation for the assessment of electrical and electronic products with respect to the restriction of hazardous substances
UL 61800-5-1: First Edition	Standard for Safety, Adjustable Speed Electrical Power Drive Systems – Part 5-1: Safety Requirements – Electrical, Thermal and Energy
CSA C22.2 No. 274-17	Adjustable speed drives
CSA C22.2 No. 22-10	General Requirements - Canadian Electrical Code, Part II

## Markings

These markings are attached to the drive:

	<p>CE mark</p> <p>Product complies with the applicable European Union legislation. For fulfilling the EMC requirements, see the additional information concerning the drive EMC compliance (IEC/EN 61800-3).</p>
	<p>TÜV Safety Approved mark (functional safety)</p> <p>Product contains Safe torque off and possibly other (optional) safety functions which are certified by TÜV according to the relevant functional safety standards. Applicable to drives and inverters; not applicable to supply, brake or DC/DC converter units or modules.</p>
	<p>UKCA (UK Conformity Assessed) mark</p> <p>Product complies with the applicable United Kingdom’s legislation (Statutory Instruments). Marking is required for products being placed on the market in Great Britain (England, Wales and Scotland).</p>
	<p>UL Listed mark for USA and Canada</p> <p>Product has been tested and evaluated against the relevant North American standards by the Underwriters Laboratories. Valid with rated voltages up to 600 V.</p>
	<p>CSA certification mark for USA and Canada</p> <p>Product has been tested and evaluated against the relevant North American standards by the CSA Group. Valid with rated voltages up to 600 V.</p>
	<p>EAC (Eurasian Conformity) mark</p> <p>Product complies with the technical regulations of the Eurasian Customs Union. EAC mark is required in Russia, Belarus and Kazakhstan.</p>



	<p>KC mark Product complies with Korean Registration of Broadcasting and Communications Equipment Clause 3, Article 58-2 of Radio Waves Act.</p>
	<p>Electronic Information Products (EIP) symbol including an Environment Friendly Use Period (EFUP). Product is compliant with the People's Republic of China Electronic Industry Standard (SJ/T 11364-2014) about hazardous substances. The EFUP is 20 years. China RoHS II Declaration of Conformity is available from <a href="https://library.abb.com">https://library.abb.com</a>.</p>
	<p>WEEE mark At the end of life the product should enter the recycling system at an appropriate collection point and not placed in the normal waste stream.</p>

## Compliance with the EN 61800-3:204 + A1:2012

### ■ Definitions

EMC stands for Electromagnetic Compatibility. It is the ability of electrical/electronic equipment to operate without problems within an electromagnetic environment. Likewise, the equipment must not disturb or interfere with any other product or system within its locality.

*First environment* includes establishments connected to a low-voltage network which supplies buildings used for domestic purposes.

*Second environment* includes establishments connected to a network not supplying domestic premises.

*Drive of category C1:* drive of rated voltage less than 1000 V and intended for use in the first environment.

*Drive of category C2:* drive of rated voltage less than 1000 V and intended to be installed and started up only by a professional when used in the first environment.

**Note:** A professional is a person or organization having necessary skills in installing and/or starting up power drive systems, including their EMC aspects.

*Drive of category C3:* drive of rated voltage less than 1000 V and intended for use in the second environment and not intended for use in the first environment.

*Drive of category C4:* drive of rated voltage equal to or above 1000 V, or rated current equal to or above 400 A, or intended for use in complex systems in the second environment.

### ■ Category C2

The emission limits are complied with the following provisions:

1. The drive is equipped with EMC filter +E202.
2. The motor and control cables are selected as specified in this manual.
3. The drive is installed according to the instructions given in this manual.
4. For the maximum motor cable length, see section *Motor connection data*.



**WARNING!** The drive may cause radio interference if used in residential or domestic environment. The user is required to take measures to prevent interference, in association to the requirements for the CE compliance listed above, if necessary.

---

**Note:** Note: Do not install a drive with the EMC filter +E202 connected to a system that the filter is not suitable for. This can cause danger, or damage the drive.

**Note:** Do not install a drive with the ground-to-phase varistor connected to a system that the varistor is not suitable for. If you do, the varistor circuit can be damaged.

If you install the drive to any other system than symmetrically grounded TN-S system, you may need to disconnect the EMC filter or the ground-to-phase varistor. See [ACS880 frames R1 to R11 EMC filter and ground-to-phase varistor disconnecting instructions \(3AUA0000125152 \[English\]\)](#).

### ■ Category C3

The drive complies with the standard with the following provisions:

- The drive is equipped with EMC filter +E200.
- The motor and control cables are selected as specified in this manual.
- The drive is installed according to the instructions given in this manual.
- For the maximum motor cable length, see section *Motor connection data*.



**WARNING!** drive of category C3 is not intended to be used on a low-voltage public network which supplies domestic premises. Radio frequency interference is expected if the drive is used on such a network.

---

**Note:** Do not install a drive with the EMC filter +E200 connected to a system that the filter is not suitable for. This can cause danger, or damage the drive.

**Note:** Do not install a drive with the ground-to-phase varistor connected to a system that the varistor is not suitable for. If you do, the varistor circuit can be damaged.

If you install the drive to any other system than symmetrically grounded TN-S system, you may need to disconnect the EMC filter or the ground-to-phase varistor. See [ACS880 frames R1 to R11 EMC filter and ground-to-phase varistor disconnecting instructions \(3AUA0000125152 \[English\]\)](#).

---

## ■ Category C4

The drive complies with the C4 category with these provisions:

1. It is made sure that no excessive emission is propagated to neighboring low-voltage networks. In some cases, the natural suppression in transformers and cables is sufficient. If in doubt, a supply transformer with static screening between the primary and secondary windings can be used.

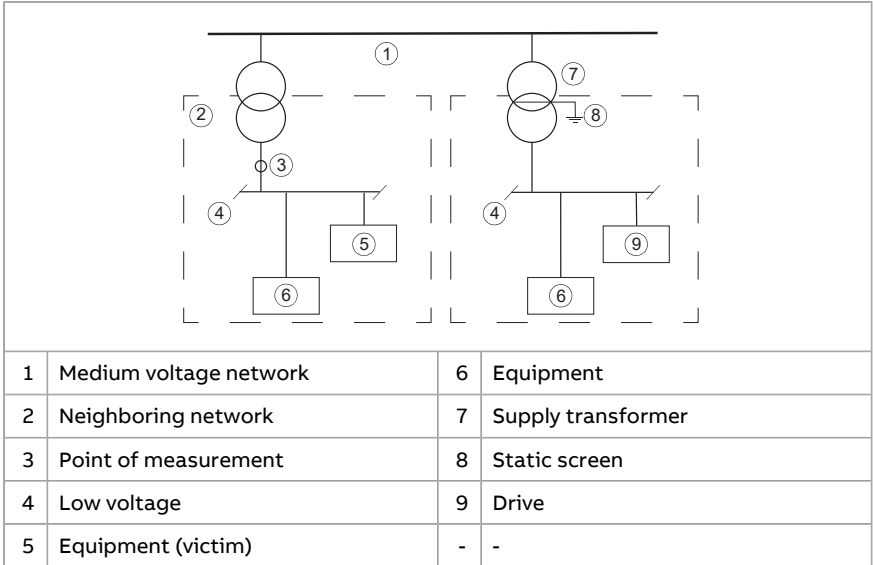

2. An EMC plan for preventing disturbances is drawn up for the installation. A template is available in [Technical guide No. 3 EMC compliant installation and configuration for a power drive system \(3AFE61348280 \[English\]\)](#).
3. The motor and control cables are selected, and routed according to the electrical planning guidelines of the drive. The EMC recommendations are obeyed.
4. The drive is installed according to its installation instructions. The EMC recommendations are obeyed.



### WARNING!

A drive of category C4 is not intended to be used on a low-voltage public network which supplies domestic premises. Radio frequency interference is expected if the drive is used on such a network.

## Declarations of conformity

See chapter [The Safe torque off function](#) (page 293).

## UL checklist

---



### WARNING!

Operation of this drive requires detailed installation and operation instructions provided in the hardware and software manuals. The manuals are provided in electronic format in the drive package or on the Internet. Keep the manuals with the drive at all times. Hard copies of the manuals can be ordered through the manufacturer.

---

- Make sure that the drive type designation label includes the applicable marking.
  - **DANGER - Risk of electric shock.** After disconnecting the input power, always wait for 5 minutes to let the intermediate circuit capacitors discharge before you start working on the drive, motor or motor cable.
  - The drive is to be used in a heated, indoor controlled environment. The drive must be installed in clean air according to the enclosure classification. Cooling air must be clean, free from corrosive materials and electrically conductive dust.
  - The maximum surrounding air temperature is 40 °C at rated output current. The output current is derated for 40...55 °C.
  - The drive is suitable for use in a circuit capable of delivering not more than 100 kA rms symmetrical amperes, 600 V maximum when protected by the UL fuses given elsewhere in this chapter.
  - The drive is suitable for use in a circuit capable of delivering not more than 65 kA rms symmetrical amperes, 600 V maximum when protected by the UL circuit breakers given elsewhere in this chapter.
  - The cables located within the motor circuit must be rated for at least 75 °C in UL-compliant installations.
  - The input cable must be protected with fuses or circuit breakers. These protective devices provide branch circuit protection in accordance with the national regulations (National Electrical Code (NEC) or Canadian Electrical Code). Obey also any other applicable local or provincial codes. Suitable UL fuses are listed in section [Fuses \(UL\)](#) (page 223) and circuit breakers in section [Circuit breakers \(UL\)](#) (page 228).
-

**WARNING!**

The opening of the branch-circuit protective device may be an indication that a fault current has been interrupted. To reduce the risk of fire or electric shock, current-carrying parts and other components of the device should be examined and replaced if damaged.

---

- The drive provides motor overload protection. The protection is not enabled when the drive leaves the ABB factory. For enabling the protection, see the firmware manual.
- The drive overvoltage category according to IEC 60664-1 is III.
- To maintain the environment integrity of the enclosure, replace the cable grommets with field-installed industrial conduit hubs or closure plates required by the enclosure type (or better).

## Approvals

The drive is marine type approved. For more information, see [ACS880-01/04 +C132 marine type-approved drives supplement \(3AXD50000010521 \[English\]\)](#).

## Design lifetime expectancy

The design lifetime expectancy of the drive and its overall components exceeds ten (10) years in normal operating environments. In some cases, the drive can last 20 years or more. To achieve a long lifetime for the product the manufacturer's instructions for sizing the drive, installation, operational conditions and preventive maintenance schedule shall be followed.

## Disclaimers

### ■ Generic disclaimer

The manufacturer shall have no obligation with respect to any product which (i) has been improperly repaired or altered; (ii) has been subjected to misuse, negligence or accident; (iii) has been used in a manner contrary to the manufacturer's instructions; or (iv) has failed as a result of ordinary wear and tear.

### ■ Cybersecurity disclaimer

This product can be connected to and communicate information and data via a network interface. The HTTP protocol, which is used between the commissioning tool (Drive Composer) and the product, is an unsecured protocol. For independent and continuous operation of product such connection via network to commissioning tool is not necessary. However it is Customer's sole responsibility to provide and continuously ensure a secure connection between the product and Customer network or any other network (as the case may be). Customer shall

---

establish and maintain any appropriate measures (such as but not limited to the installation of firewalls, prevention of physical access, application of authentication measures, encryption of data, installation of anti-virus programs, etc.) to protect the product, the network, its system and the interface against any kind of security breaches, unauthorized access, interference, intrusion, leakage and/or theft of data or information.

Notwithstanding any other provision to the contrary and regardless of whether the contract is terminated or not, ABB and its affiliates are under no circumstances liable for damages and/or losses related to such security breaches, any unauthorized access, interference, intrusion, leakage and/or theft of data or information.

---

# 14

## Dimension drawings

---

### Contents of this chapter

This chapter contains dimension drawings of the standard drive (IP21, UL Type 1) and drive with option +B056 (IP55, UL Type 12).

For dimension drawings with options +P940 and +P944 (IP20, UL Open Type), see [ACS880...+P940 and +P944 drive modules supplement \(3AUA0000145446 \[English\]\)](#).

---

# Frame R1 (IP21, UL Type 1)

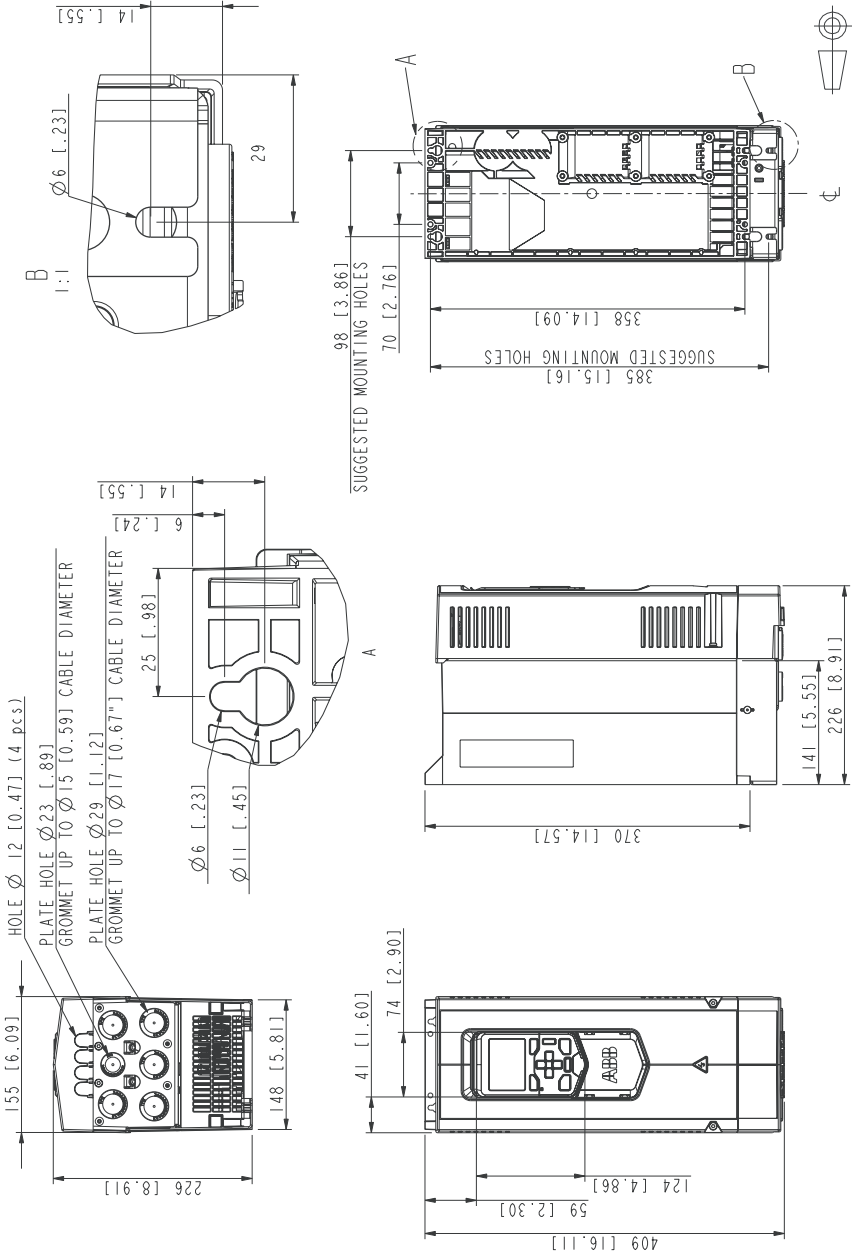



# Frame R1 (IP55, UL Type 12)

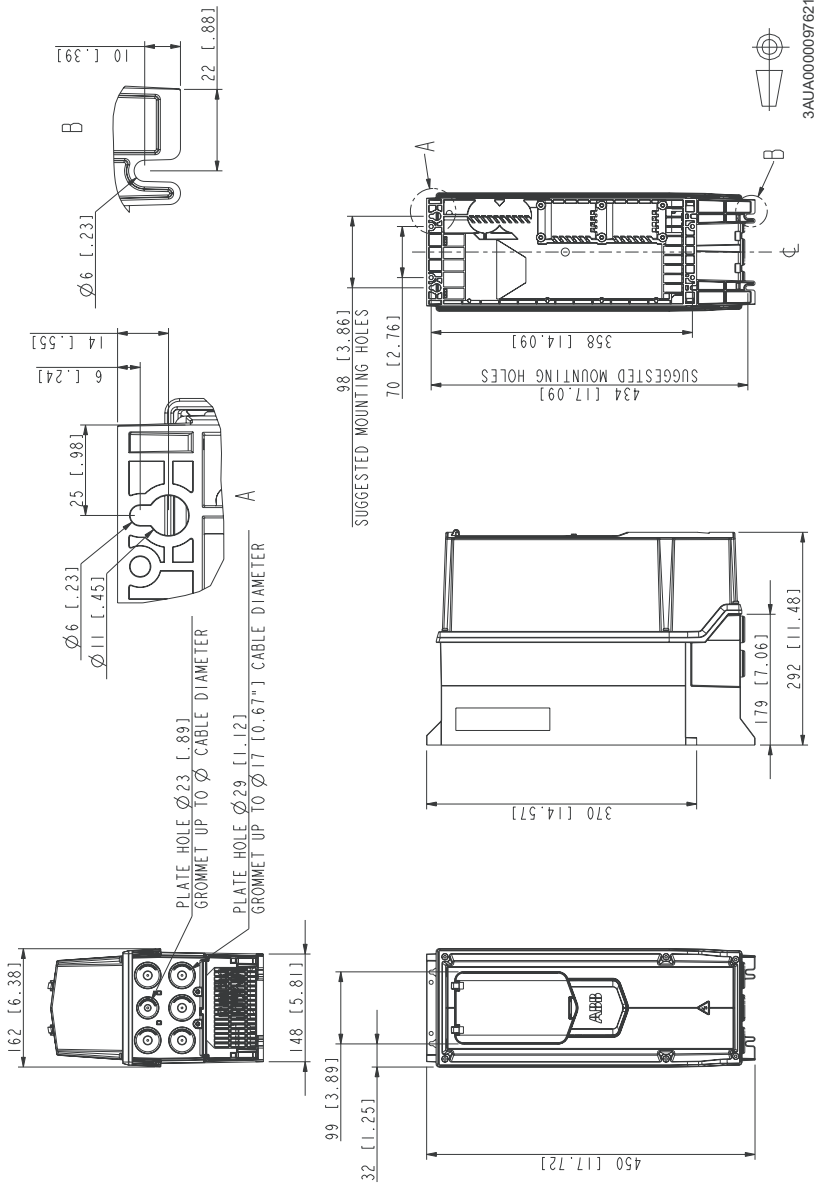

# Frame R2 (IP21, UL Type 1)

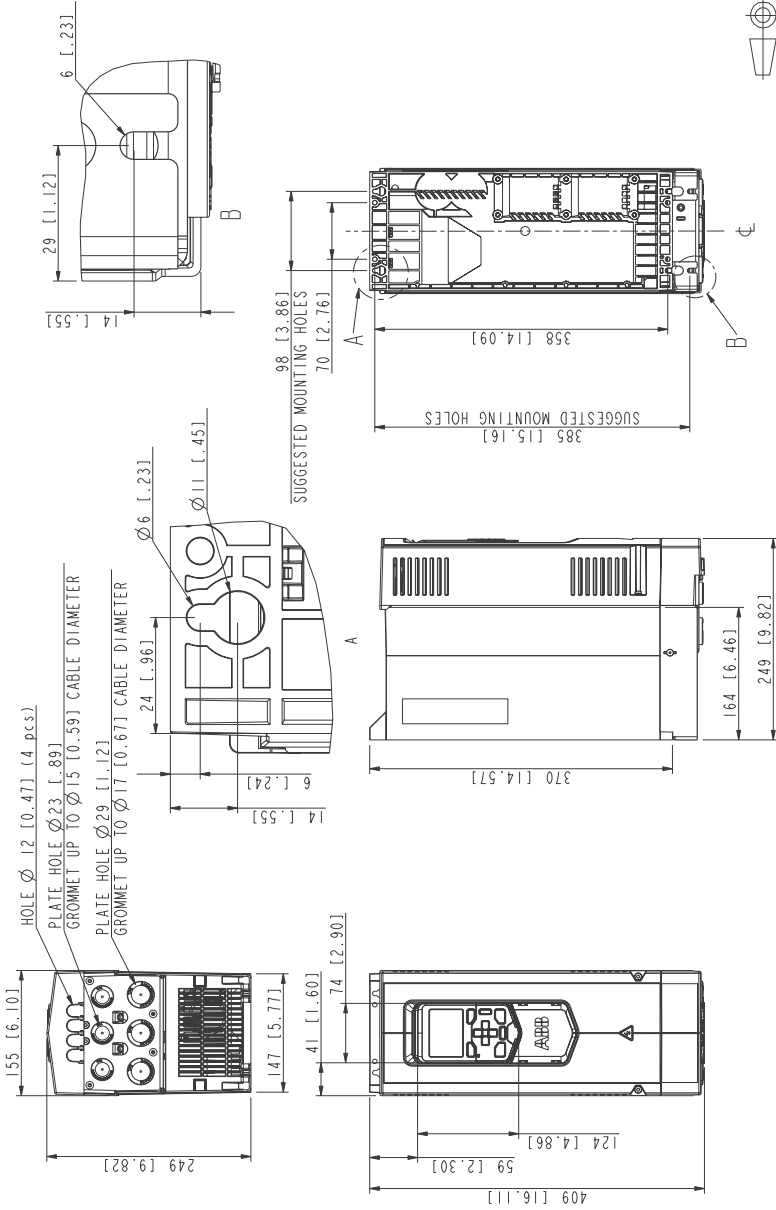

# Frame R2 (IP55, UL Type 12)

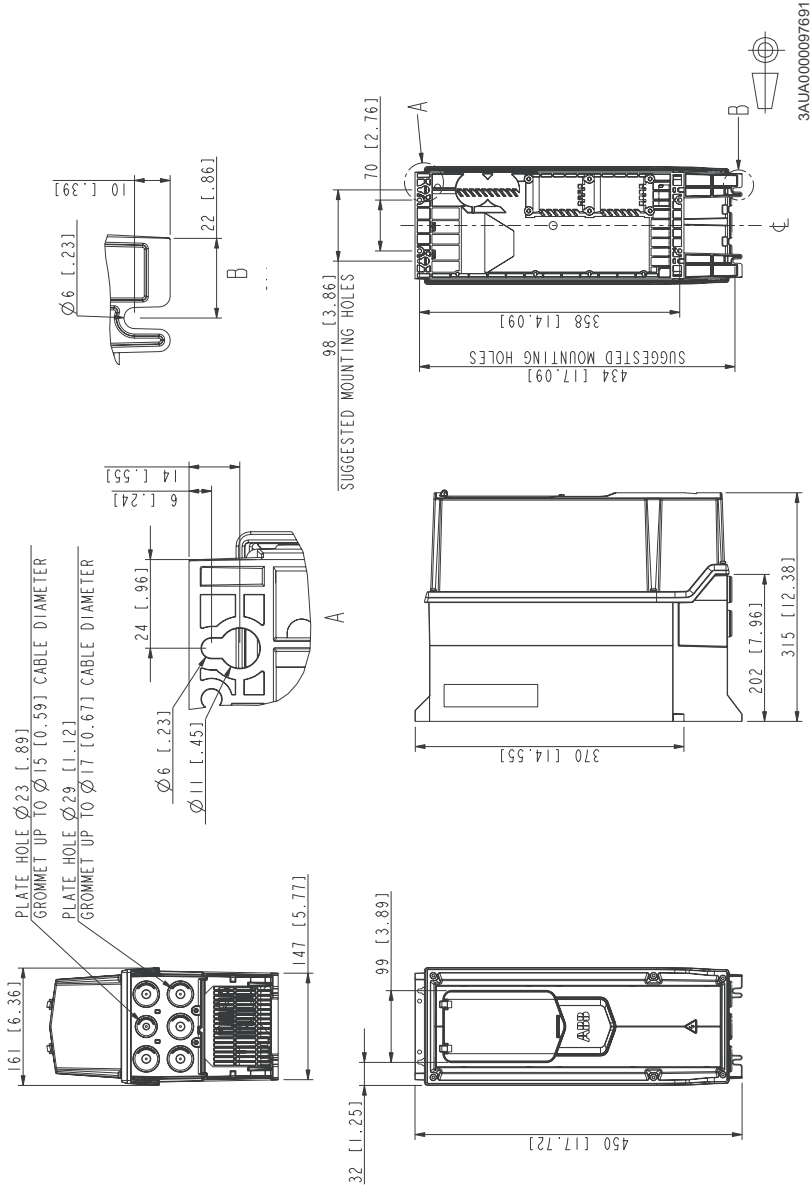

# Frame R3 (IP21, UL Type 1)

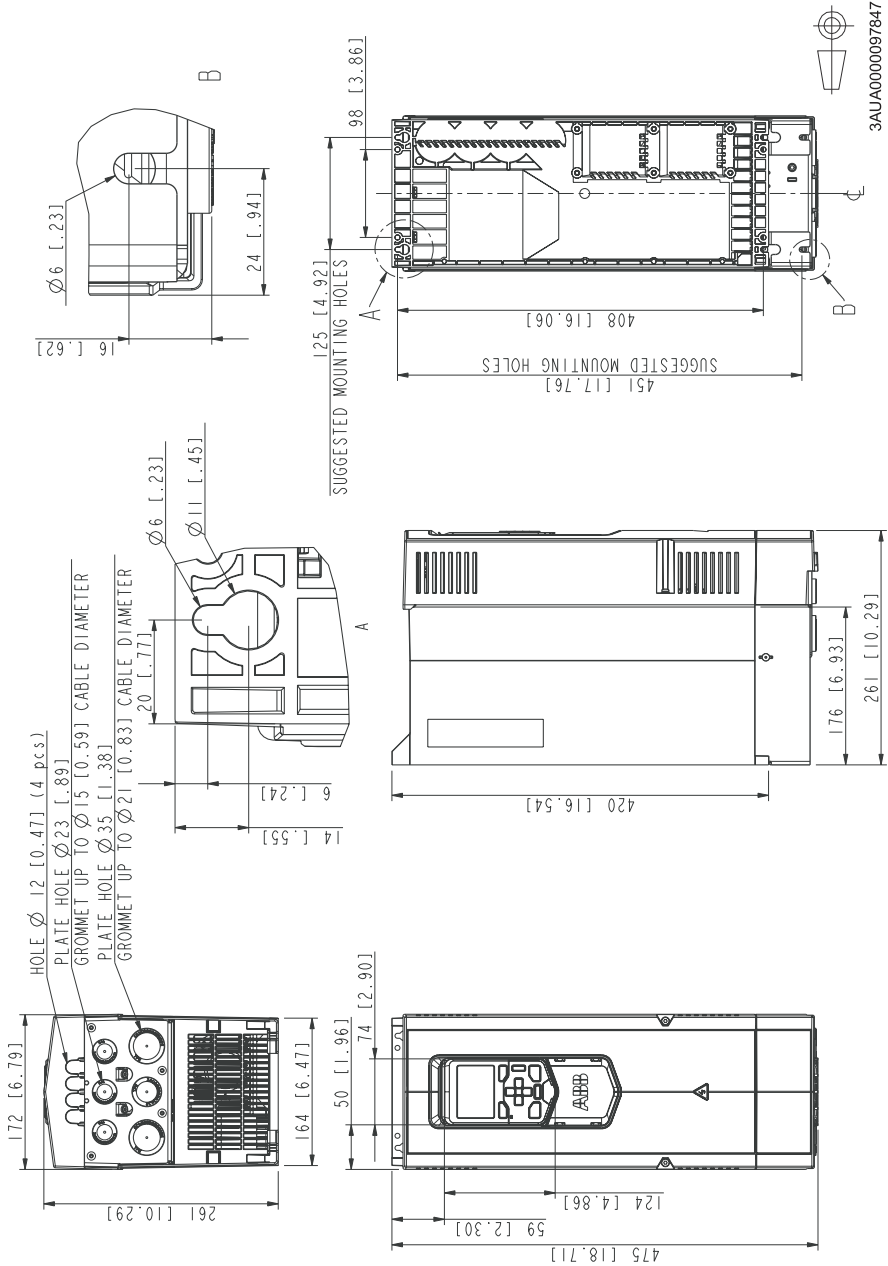

# Frame R3 (IP55, UL Type 12)

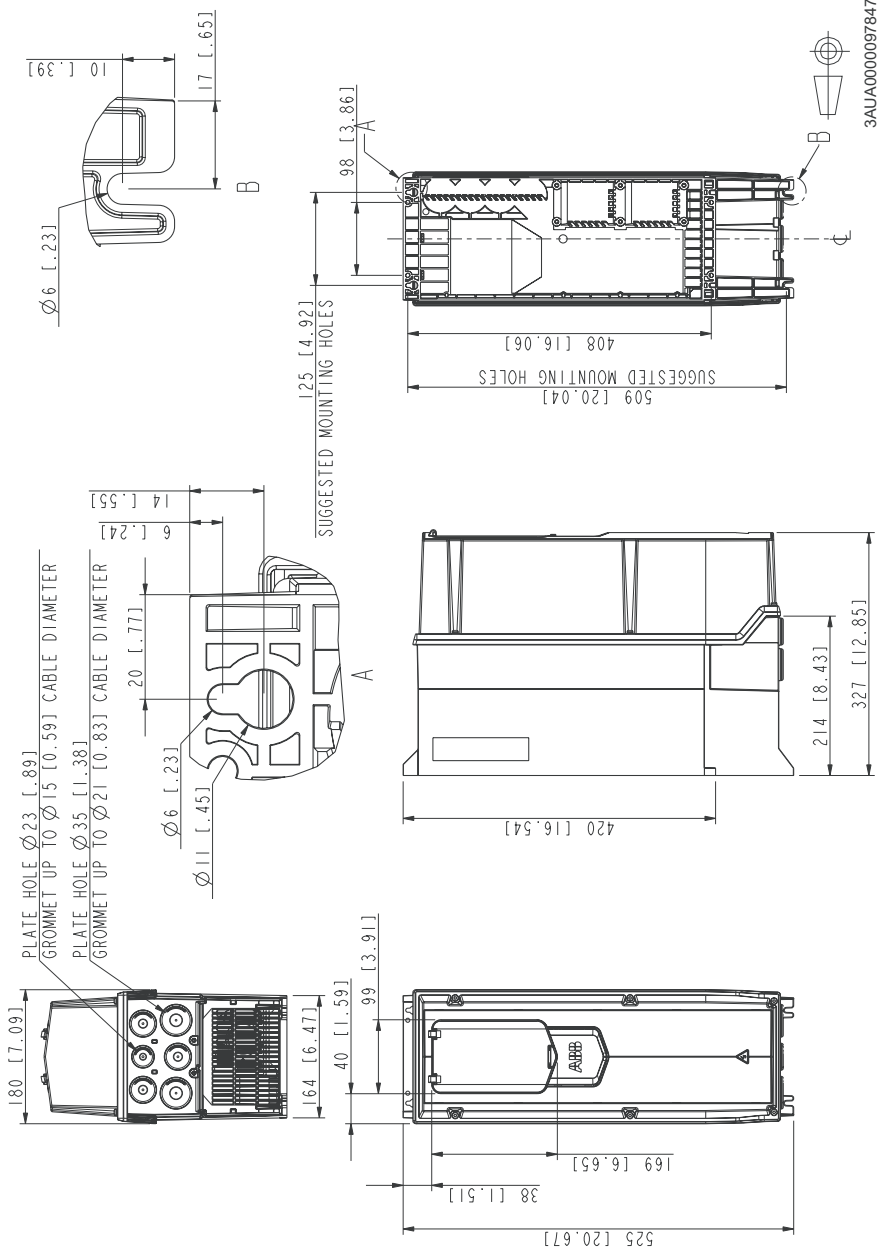

# Frame R4 (IP21, UL Type 1)

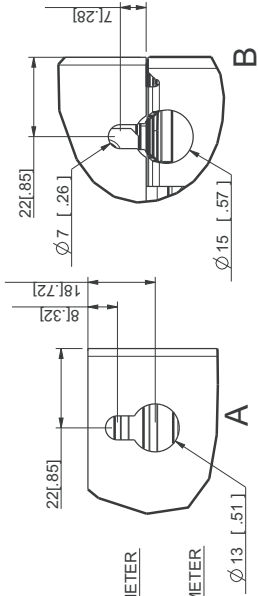
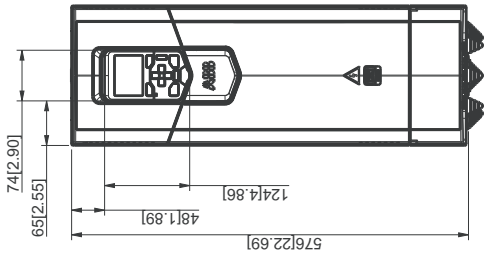
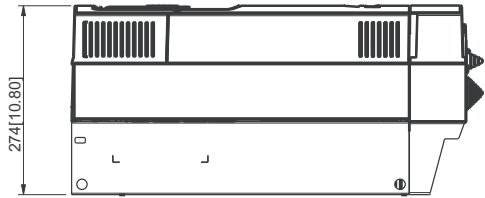
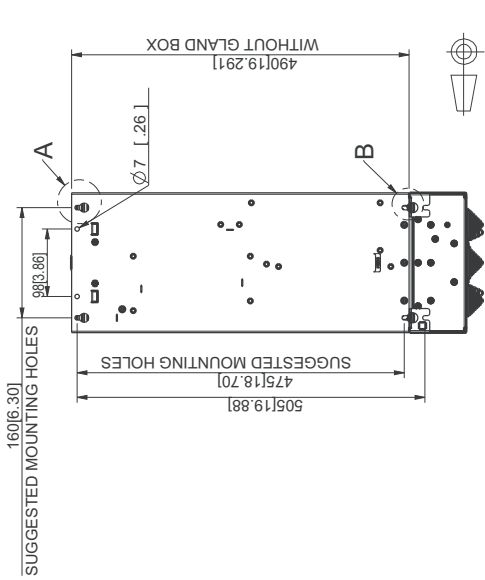
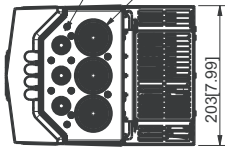

PLATE HOLE  $\varnothing 22$  [0.87] (3pcs.)  
GROMMET UP TO  $\varnothing 15$  [0.59] CABLE DIAMETER

PLATE HOLE  $\varnothing 44$  [1.73] (3pcs.)  
GROMMET UP TO  $\varnothing 24$  [0.94] CABLE DIAMETER



3AUUA000098285

# Frame R4 (IP55, UL Type 12)

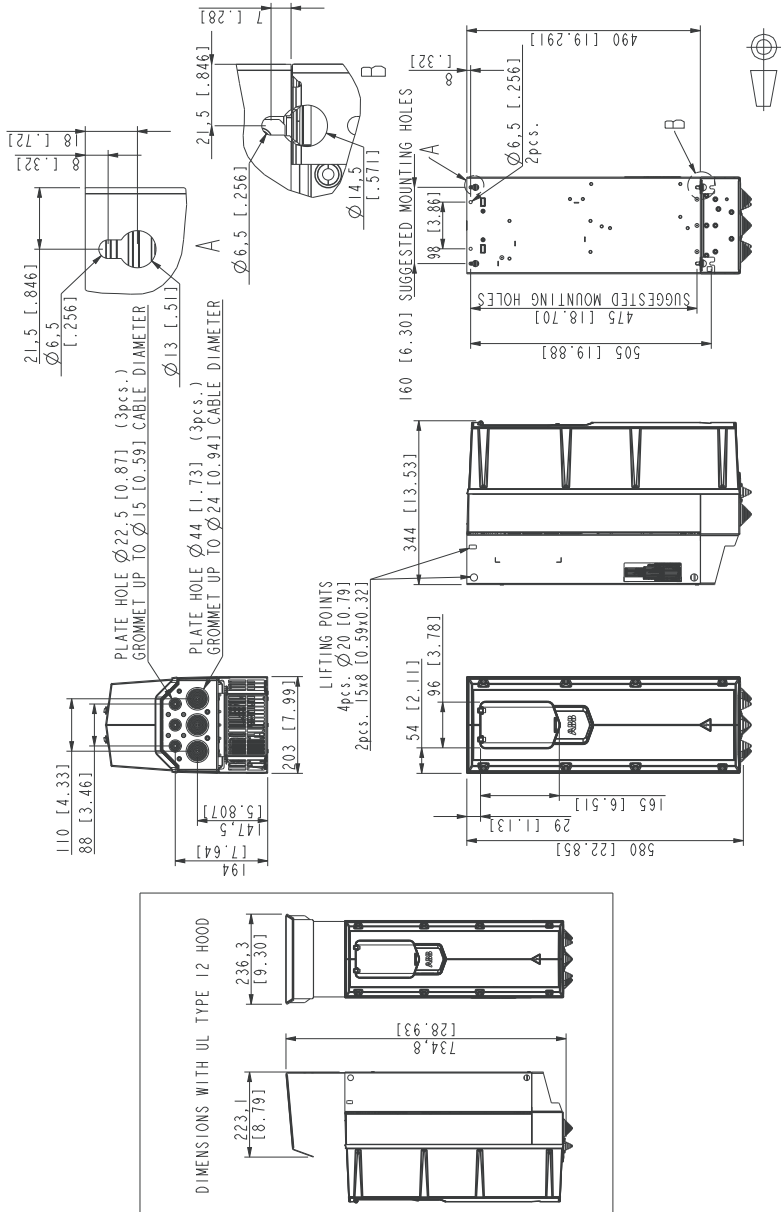

3AUUA000098285

# Frame R5 (IP21, UL Type 1)

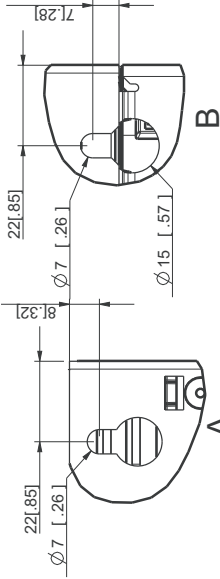
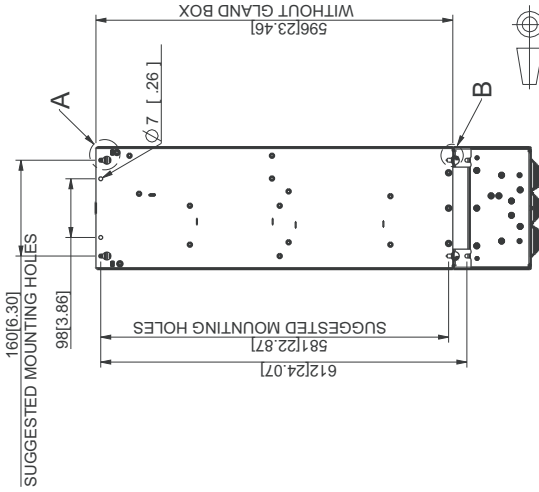
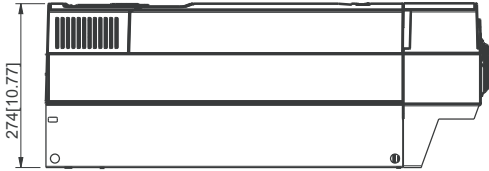
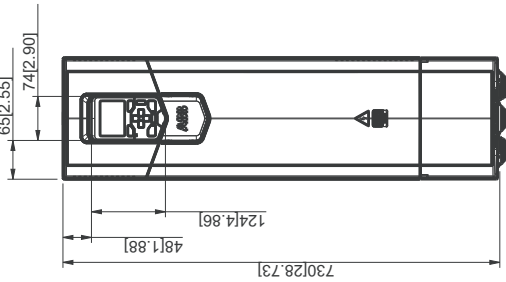
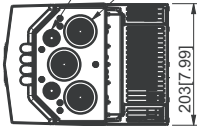

PLATE HOLE  $\varnothing 29$  [1.12] (2pcs.)  
 GROMMET UP TO  $\varnothing 22$  [0.87] CABLE DIAMETER  
 PLATE HOLE  $\varnothing 51$  [2.01] (3pcs.)  
 GROMMET UP TO  $\varnothing 32$  [1.26] CABLE DIAMETER



3AUAA000097965



# Frame R5 (IP55, UL Type 12)

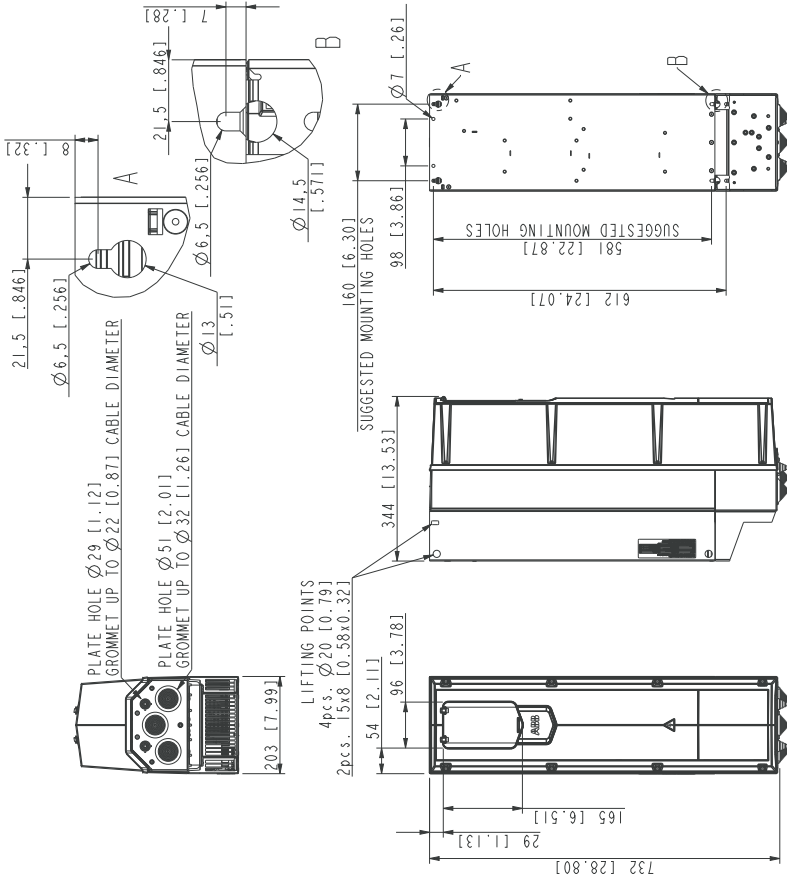

3AUA00000979x65

# Frame R6 (IP21, UL Type 1)

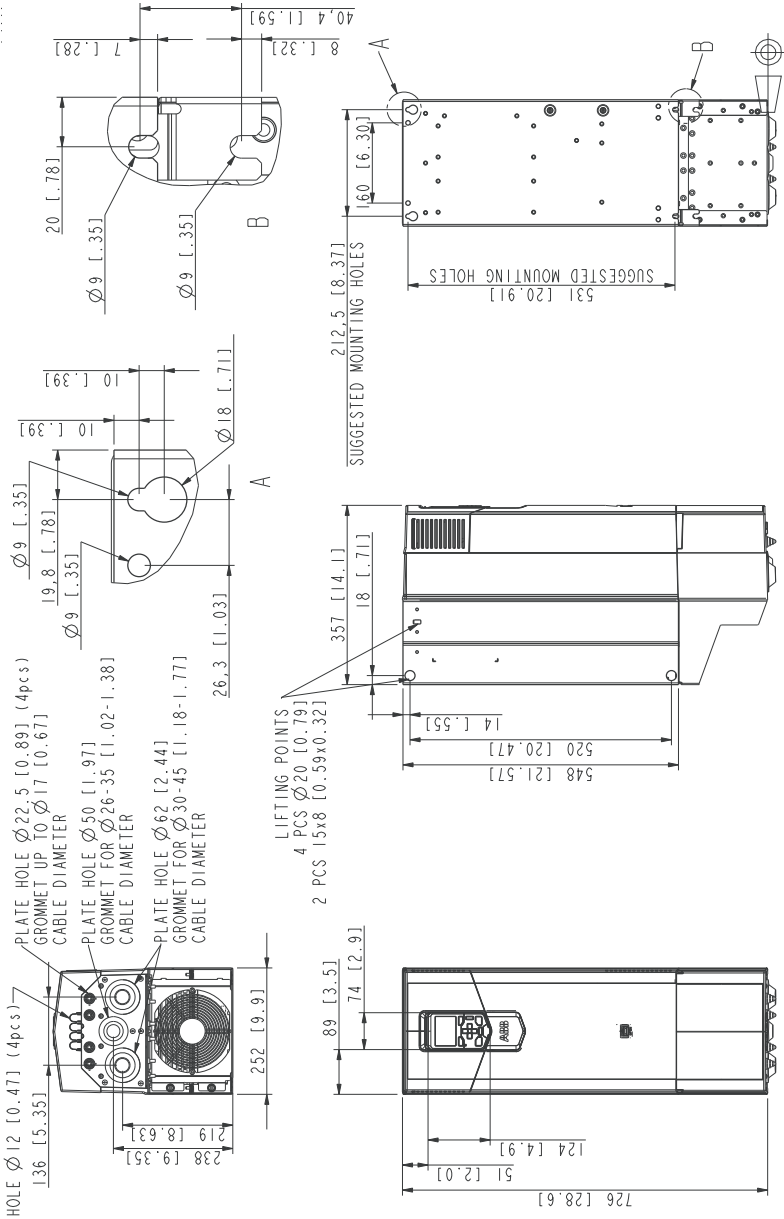

3AUA0000098321

# Frame R6 (IP55, UL Type 12)

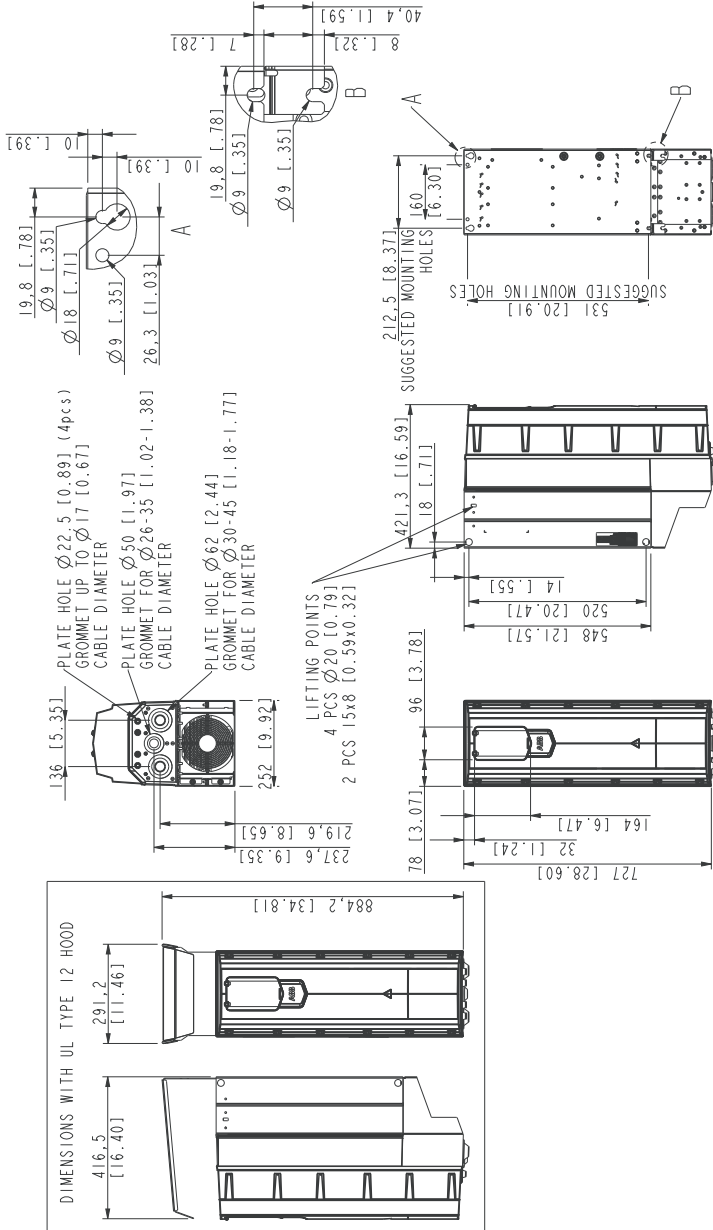

3AUA0000098321

# Frame R7 (IP21, UL Type 1)

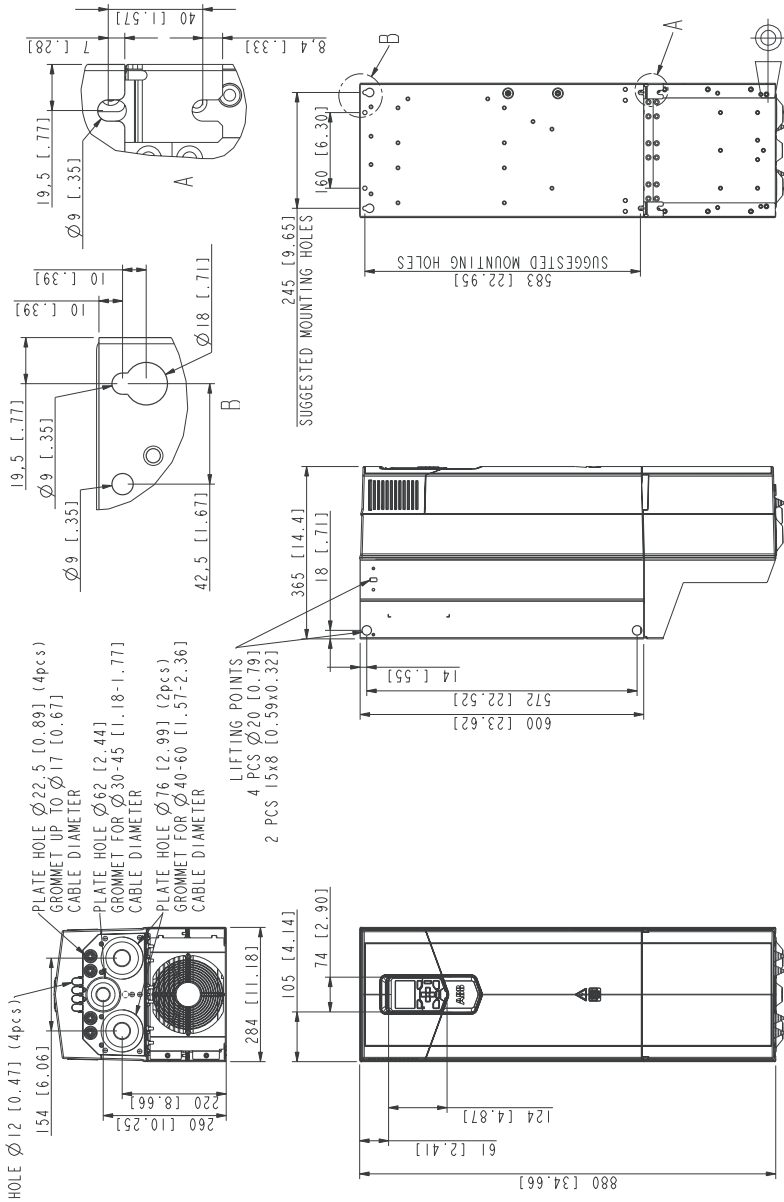

# Frame R7 (IP55, UL Type 12)

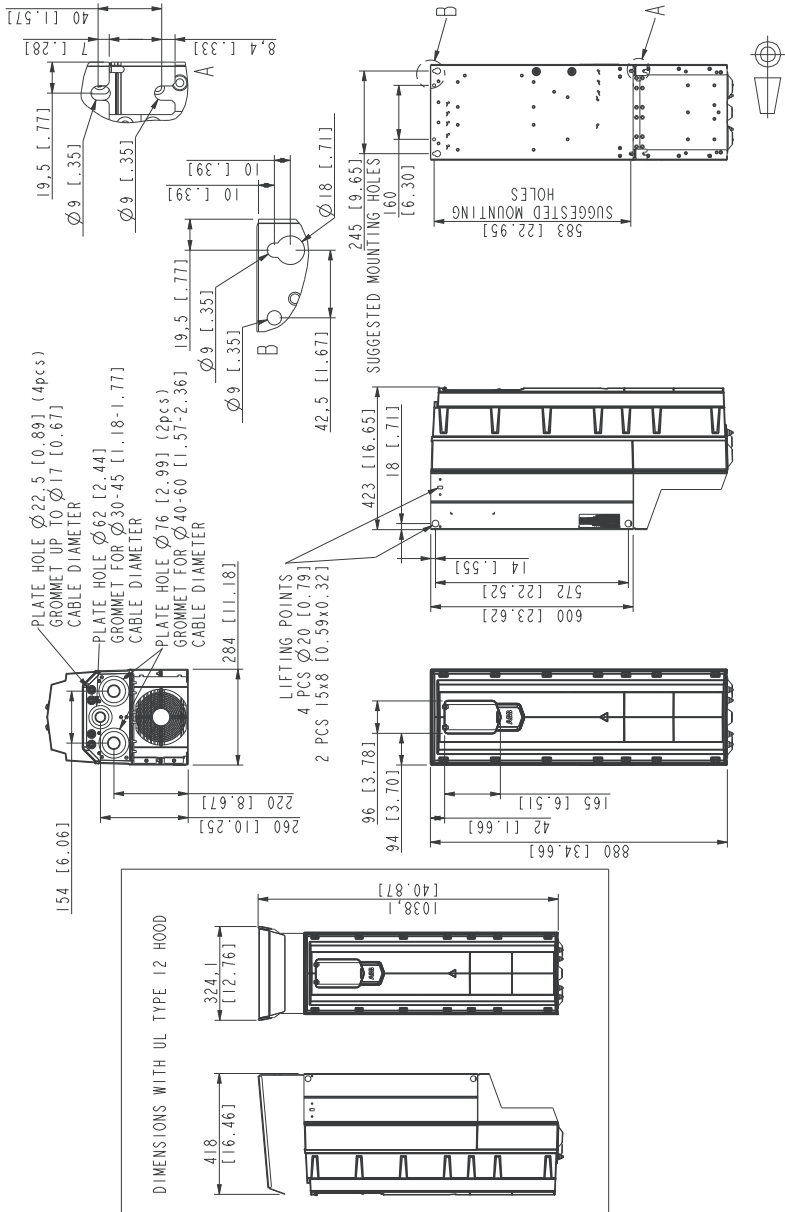

3AUUA0000073149

# Frame R8 (IP21, UL Type 1)

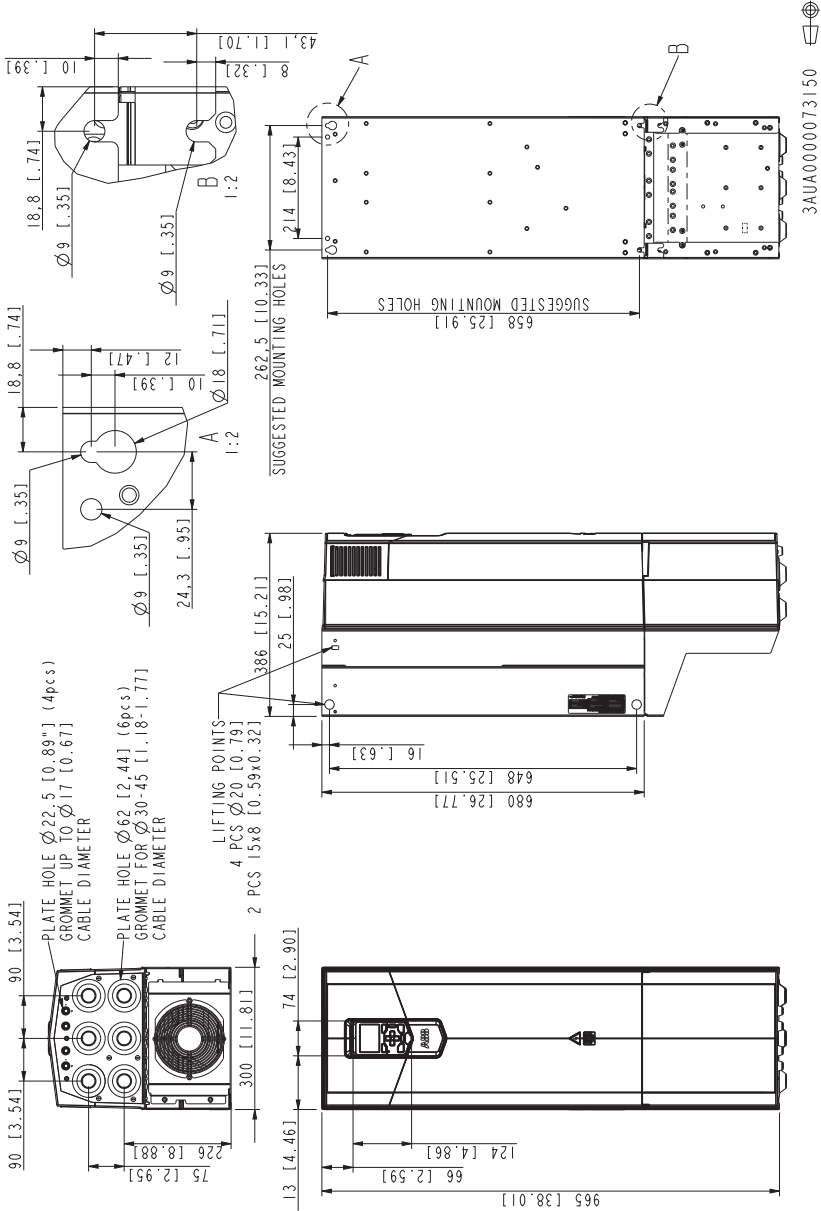



# Frame R9 (IP21, UL Type 1)

3AUUA0000073151

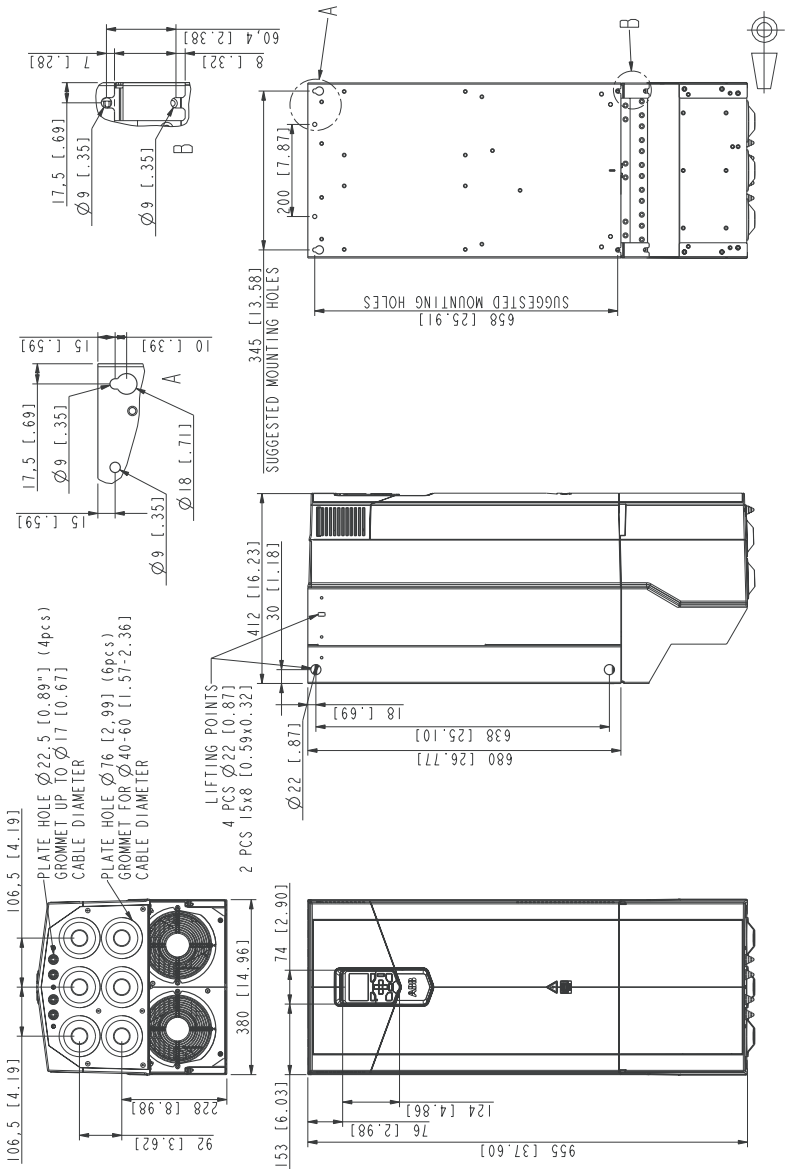







# 15

## Resistor braking

---

### Contents of this chapter

This chapter describes how to select, protect and wire brake choppers and resistors. The chapter also contains technical data.

### Operation principle and hardware description

Frames R1 to R4 have a built-in brake chopper as standard. Frames R5 and up can be equipped with optional built-in brake chopper (+D150). Brake resistors are available as add-on kits.

The brake chopper handles the energy generated by a decelerating motor. The extra energy increases the DC link voltage. The chopper connects the brake resistor to the intermediate DC circuit whenever the voltage in the circuit exceeds the limit defined by the control program. Energy consumption by the resistor losses lowers the voltage until the resistor can be disconnected.

### Planning the braking system

#### ■ Selecting the brake circuit components

1. Calculate the maximum power generated by the motor during braking ( $P_{\max}$ ).
  2. Select a suitable drive, brake chopper and brake resistor combination for the application from the rating table in this chapter. The braking power of the chopper must be greater or equal than the maximum power generated by the motor during the braking.
  3. Check the resistor selection. The energy generated by the motor during a 400-second period must not exceed the resistor heat dissipation capacity  $E_R$ .
-

**Note:** If the  $E_R$  value is not sufficient, it is possible to use a four-resistor assembly in which two standard resistors are connected in parallel, two in series. The  $E_R$  value of the four-resistor assembly is four times the value specified for the standard resistor.

■ **Selecting a custom resistor**

If you use a resistor other than the default resistor,

1. make sure that the resistance of the custom resistor is greater or equal than the resistance of the default resistor in the rating table:

$R \geq R_{min}$	
$R$	Resistance of the custom resistor   <b>WARNING!</b> Never use a brake resistor with a resistance smaller than $R_{min}$ . The drive and the chopper are not able to handle the overcurrent caused by the low resistance.
$R_{min}$	Resistance of the default resistor

2. make sure that the load capacity of the custom resistor is greater than the instantaneous maximum power consumption of the resistor when it is connected to the drive DC link voltage by the chopper:

$P_r < (U_{DC}^2)/R$														
$P_r$	Load capacity of the custom resistor   <b>WARNING!</b> Never use a brake resistor with a resistance smaller than $R_{min}$ . The drive and the chopper are not able to handle the overcurrent caused by the low resistance.													
$U_{DC}$	Drive DC link voltage during braking													
	<table border="1"> <tr> <td>Supply voltage range (V AC)</td> <td>208..240</td> <td>380..415</td> <td>440..480</td> <td>500</td> <td>525..600</td> <td>660..690</td> </tr> <tr> <td>Drive DC link voltage during braking (V DC) when internal brake chopper at 100% pulse width</td> <td>403</td> <td>697</td> <td>806</td> <td>806</td> <td>1008</td> <td>1159</td> </tr> </table>	Supply voltage range (V AC)	208..240	380..415	440..480	500	525..600	660..690	Drive DC link voltage during braking (V DC) when internal brake chopper at 100% pulse width	403	697	806	806	1008
Supply voltage range (V AC)	208..240	380..415	440..480	500	525..600	660..690								
Drive DC link voltage during braking (V DC) when internal brake chopper at 100% pulse width	403	697	806	806	1008	1159								
See <a href="#">ACS880 primary control program Firmware manual (3AUA0000085967 [English])</a> for more information.														
$R$	Resistance of the custom resistor													

## ■ Selecting and routing the brake resistor cables

Use the same cable type for the resistor cabling as for the drive input cabling to ensure that the input fuses also protect the resistor cable. Alternatively, a two conductor shielded cable with the same cross-sectional area can be used.

## ■ Minimizing electromagnetic interference

Follow these rules in order to minimize electromagnetic interference caused by the rapid current changes in the resistor cables:

- Shield the braking power line completely, either by using shielded cable or a metallic enclosure. Unshielded single-core cable can only be used if it is routed inside a cabinet that efficiently suppresses the radiated emissions.
- Install the cables away from other cable routes.
- Avoid long parallel runs with other cables. The minimum parallel cabling separation distance should be 0.3 meters.
- Cross the other cables at right angles.
- Keep the cable as short as possible in order to minimize the radiated emissions and stress on chopper IGBTs. The longer the cable the higher the radiated emissions, inductive load and voltage peaks over the IGBT semiconductors of the brake chopper.

## ■ Maximum cable length

The maximum length of the resistor cable(s) is 10 m (33 ft).

## ■ EMC compliance of the complete installation

ABB has not verified that the EMC requirements are fulfilled with external user-defined brake resistors and cabling. The EMC compliance of the complete installation must be considered by the customer.

## ■ Placing the brake resistors

Install the resistors outside the drive in a place where they will cool.

Arrange the cooling of the resistor in a way that:

- no danger of overheating is caused to the resistor or nearby materials
- the temperature of the room the resistor is located in does not exceed the allowed maximum.

Supply the resistor with cooling air/water according to the resistor manufacturer's instructions.

---



**WARNING!** The materials near the brake resistor must be non-flammable. The surface temperature of the resistor is high. Air flowing from the resistor is of hundreds of degrees Celsius. If the exhaust vents are connected to a ventilation system, ensure that the material withstands high temperatures. Protect the resistor against contact.

---

### ■ Protecting the system against thermal overload

The brake chopper protects itself and the resistor cables against thermal overload when the cables are dimensioned according to the nominal current of the drive. The drive control program includes a resistor and resistor cable thermal protection function which can be tuned by the user. See the firmware manual.

### Protecting the system in fault situations

#### Frames R1 to R4

The drive has a brake thermal model which protects the brake resistor against overload. ABB recommends to enable the thermal model at start up.

ABB recommends to equip the drive with a main contactor for safety reasons even when you have enabled the resistor thermal model. Wire the contactor so that it opens in case the resistor overheats. This is essential for safety since the drive will not otherwise be able to interrupt the main supply if the chopper remains conductive in a fault situation. An example wiring diagram is shown below. ABB recommends that you use resistors equipped with a thermal switch (1) inside the resistor assembly. The switch indicates overtemperature.

---

ABB recommends that you also wire the thermal switch to a digital input of the drive, and configure the input to cause a fault trip at resistor overtemperature indication.

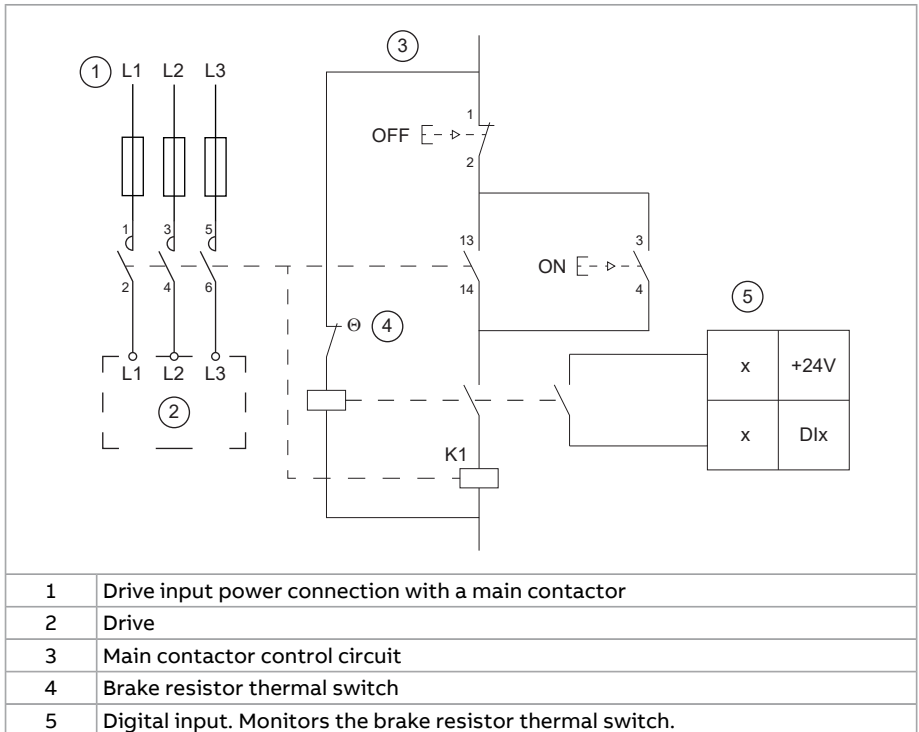

### Frames R5 to R9

A main contactor is not required for protecting against resistor overheating when the resistor is dimensioned according to the instructions and the internal brake chopper is in use. The drive will disable power flow through the input bridge if the chopper remains conductive in a fault situation but the charging resistor may fail.

**Note:** If an external brake chopper (outside the drive module) is used, a main contactor is always required.

A thermal switch (standard in ABB resistors) is required for safety reasons. The thermal switch cable must be shielded and may not be longer than the resistor cable. Wire the switch to a digital input on the drive control unit as shown in the figure below.

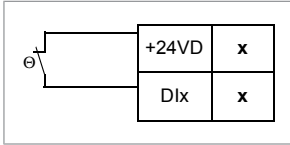

### Protecting the resistor cable against short-circuits

The input fuses will also protect the resistor cable when it is identical with the input cable.

## Mechanical installation

Brake resistors must be installed outside the drive. Obey the resistor manufacturer's instructions.

## Electrical installation

### ■ Measuring the insulation of the assembly

See section [Measuring the insulation resistance of the brake resistor circuit](#) (page 97)

### ■ Connection diagram

See section [Connection diagram](#) (page 99).

### ■ Connection procedure

- Connect the resistor cables to the R+ and R- terminals in the same way as the other power cables. If a shielded three-conductor cable is used, cut the third conductor, insulate it, and ground the twisted shield of the cable (protective earth conductor of the resistor assembly) at both ends.
- Connect the thermal switch of the brake resistor as described above in section [Frames R1 to R4](#) (page 282) or [Frames R5 to R9](#) (page 283).

## Start-up

**Note:** New brake resistors may be coated with storage grease. As the brake chopper operates for the first time, the grease burns off and may produce some smoke. Make sure there is sufficient ventilation.

Set the following parameters (ACS880 primary control program):

- Disable the overvoltage control of the drive by parameter 30.30 Overvoltage control.
  - Set parameter 31.01 External event 1 source to point to the digital input where the thermal switch of the brake resistor is wired.
-



- Set parameter 31.02 External event 1 type to Fault.
- Enable the brake chopper by parameter 43.06 Brake chopper enable. If Enabled with thermal model is selected, set also the brake resistor overload protection parameters 43.08 and 43.09 according to the application.
- For frames R5 to R9: Set parameter 43.07 Brake chopper runtime enable to Other [bit] and select from parameter 10.01 DI status the digital input where the thermal switch of the brake resistor is wired.
- Check the resistance value of parameter 43.10 Brake resistance.

With these parameter settings, the drive stops by coasting on brake resistor overtemperature.



### WARNING!

If the drive is equipped with a brake chopper but the chopper is not enabled by the parameter setting, the internal thermal protection of the drive against resistor overheating is not in use. In this case, the brake resistor must be disconnected.

For settings of other control programs, see the appropriate firmware manual.

## Technical data

### ■ Ratings

ACS880-01-...	Internal brake chopper		Example brake resistor(s)			
	$P_{Rcont}$	$R_{min}$	Type	R	$E_R$	$P_{Rcont}$
	kW	ohm		ohm	kJ	kW
$U_n = 230\text{ V}$						
04A6-2	0.75	65	JBR-03	80	40	0.14
06A6-2	1.1	65	JBR-03	80	40	0.14
07A5-2	1.5	65	JBR-03	80	40	0.14
10A6-2	2.2	65	JBR-03	80	40	0.14
16A8-2	4.0	18	SACE15RE22	22	420	2
24A3-2	5.5	18	SACE15RE22	22	420	2
031A-2	7.5	13	SACE15RE13	13	435	2
046A-2	11	12	SACE15RE13	13	435	2
061A-2	11	12	SACE15RE13	13	435	2
075A-2	18.5	6	SAFUR90F575	8	1800	4.5
087A-2	22	6	SAFUR90F575	8	1800	4.5
115A-2	30	3.5	SAFUR125F500	4	3600	9
145A-2	37	3.5	SAFUR125F500	4	3600	9

## 286 Resistor braking

ACS880-01-...	Internal brake chopper		Example brake resistor(s)			
	$P_{brcont}$	$R_{min}$	Type	R	$E_R$	$P_{Rcont}$
	kW	ohm		ohm	kJ	kW
170A-2	45	2.4	SAFUR200F500	2.7	5400	13.5
206A-2	55	2.4	SAFUR200F500	2.7	5400	13.5
274A-2	75	1.8	SAFUR200F500	2.7	5400	13.5
$U_n = 400\text{ V}$						
02A4-3	0.75	78	JBR-03	80	40	0.14
03A3-3	1.1	78	JBR-03	80	40	0.14
04A0-3	1.5	78	JBR-03	80	40	0.14
05A6-3	2.2	78	JBR-03	80	40	0.14
07A2-3	3.0	78	JBR-03	80	40	0.14
09A4-3	4.0	78	JBR-03	80	40	0.14
12A6-3	5.5	78	JBR-03	80	40	0.14
017A-3	7.5	39	SACE08RE44	44	210	1
025A-3	11	39	SACE08RE44	44	210	1
032A-3	15	19	SACE15RE22	22	420	2
038A-3	18.5	19	SACE15RE22	22	420	2
045A-3	22	13	SACE15RE13	13	435	2
061A-3	22	13	SACE15RE13	13	435	2
072A-3	37	8	SAFUR90F575	8	1800	4.5
087A-3	45	8	SAFUR90F575	8	1800	4.5
105A-3	55	5.4	SAFUR80F500	6	2400	6
145A-3	75	5.4	SAFUR80F500	6	2400	6
169A-3	90	3.3	SAFUR125F500	4	3600	9
206A-3	110	3.3	SAFUR125F500	4	3600	9
246A-3	132	2.3	SAFUR200F500	2.7	5400	13.5
293A-3	132	2.3	SAFUR200F500	2.7	5400	13.5
363A-3	160	2.0	SAFUR200F500	2.7	5400	13.5
430A-3	160	2.0	SAFUR200F500	2.7	5400	13.5
$U_n = 500\text{ V}$						
02A1-5	0.75	78	JBR-03	80	40	0.14
03A0-5	1.1	78	JBR-03	80	40	0.14
03A4-5	1.5	78	JBR-03	80	40	0.14
04A8-5	2.2	78	JBR-03	80	40	0.14
05A2-5	3.0	78	JBR-03	80	40	0.14
07A6-5	4.0	78	JBR-03	80	40	0.14
11A0-5	5.5	78	JBR-03	80	40	0.14
014A-5	7.5	39	SACE08RE44	44	210	1
021A-5	11	39	SACE08RE44	44	210	1

ACS880-01-...	Internal brake chopper		Example brake resistor(s)			
	$P_{brcont}$	$R_{min}$	Type	R	$E_R$	$P_{Rcont}$
	kW	ohm		ohm	kJ	kW
027A-5	15	19	SACE15RE22	22	420	2
034A-5	18.5	19	SACE15RE22	22	420	2
040A-5	22	13	SACE15RE13	13	435	2
052A-5	22	13	SACE15RE13	13	435	2
065A-5	37	8	SAFUR90F575	8	1800	4.5
077A-5	45	8	SAFUR90F575	8	1800	4.5
096A-5	55	5.4	SAFUR80F500	6	2400	6
124A-5	75	5.4	SAFUR80F500	6	2400	6
156A-5	90	3.3	SAFUR125F500	4	3600	9
180A-5	110	3.3	SAFUR125F500	4	3600	9
240A-5	132	2.3	SAFUR200F500	2.7	5400	13.5
260A-5	132	2.3	SAFUR200F500	2.7	5400	13.5
302A-5	160	2.3	SAFUR200F500	2.7	5400	13.5
361A-5	160	2.3	SAFUR200F500	2.7	5400	13.5
414A-5	160	2.3	SAFUR200F500	2.7	5400	13.5
$U_n = 690\text{ V}$						
07A4-7	5.5	44	SACE08RE44	44	210	1
09A9-7	7.5	44	SACE08RE44	44	210	1
14A3-7	11.0	44	SACE08RE44	44	210	1
019A-7	15.0	44	SACE08RE44	44	210	1
023A-7	18.5	44	SACE08RE44	44	210	1
027A-7	22.0	44	SACE08RE44	44	210	1
07A3-7	6	18	SACE08RE44	44	210	1
09A8-7	8	18	SACE08RE44	44	210	1
14A2-7	11	18	SACE08RE44	44	210	1
018A-7	17	18	SACE15RE22	22	420	2
022A-7	23	18	SACE15RE22	22	420	2
026A-7	28	18	SACE15RE22	22	420	2
035A-7	33	18	SACE15RE22	22	420	2
042A-7	45	18	SACE15RE22	22	420	2
049A-7	45	18	SACE15RE22	22	420	2
061A-7	55	13	SACE15RE13	13	435	2
084A-7	65	13	SACE15RE13	13	435	2
098A-7	90	8	SAFUR90F575	8	1800	4.5
119A-7	110	8	SAFUR90F575	8	1800	4.5
142A-7	132	6	SAFUR80F500	6	2400	6
174A-7	160	6	SAFUR80F500	6	2400	6

## 288 Resistor braking

ACS880-01-...	Internal brake chopper		Example brake resistor(s)			
	$P_{brcont}$	$R_{min}$	Type	R	$E_R$	$P_{Rcont}$
	kW	ohm		ohm	kJ	kW
210A-7	200	4	SAFUR125F500	4	3600	9
271A-7	250	4	SAFUR125F500	4	3600	9

$P_{brcont}$  Maximum continuous braking power. The braking is considered continuous if the braking time exceeds 30 seconds.

$R_{min}$  Minimum allowed resistance value of the brake resistor

R Resistance value for the listed resistor assembly

$E_R$  Short energy pulse that the resistor assembly withstands every 400 seconds

$P_{Rcont}$  Continuous power (heat) dissipation of the resistor when placed correctly

### ■ Degree of protection and thermal constant of the resistor

Resistor type	Degree of protection	Thermal constant (s)
JBR-03	IP20	
SACE	IP21	200
SAFUR	IP00	555



## 290 Resistor braking

<b>JBR-03 brake resistor</b>	
Dimension B	200 mm (7.87 in)
Dimension C	170 mm (6.69 in)
Weight	0.8 kg (1.8 lb)
Maximum wire size of main terminals	10 mm <sup>2</sup> (AWG6)
Tightening torque of main terminals	1.5 ... 1.8 N·m (13 ... 16 lbf·in)
Wire size of thermal switch terminals	4 mm <sup>2</sup> (AWG12)
Tightening torque of thermal switch terminals	0.6 ... 0.8 N·m (5.3 ... 7.1 lbf·in)

### ■ SACE08RE44

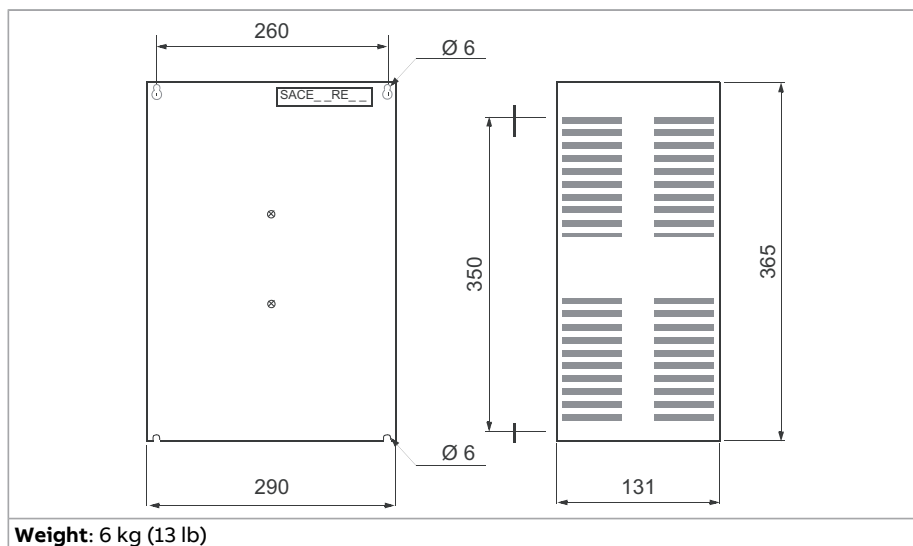

■ **SACE15RE13 and SACE15RE2**

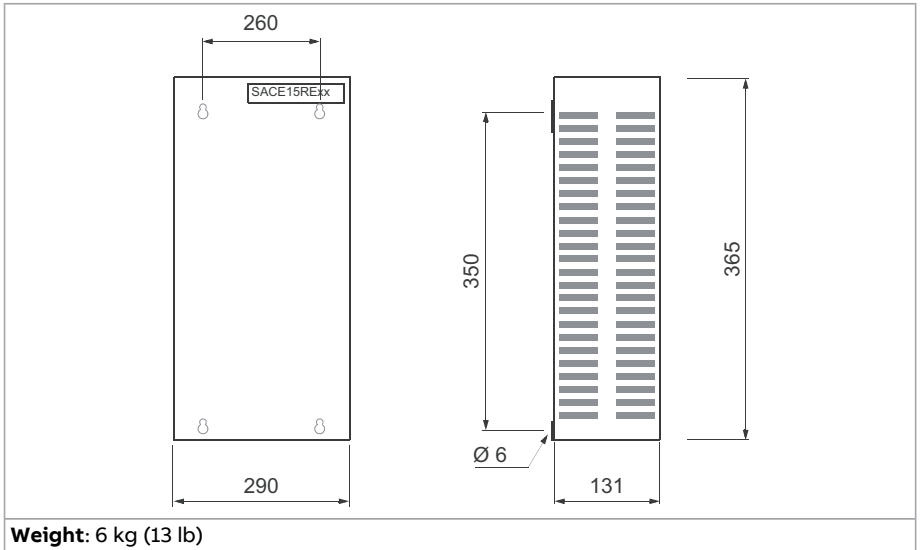

■ **SAFUR80F500 and SAFUR90F575**

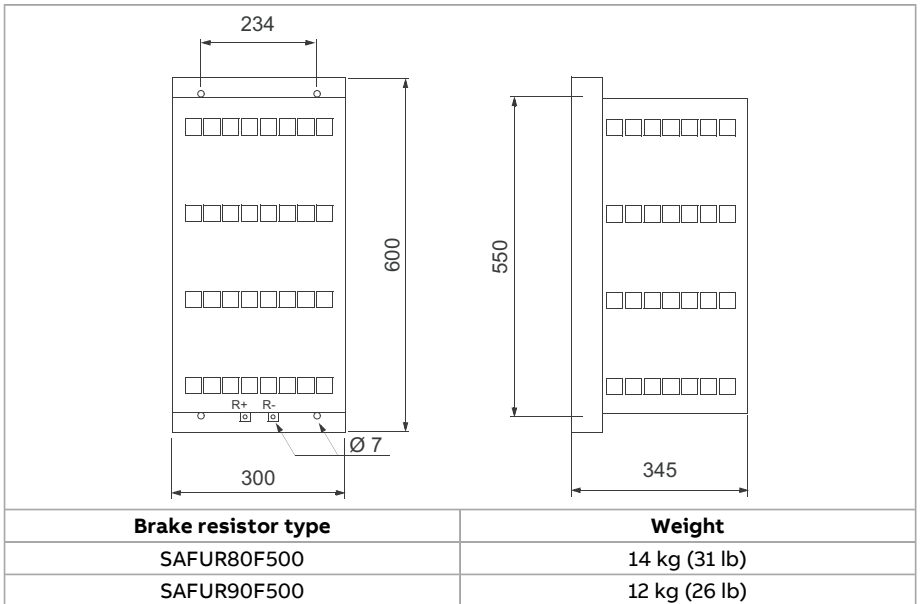

■ SAFUR125F500 and SAFUR200F500

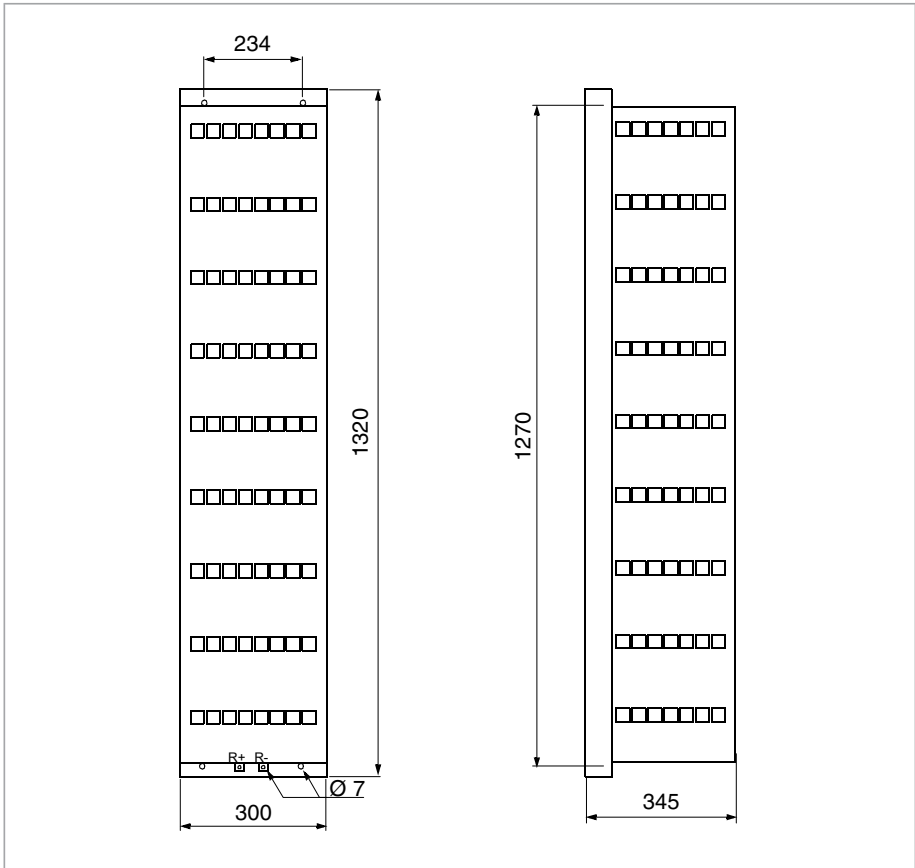

Brake resistor type	Weight
SAFUR125F500	25 kg (55 lb)
SAFUR200F500	30 kg (66 lb)



# 16

## The Safe torque off function

---

### Contents of this chapter

This chapter describes the Safe torque off (STO) function of the drive and gives instructions for its use.

### Description

---

**WARNING!**

In case of parallel-connected drives or dual-winding motors, the STO must be activated on each drive to remove the torque from the motor.

---

The Safe torque off function can be used, for example, as the final actuator device of safety circuits (such as an emergency stop circuit) that stop the drive in case of danger. Another typical application is a prevention of unexpected start-up function that enables short-time maintenance operations like cleaning or work on non-electrical parts of the machinery without switching off the power supply to the drive.

When activated, the Safe torque off function disables the control voltage for the power semiconductors of the drive output stage, thus preventing the drive from generating the torque required to rotate the motor. If the motor is running when Safe torque off is activated, it coasts to a stop.

The Safe torque off function has a redundant architecture, that is, both channels must be used in the safety function implementation. The safety data given in this manual is calculated for redundant use, and does not apply if both channels are not used.

---

The Safe torque off function complies with these standards:

Standard	Name
IEC 60204-1:2016 EN 60204-1:2018	Safety of machinery – Electrical equipment of machines – Part 1: General requirements
IEC 61000-6-7:2014	Electromagnetic compatibility (EMC) – Part 6-7: Generic standards – Immunity requirements for equipment intended to perform functions in a safety-related system (functional safety) in industrial locations
IEC 61326-3-1:2017	Electrical equipment for measurement, control and laboratory use – EMC requirements – Part 3-1: Immunity requirements for safety-related systems and for equipment intended to perform safety-related functions (functional safety) – General industrial applications
IEC 61508-1:2010	Functional safety of electrical/electronic/programmable electronic safety-related systems – Part 1: General requirements
IEC 61508-2:2010	Functional safety of electrical/electronic/programmable electronic safety-related systems – Part 2: Requirements for electrical/electronic/programmable electronic safety-related systems
IEC 61511-1:2017	Functional safety – Safety instrumented systems for the process industry sector
IEC 61800-5-2:2016 EN 61800-5-2:2007	Adjustable speed electrical power drive systems – Part 5-2: Safety requirements – Functional
IEC 62061:2021 EN 62061:2021	Safety of machinery – Functional safety of safety-related electrical, electronic and programmable electronic control systems
EN ISO 13849-1:2015	Safety of machinery – Safety-related parts of control systems – Part 1: General principles for design
EN ISO 13849-2:2012	Safety of machinery – Safety-related parts of control systems – Part 2: Validation

The function also corresponds to Prevention of unexpected start-up as specified by EN ISO 14118:2018 (ISO 14118:2017), and Uncontrolled stop (stop category 0) as specified in EN/IEC 60204-1.

■ **Compliance with the European Machinery Directive and the UK Supply of Machinery (Safety) Regulations**

The Declarations of conformity are shown at the end of this chapter.

## Wiring

For the electrical specifications of the STO connection, see the technical data of the control unit.

### ■ Activation switch

In the wiring diagrams, the activation switch has the designation [K]. This represents a component such as a manually operated switch, an emergency stop push button switch, or the contacts of a safety relay or safety PLC.

- In case a manually operated activation switch is used, the switch must be of a type that can be locked out to the open position.
- The contacts of the switch or relay must open/close within 200 ms of each other.
- An FSO safety functions module, an FSPS safety functions module or an FPTC thermistor protection module can also be used. For more information, see the module documentation.

### ■ Cable types and lengths

- ABB recommends double-shielded twisted-pair cable.
- Maximum cable lengths:
  - 300 m (1000 ft) between activation switch [K] and drive control unit
  - 60 m (200 ft) between multiple drives
  - 60 m (200 ft) between external power supply and first control unit

**Note:** A short-circuit in the wiring between the switch and an STO terminal causes a dangerous fault. Therefore, it is recommended to use a safety relay (including wiring diagnostics) or a wiring method (shield grounding, channel separation) which reduces or eliminates the risk caused by the short-circuit.

**Note:** The voltage at the STO input terminals of the control unit must be at least 17 V DC to be interpreted as “1”.

The pulse tolerance of the input channels is 1 ms.

### ■ Grounding of protective shields

- Ground the shield in the cabling between the activation switch and the control unit at the control unit only.
  - Ground the shield in the cabling between two control units at one control unit only.
-

■ Single drive (internal power supply)

Dual-channel connection

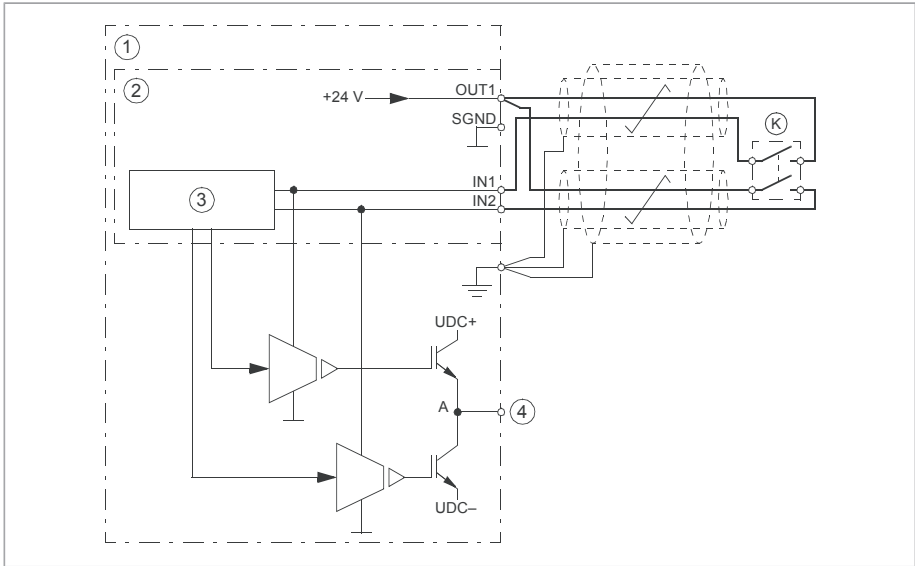

1	Drive
2	Control unit
3	Control logic
4	To motor
K	Activation switch

## Single-channel connection

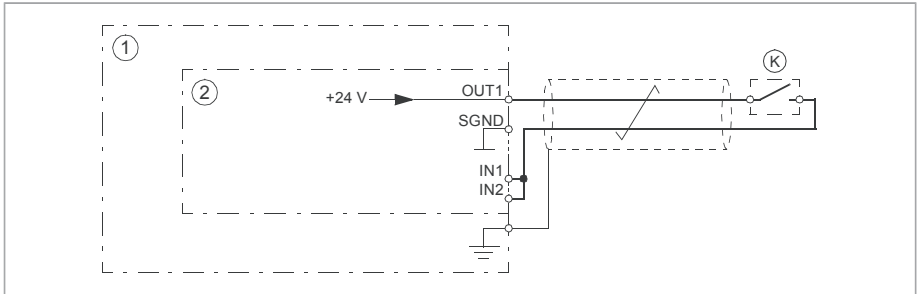
**Note:**

- Both STO inputs (IN1, IN2) must be connected to the activation switch. Otherwise, no SIL/PL classification is given.
- Pay special attention to avoiding any potential failure modes for the wiring. For example, use shielded cable. For measures for fault exclusion of wiring, see eg. EN ISO 13849-2:2012, table D.4.

1	Drive
2	Control unit
K	Activation switch <b>Note:</b> A single-channel activation switch can limit the SIL/PL capability of the safety function to a lower level than the SIL/PL capability of the STO function of the drive.

■ Multiple drives

Internal power supply

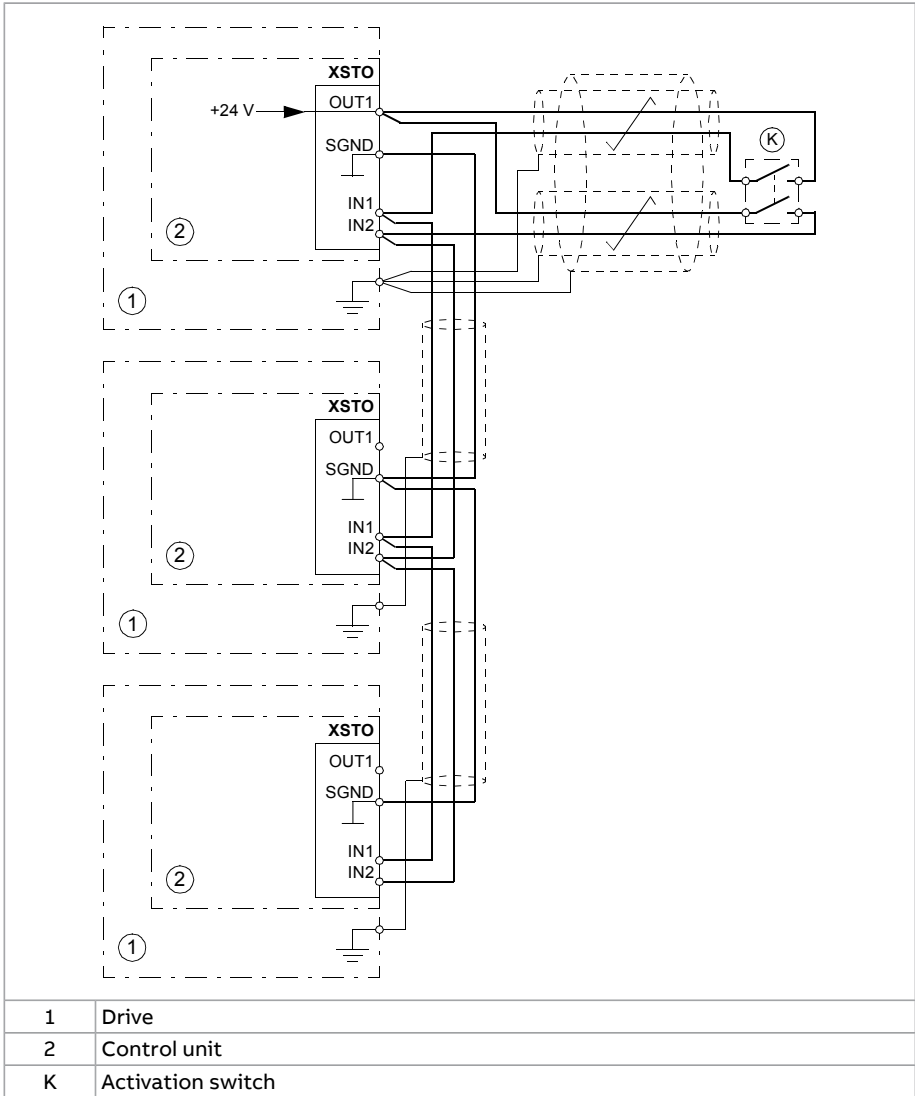

**External power supply**

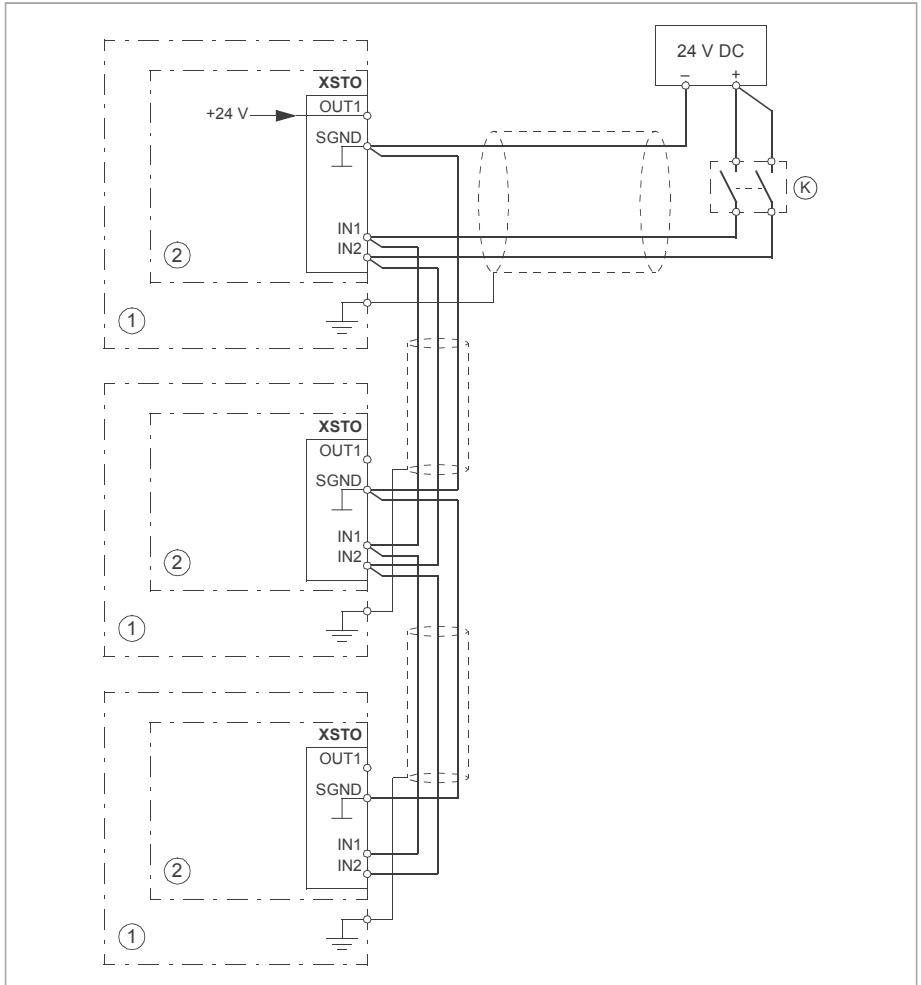

1	Drive
2	Control unit
K	Activation switch

## Operation principle

1. The Safe torque off activates (the activation switch is opened, or safety relay contacts open).
2. The STO inputs of the drive control unit de-energize.
3. The control unit cuts off the control voltage from the output IGBTs.
4. The control program generates an indication as defined by parameter 31.22 (see the firmware manual of the drive).

The parameter selects which indications are given when one or both STO signals are switched off or lost. The indications also depend on whether the drive is running or stopped when this occurs.

**Note:** This parameter does not affect the operation of the STO function itself. The STO function will operate regardless of the setting of this parameter: a running drive will stop upon removal of one or both STO signals, and will not start until both STO signals are restored and all faults reset.

**Note:** The loss of only one STO signal always generates a fault as it is interpreted as a malfunction of STO hardware or wiring.

5. The motor coasts to a stop (if running). The drive cannot restart while the activation switch or safety relay contacts are open. After the contacts close, a reset may be needed (depending on the setting of parameter 31.22). A new start command is required to start the drive.
-



## Start-up including validation test

To ensure the safe operation of a safety function, validation is required. The final assembler of the machine must validate the function by performing a validation test. The test must be performed

1. at initial start-up of the safety function
2. after any changes related to the safety function (circuit boards, wiring, components, settings, replacement of inverter module, etc.)
3. after any maintenance work related to the safety function
4. after a drive firmware update
5. at the proof test of the safety function.

### ■ Competence

The validation test of the safety function must be carried out by a competent person with adequate expertise and knowledge of the safety function as well as functional safety, as required by IEC 61508-1 clause 6. The test procedures and report must be documented and signed by this person.

### ■ Validation test reports

Signed validation test reports must be stored in the logbook of the machine. The report shall include documentation of start-up activities and test results, references to failure reports and resolution of failures. Any new validation tests performed due to changes or maintenance shall be logged into the logbook.

### ■ Validation test procedure

After wiring the Safe torque off function, validate its operation as follows.

**Note:** If the drive is equipped with safety option +Q972, +Q973 or +Q982, also do the procedure shown in the FSO module documentation.

If an FSPS-21 module is installed, refer to its documentation.

<b>Action</b>	<input checked="" type="checkbox"/>
 <b>WARNING!</b> Obey the safety instructions. If you ignore them, injury or death, or damage to the equipment can occur.	<input type="checkbox"/>
Make sure that the motor can be run and stopped freely during start-up.	<input type="checkbox"/>
Stop the drive (if running), switch the input power off and isolate the drive from the power line using a disconnecter.	<input type="checkbox"/>
Check the STO circuit connections against the wiring diagram.	<input type="checkbox"/>

### 302 The Safe torque off function

<b>Action</b>	<input checked="" type="checkbox"/>
Close the disconnecter and switch the power on.	<input type="checkbox"/>
<p>Test the operation of the STO function when the motor is stopped.</p> <ul style="list-style-type: none"> <li>• Give a stop command for the drive (if running) and wait until the motor shaft is at a standstill.</li> </ul> <p>Make sure that the drive operates as follows:</p> <ul style="list-style-type: none"> <li>• Open the STO circuit. The drive generates an indication if one is defined for the 'stopped' state in parameter 31.22 (see the firmware manual).</li> <li>• Give a start command to verify that the STO function blocks the drive's operation. The motor should not start.</li> <li>• Close the STO circuit.</li> <li>• Reset any active faults. Restart the drive and check that the motor runs normally.</li> </ul>	<input type="checkbox"/>
<p>Test the operation of the STO function when the motor is running.</p> <ul style="list-style-type: none"> <li>• Start the drive and make sure the motor is running.</li> <li>• Open the STO circuit. The motor should stop. The drive generates an indication if one is defined for the 'running' state in parameter 31.22 (see the firmware manual).</li> <li>• Reset any active faults and try to start the drive.</li> <li>• Make sure that the motor stays at a standstill and the drive operates as described above in testing the operation when the motor is stopped.</li> <li>• Close the STO circuit.</li> <li>• Reset any active faults. Restart the drive and check that the motor runs normally.</li> </ul>	<input type="checkbox"/>
<p>Test the operation of the failure detection of the drive. The motor can be stopped or running.</p> <ul style="list-style-type: none"> <li>• Open the 1st input channel of the STO circuit. If the motor was running, it should coast to a stop. The drive generates an FA81 fault indication (see the firmware manual).</li> <li>• Give a start command to verify that the STO function blocks the drive's operation. The motor should not start.</li> <li>• Close the STO circuit.</li> <li>• Reset any active faults. Restart the drive and check that the motor runs normally.</li> <li>• Open the 2nd input channel of the STO circuit. If the motor was running, it should coast to a stop. The drive generates an FA82 fault indication (see the firmware manual).</li> <li>• Give a start command to verify that the STO function blocks the drive's operation. The motor should not start.</li> <li>• Close the STO circuit.</li> <li>• Reset any active faults. Restart the drive and check that the motor runs normally.</li> </ul>	<input type="checkbox"/>
Document and sign the validation test report which verifies that the safety function is safe and accepted for operation.	<input type="checkbox"/>

## Use

1. Open the activation switch, or activate the safety functionality that is wired to the STO connection.
2. The STO inputs on the drive control unit de-energize, and the control unit cuts off the control voltage from the output IGBTs.
3. The control program generates an indication as defined by parameter 31.22 (see the firmware manual of the drive).
4. The motor coasts to a stop (if running). The drive will not restart while the activation switch or safety relay contacts are open.
5. Deactivate the STO by closing the activation switch, or resetting the safety functionality that is wired to the STO connection.
6. Reset any faults before restarting.



### WARNING!

The Safe torque off function does not disconnect the voltage of the main and auxiliary circuits from the drive. Therefore maintenance work on electrical parts of the drive or the motor can only be carried out after isolating the drive from the supply and all other voltage sources.

---



### WARNING!

The drive cannot detect or memorize any changes in the STO circuitry when the drive control unit is not powered. If both STO circuits are closed and a level-type start signal is active when the power is restored, it is possible that the drive starts without a fresh start command. Take this into account in the risk assessment of the system.

---



### WARNING!

Permanent magnet or synchronous reluctance [SynRM] motors only:

In case of a multiple IGBT power semiconductor failure, the drive can produce an alignment torque which maximally rotates the motor shaft by  $180/p$  degrees (with permanent magnet motors) or  $180/2p$  degrees (with synchronous reluctance [SynRM] motors) regardless of the activation of the Safe torque off function.  $p$  denotes the number of pole pairs.

---

### Notes:

- If a running drive is stopped by using the Safe torque off function, the drive will cut off the motor supply voltage and the motor will coast to a stop. If this causes danger or is not otherwise acceptable, stop the drive and machinery using the appropriate stop mode before activating the Safe torque off function.
-

## 304 The Safe torque off function

- The Safe torque off function overrides all other functions of the drive.
  - The Safe torque off function is ineffective against deliberate sabotage or misuse.
  - The Safe torque off function has been designed to reduce the recognized hazardous conditions. In spite of this, it is not always possible to eliminate all potential hazards. The assembler of the machine must inform the final user about the residual risks.
-

## Maintenance

After the operation of the circuit is validated at start-up, the STO function shall be maintained by periodic proof testing. In high demand mode of operation, the maximum proof test interval is 20 years. In low demand mode of operation, the maximum proof test interval is 5 years; see section [Safety data \(page 307\)](#). It is assumed that all dangerous failures of the STO circuit are detected by the proof test. To perform the proof test, do the [Validation test procedure \(page 301\)](#).

**Note:** See also the Recommendation of Use CNB/M/11.050 (published by the European co-ordination of Notified Bodies) concerning dual-channel safety-related systems with electromechanical outputs:

- When the safety integrity requirement for the safety function is SIL 3 or PL e (cat. 3 or 4), the proof test for the function must be performed at least every month.
- When the safety integrity requirement for the safety function is SIL 2 (HFT = 1) or PL d (cat. 3), the proof test for the function must be performed at least every 12 months.

The STO function of the drive does not contain any electromechanical components.

In addition to proof testing, it is a good practice to check the operation of the function when other maintenance procedures are carried out on the machinery.

Include the Safe torque off operation test described above in the routine maintenance program of the machinery that the drive runs.

If any wiring or component change is needed after start-up, or the parameters are restored, do the test given in section [Validation test procedure \(page 301\)](#).

Use only spare parts approved by ABB.

Record all maintenance and proof test activities in the machine logbook.

### ■ Competence

The maintenance and proof test activities of the safety function must be carried out by a competent person with adequate expertise and knowledge of the safety function as well as functional safety, as required by IEC 61508-1 clause 6.

---

## **Fault tracing**

The indications given during the normal operation of the Safe torque off function are selected by drive control program parameter 31.22.

The diagnostics of the Safe torque off function cross-compare the status of the two STO channels. In case the channels are not in the same state, a fault reaction function is performed and the drive trips on an FA81 or FA82 fault. An attempt to use the STO in a non-redundant manner, for example activating only one channel, will trigger the same reaction.

See the firmware manual of the drive control program for the indications generated by the drive, and for details on directing fault and warning indications to an output on the control unit for external diagnostics.

Any failures of the Safe torque off function must be reported to ABB.

---

## Safety data

The safety data for the Safe torque off function is given below.

**Note:** The safety data is calculated for redundant use, and applies only if both STO channels are used.

Frame size	SIL	PL	SFF (%)	PFH ( $\tau_1 = 20$ a) (1/h)	PFD <sub>avg</sub> ( $\tau_1 = 2$ a)	PFD <sub>avg</sub> ( $\tau_1 = 5$ a)	MTTF <sub>D</sub> (a)	DC (%)	Cat.	SC	HFT	CCF	T <sub>M</sub> (a)
$U_n = 230$ V													
R1	3	e	>99	2.84E-09	2.37E-05	5.91E-05	10530	≥90	3	3	1	80	20
R2	3	e	>99	2.84E-09	2.37E-05	5.91E-05	10529	≥90	3	3	1	80	20
R3	3	e	>99	2.84E-09	2.37E-05	5.91E-05	10489	≥90	3	3	1	80	20
R4	3	e	>99	2.89E-09	2.41E-05	6.02E-05	10442	≥90	3	3	1	80	20
R5	3	e	>99	2.89E-09	2.41E-05	6.02E-05	10240	≥90	3	3	1	80	20
R6 R7 R8	3	e	>99	2.89E-09	2.41E-05	6.02E-05	10340	≥90	3	3	1	80	20
$U_n = 400$ V, $U_n = 500$ V													
R1	3	e	>99	2.84E-09	2.37E-05	5.91E-05	10530	≥90	3	3	1	80	20
R2	3	e	>99	2.84E-09	2.37E-05	5.91E-05	10529	≥90	3	3	1	80	20
R3	3	e	>99	2.84E-09	2.37E-05	5.91E-05	10489	≥90	3	3	1	80	20
R4	3	e	>99	2.89E-09	2.41E-05	6.02E-05	10442	≥90	3	3	1	80	20
R5	3	e	>99	2.89E-09	2.41E-05	6.02E-05	10240	≥90	3	3	1	80	20
R6 R7	3	e	>99	2.89E-09	2.41E-05	6.02E-05	10340	≥90	3	3	1	80	20
R8 R9	3	e	99.1	3.21E-09	2.67E-05	6.67E-05	9630	≥90	3	3	1	80	20
$U_n = 690$ V													
R3	3	e	98.5	3.24E-09	2.68E-05	6.69E-05	6221	≥90	3	3	1	80	20
R5	3	e	98.5	3.23E-09	2.67E-05	6.68E-05	5879	≥90	3	3	1	80	20
R6 R7 R8 R9	3	e	99.1	3.21E-09	2.66E-05	6.66E-05	10008	≥90	3	3	1	80	20
3AXD1000006217 N, 3AXD10000083197 H													

## 308 The Safe torque off function

- The following temperature profile is used in safety value calculations:
  - 670 on/off cycles per year with  $\Delta T = 71.66\text{ }^{\circ}\text{C}$
  - 1340 on/off cycles per year with  $\Delta T = 61.66\text{ }^{\circ}\text{C}$
  - 30 on/off cycles per year with  $\Delta T = 10.0\text{ }^{\circ}\text{C}$
  - 32 °C board temperature at 2.0% of time
  - 60 °C board temperature at 1.5% of time
  - 85 °C board temperature at 2.3% of time.
- The STO is a type A safety component as defined in IEC 61508-2.
- Relevant failure modes:
  - The STO trips spuriously (safe failure)
  - The STO does not activate when requested
  - A fault exclusion on the failure mode “short circuit on printed circuit board” has been made (EN 13849-2, table D.5). The analysis is based on an assumption that one failure occurs at one time. No accumulated failures have been analyzed.
- STO response times:
  - STO reaction time (shortest detectable break): 1 ms
  - STO response time: 2 ms (typical), 5 ms (maximum)
  - Fault detection time: Channels in different states for longer than 200 ms
  - Fault reaction time: Fault detection time + 10 ms.
- Indication delays:
  - STO fault indication (parameter 31.22) delay: < 500 ms
  - STO warning indication (parameter 31.22) delay: < 1000 ms.

### ■ Terms and abbreviations

Term or abbreviation	Reference	Description
Cat.	EN ISO 13849-1	Classification of the safety-related parts of a control system in respect of their resistance to faults and their subsequent behavior in the fault condition, and which is achieved by the structural arrangement of the parts, fault detection and/or by their reliability. The categories are: B, 1, 2, 3 and 4.
CCF	EN ISO 13849-1	Common cause failure (%)
DC	EN ISO 13849-1	Diagnostic coverage
HFT	IEC 61508	Hardware fault tolerance
MTTF <sub>D</sub>	EN ISO 13849-1	Mean time to dangerous failure: (Total number of life units) / (Number of dangerous, undetected failures) during a particular measurement interval under stated conditions



Term or abbreviation	Reference	Description
PFD <sub>avg</sub>	IEC 61508	Average probability of dangerous failure on demand, that is, mean unavailability of a safety-related system to perform the specified safety function when a demand occurs
PFH	IEC 61508	Average frequency of dangerous failures per hour, that is, average frequency of a dangerous failure of a safety related system to perform the specified safety function over a given period of time
PL	EN ISO 13849-1	Performance level. Levels a...e correspond to SIL
Proof test	IEC 61508, IEC 62061	Periodic test performed to detect failures in a safety-related system so that, if necessary, a repair can restore the system to an "as new" condition or as close as practical to this condition
SC	IEC 61508	Systematic capability
SFF	IEC 61508	Safe failure fraction (%)
SIL	IEC 61508	Safety integrity level (1...3)
STO	IEC/EN 61800-5-2	Safe torque off
$T_1$	IEC 61508-6	Proof test interval. $T_1$ is a parameter used to define the probabilistic failure rate (PFH or PFD) for the safety function or subsystem. Performing a proof test at a maximum interval of $T_1$ is required to keep the SIL capability valid. The same interval must be followed to keep the PL capability (EN ISO 13849) valid. See also section Maintenance.
$T_M$	EN ISO 13849-1	Mission time: the period of time covering the intended use of the safety function/device. After the mission time elapses, the safety device must be replaced. Note that any $T_M$ values given cannot be regarded as a guarantee or warranty.

### ■ TÜV certificate

The TÜV certificate is available on the Internet at [www.abb.com/drives/documents](http://www.abb.com/drives/documents).

## ■ Declarations of conformity



### EU Declaration of Conformity

Machinery Directive 2006/42/EC

We

Manufacturer: ABB Oy  
Address: Hiomotie 13, 00380 Helsinki, Finland.  
Phone: +358 10 22 11

declare under our sole responsibility that the following product:

**Frequency converter(s)**

ACS880-01/-11/-31  
ACS880-04/-04F/-M04/-14/-34

with regard to the safety function(s)

- Safe Torque Off
- Safe stop 1, Safe stop emergency, Safely-limited speed, Safe maximum speed, Safe brake control, Prevention of unexpected start-up (with FSO-12 option module, +Q973, encoderless)
- Safe stop 1, Safe stop emergency, Safely-limited speed, Safe maximum speed, Safe brake control, Safe speed monitor, Safe direction, Prevention of unexpected start-up (with FSO-21 and FSE-31 option modules, +Q972 and +L521, encoder supported)
- Safe motor temperature (with FPTC-01 thermistor protection module, +L536)
- Safe stop 1 (SSL-t, with FSPS-21 PROFIsafe module, +Q986)

is/are in conformity with all the relevant safety component requirements of EU Machinery Directive 2006/42/EC, when the listed safety function is used for safety component functionality.

The following harmonized standards have been applied:

EN 61800-5-2:2007	Adjustable speed electrical power drive systems – Part 5-2: Safety requirements - Functional
EN 62061:2005 + AC:2010 + A1:2013 + A2:2015	Safety of machinery – Functional safety of safety-related electrical, electronic and programmable electronic control systems
EN ISO 13849-1:2015	Safety of machinery – Safety-related parts of control systems. Part 1: General requirements
EN ISO 13849-2:2012	Safety of machinery – Safety-related parts of the control systems. Part 2: Validation
EN 60204-1:2018	Safety of machinery – Electrical equipment of machines – Part 1: General requirements

The following other standards have been applied:

IEC 61508:2010, parts 1-2	Functional safety of electrical / electronic / programmable electronic safety-related systems
IEC 61800-5-2:2016	Adjustable speed electrical power drive systems – Part 5-2: Safety requirements - Functional

The product(s) referred in this Declaration of conformity fulfil(s) the relevant provisions of other European Union Directives which are notified in Single EU Declaration of conformity 3AXD10000497831.

Person authorized to compile the technical file:  
Name and address: Jussi Vesti, Hiomotie 13, 00380 Helsinki, Finland.

Helsinki, 20.10.2020  
Signed for and on behalf of:

  
Tuomo Tarula  
Vice president, ABB

  
Vesa Tuomainen  
Product Engineering manager, ABB

Document number 3AXD1000099646



## Declaration of Conformity

Supply of Machinery (Safety) Regulations 2008

We

Manufacturer: ABB Oy  
 Address: Hiomotie 13, 00380 Helsinki, Finland.  
 Phone: +358 10 22 11

declare under our sole responsibility that the following products:

### Frequency converters

ACS880-01/-11/-31  
 ACS880-04/-04F/-M04/-14/-34

with regard to the safety functions

- Safe Torque Off
- Safe stop 1, Safe stop emergency, Safely-limited speed, Safe maximum speed, Safe brake control, Prevention of unexpected start-up (with FSO-12 option module, +Q973, encoderless)
- Safe stop 1, Safe stop emergency, Safely-limited speed, Safe maximum speed, Safe brake control, Safe speed monitor, Safe direction, Prevention of unexpected start-up (with FSO-21 and FSE-31 option modules, +Q972 and +L521, encoder supported)
- Safe motor temperature (with FPTC-01 thermistor protection module, +L536)
- Safe stop 1 (SSI-t, with FSP5-21 PROFIsafe module, +Q986)

are in conformity with all the relevant safety component requirements of the Supply of Machinery (Safety) Regulations 2008, when the listed safety functions are used for safety component functionality.

The following harmonized standards have been applied:

EN 61800-5-2:2007	Adjustable speed electrical power drive systems – Part 5-2: Safety requirements - Functional
EN 62061:2005 + AC:2010 + A1:2013 + A2:2015	Safety of machinery – Functional safety of safety-related electrical, electronic and programmable electronic control systems
EN ISO 13849-1:2015	Safety of machinery – Safety-related parts of control systems. Part 1: General requirements
EN ISO 13849-2:2012	Safety of machinery – Safety-related parts of the control systems. Part 2: Validation
EN 60204-1:2018	Safety of machinery – Electrical equipment of machines – Part 1: General requirements
The following other standards have been applied: IEC 61508:2010, parts 1-2	Functional safety of electrical / electronic / programmable electronic safety-related systems
IEC 61800-5-2:2016	Adjustable speed electrical power drive systems – Part 5-2: Safety requirements - Functional

The product(s) referred in this declaration of conformity fulfil(s) the relevant provisions of other UK statutory requirements, which are notified in a single declaration of conformity 3AXD10001326405.

Authorized to compile the technical file: ABB Limited, Daresbury Park, Cheshire, United Kingdom, WA4 4BT.

Helsinki, May 7, 2021

Signed for and on behalf of:

Tuomo Tarula  
 Local Division Manager, ABB Oy

Aaron D. Wade  
 Product Unit Manager, ABB Oy

Document number 3AXD10001329538





# Filters

---

## Contents of this chapter

This chapter describes how to select external filters for the drive.

### When is a common mode filter or $du/dt$ filter needed?

See section [Examining the compatibility of the motor and drive \(page 63\)](#). A common mode filter kits are available from ABB. The kits includes three wound cores. For installation instructions of the cores, see the instruction included in the core package.

### Common mode filters

Common mode filter kits are available from ABB. The kits includes three wound cores.

Name	Code
Common mode filter kit for ACS880-01 frame R6 (option +E208) installation instructions	<a href="#">3AXD50000015178</a>
Common mode filter kit for ACS880-01 frame R7, and for ACS880-11, ACS880-31 frame R8 (option +E208) installation instructions	<a href="#">3AXD50000015179</a>
Common mode filter kit for ACS880-01 drives (frame R9, option +E208) installation instructions	<a href="#">3AXD50000015201</a>

---

## du/dt filters

### ■ du/dt filter types

ACS880-01-...	du/dt filter type	ACS880-01-...	du/dt filter type	ACS880-01-...	du/dt filter type
$U_N = 400\text{ V}$		$U_N = 500\text{ V}$		$U_N = 690\text{ V}$	
02A4-3	NOCH0016-6X	02A1-5	NOCH0016-6X	07A4-7	NOCH0016-6X
03A3-3	NOCH0016-6X	03A0-5	NOCH0016-6X	09A9-7	NOCH0016-6X
04A0-3	NOCH0016-6X	03A4-5	NOCH0016-6X	14A3-7	NOCH0016-6X
05A6-3	NOCH0016-6X	04A8-5	NOCH0016-6X	019A-7	NOCH0030-6X
07A2-3	NOCH0016-6X	05A2-5	NOCH0016-6X	023A-7	NOCH0030-6X
09A4-3	NOCH0016-6X	07A6-5	NOCH0016-6X	027A-7	NOCH0030-6X
12A6-3	NOCH0016-6X	11A0-5	NOCH0016-6X	07A3-7	NOCH0016-6X
017A-3	NOCH0030-6X	014A-5	NOCH0030-6X	09A8-7	NOCH0016-6X
025A-3	NOCH0030-6X	021A-5	NOCH0030-6X	14A2-7	NOCH0016-6X
032A-3	NOCH0070-6X	027A-5	NOCH0070-6X	018A-7	NOCH0030-6X
038A-3	NOCH0070-6X	034A-5	NOCH0070-6X	022A-7	NOCH0030-6X
045A-3	NOCH0070-6X	040A-5	NOCH0070-6X	026A-7	NOCH0030-6X
061A-3	NOCH0070-6X	052A-5	NOCH0070-6X	035A-7	NOCH0070-6X
072A-3	NOCH0120-6X	065A-5	NOCH0120-6X	042A-7	NOCH0070-6X
087A-3	NOCH0120-6X	077A-5	NOCH0120-6X	049A-7	NOCH0070-6X
105A-3	NOCH0120-6X	096A-5	NOCH0120-6X	061A-7	NOCH0120-6X
145A-3	FOCH0260-7X	124A-5	FOCH0260-7X	084A-7	NOCH0120-6X
169A-3	FOCH0260-7X	156A-5	FOCH0260-7X	098A-7	NOCH0120-6X
206A-3	FOCH0260-7X	180A-5	FOCH0260-7X	119A-7	FOCH0260-7X
246A-3	FOCH0260-7X	240A-5	FOCH0260-7X	142A-7	FOCH0260-7X
293A-3	FOCH0260-7X	260A-5	FOCH0260-7X	174A-7	FOCH0260-7X
363A-3	FOCH0320-5X	302A-5	FOCH0320-5X	210A-7	FOCH0260-7X
430A-3	FOCH0320-5X	361A-5	FOCH0320-5X	271A-7	FOCH0260-7X
		414A-5	FOCH0320-5X		

### ■ Description, installation and technical data of the du/dt filters

See

- [FOCH du/dt filters hardware manual \(3AFE68577519 \[English\]\)](#)
- [AOCH and NOCH du/dt filters hardware manual \(3AFE58933368 \[English\]\)](#).

## Sine filters

### ■ Selecting a sine filter for a drive

Check housing of sine filters from the manufacturer's internet pages. Go to <https://en.tdk.eu>

ACS880-01-...	Sine filter type	$I_{cont. max}$	$P_{cont. max}$	Heat dissipation			Noise
				Drive	Filter	Total	
		A	kW	W	W	W	dB (A)
$U_N = 400 V$							
02A4-3	B84143V0004R229*	2.3	1.7	30	60	90	72
03A3-3	B84143V0004R229*	3.1	2.3	40	60	100	72
04A0-3	B84143V0004R229*	3.8	2.9	52	60	112	72
05A6-3	B84143V0006R229*	5.3	4.0	73	100	173	72
07A2-3	B84143V0011R229*	7.2	5.4	94	90	184	72
09A4-3	B84143V0011R229*	9.2	6.9	122	90	212	72
12A6-3	B84143V0016R229*	12.1	9.1	172	80	252	72
017A-3	B84143V0025R229*	16	12.1	232	140	372	75
025A-3	B84143V0025R229*	24	17.7	337	140	477	75
032A-3	B84143V0033R229*	31	23.4	457	160	617	75
038A-3	B84143V0050R229*	37	27.5	562	220	782	78
045A-3	B84143V0050R229*	43	32.4	667	220	887	78
061A-3	B84143V0066R229*	58	43.7	907	250	1157	78
072A-3	B84143V0075R229*	64	48.2	1117	310	1427	79
087A-3	B84143V0095R229*	77	58.0	1120	400	1520	79
105A-3	B84143V0130S230**	91	68.6	1295	600	1895	80
145A-3	B84143V0162S229**	126	94.6	1440	550	1990	80
169A-3	B84143V0162S229**	153	115.0	1940	550	2490	80
206A-3	B84143V0230S229**	187	140.6	2310	900	3210	80
246A-3	B84143V0230S229**	209	157.6	3300	900	4200	80
293A-3	B84143V0390S229**	249	187.8	3900	1570	5470	80
363A-3	B84143V0390S229**	297	223.6	4800	1570	6370	80
430A-3	B84143V0390S229**	352	265.2	6000	1570	7570	80
$U_N = 500 V$							
02A1-5	B84143V0004R229*	1.9	1.4	30	60	90	72
03A0-5	B84143V0004R229*	2.8	2.1	40	60	100	72
03A4-5	B84143V0004R229*	3.1	2.3	52	60	112	72
04A8-5	B84143V0006R229*	4.4	3.3	73	100	173	72
05A2-5	B84143V0006R229*	4.8	3.6	94	100	194	72
07A6-5	B84143V0011R229*	7.0	5.3	122	90	212	72
11A0-5	B84143V0011R229*	10.2	7.7	172	90	262	72
* minimum switching frequency 4.5 kHz							
** minimum switching frequency 3.6 kHz							

316 Filters

ACS880-01-...	Sine filter type	$I_{cont. max}$	$P_{cont. max}$	Heat dissipation			Noise
				Drive	Filter	Total	
		A	kW	W	W	W	dB (A)
014A-5	B84143V0016R229*	13	9.8	232	80	312	70
021A-5	B84143V0025R229*	20	14.7	337	140	477	75
027A-5	B84143V0033R229*	25	18.8	457	160	617	75
034A-5	B84143V0050R229*	32	23.7	562	220	782	78
040A-5	B84143V0050R229*	35	26.0	667	220	887	78
052A-5	B84143V0066R229*	44	33.2	907	250	1157	78
065A-5	B84143V0066R229*	52	39.2	1117	250	1367	78
077A-5	B84143V0075R229*	61	46.0	1120	310	1430	78
096A-5	B84143V0130R230**	80	60.6	1295	630	1925	80
124A-5	B84143V0130S230**	104	78.7	1440	630	2070	80
156A-5	B84143V0162S229**	140	105.8	1940	550	2490	80
180A-5	B84143V0162S229**	161	121.3	2310	550	2860	80
240A-5	B84143V0230S229**	205	154.3	3300	900	4200	80
260A-5	B84143V0230S229**	221	166.7	3900	900	4800	80
361A-5	B84143V0390S229**	289	217.9	4800	1570	6370	80
414A-5	B84143V0390S229**	332	250.1	6000	1570	7570	80
$U_N = 690 V$							
07A4-7	B84143V0010R230*	7.3	5.5	114	90	204	72
09A9-7	B84143V0010R230*	9.3	7.0	143	90	233	72
14A3-7	B84143V0018R230*	13.5	10.2	207	130	337	72
019A-7	B84143V0018R230*	17.1	12.9	274	130	404	72
023A-7	B84143V0026R230*	21	15.7	329	160	489	72
027A-7	B84143V0026R230*	25	18.6	405	160	565	72
07A3-7	B84143V0010R230*	7.3	5.5	217	90	307	72
09A8-7	B84143V0010R230*	9.3	7.0	284	90	374	72
14A2-7	B84143V0018R230*	13.5	10.2	399	130	529	72
018A-7	B84143V0018R230*	17.1	12.9	490	130	620	72
022A-7	B84143V0026R230*	21	15.7	578	160	738	72
026A-7	B84143V0026R230*	25	18.6	660	160	820	72
035A-7	B84143V0040R230*	33	25.1	864	250	1114	75
042A-7	B84143V0040R230*	40	30.1	998	250	1248	75
049A-7	B84143V0056R230**	48	36.2	1120	290	1410	78
061A-7	B84143V0056R230**	56	42.5	1295	290	1585	78
084A-7	B84143V0092R230**	78	58.6	1440	610	2050	79
098A-7	B84143V0092R230**	92	69.3	1940	610	2550	79
119A-7	B84143V0130S230**	112	84.2	2310	630	2940	80
142A-7	B84143V0130S230**	112	84.7	3300	630	3930	80
* minimum switching frequency 4.5 kHz							
** minimum switching frequency 3.6 kHz							



ACS880-01-...	Sine filter type	$I_{\text{cont. max}}$	$P_{\text{cont. max}}$	Heat dissipation			Noise
				Drive	Filter	Total	
		A	kW	W	W	W	dB (A)
174A-7	B84143V0207S230**	138	103.7	3900	930	4830	80
210A-7	B84143V0207S230**	161	121.3	4200	930	5130	80
271A-7	B84143V0207S230**	208	156.4	4800	930	5730	80
3AXD00000588487							
* minimum switching frequency 4.5 kHz							
** minimum switching frequency 3.6 kHz							

## ■ Definitions

$P_{\text{cont. max}}$	Maximum continuous output power of the drive
$I_{\text{cont. max}}$	Maximum continuous output current of the drive
Noise	Noise level of the sine filters

## Derating

See section [Deratings for special settings in the drive control program](#) (page 198).

## Description, installation and technical data

See [Sine filters hardware manual \(3AXD50000016814 \[English\]\)](#).



---

## Further information

### Product and service inquiries

Address any inquiries about the product to your local ABB representative, quoting the type designation and serial number of the unit in question. A listing of ABB sales, support and service contacts can be found by navigating to [www.abb.com/searchchannels](http://www.abb.com/searchchannels).

### Product training

For information on ABB product training, navigate to [new.abb.com/service/training](http://new.abb.com/service/training).

### Providing feedback on ABB manuals

Your comments on our manuals are welcome. Navigate to [new.abb.com/drives/manuals-feedback-form](http://new.abb.com/drives/manuals-feedback-form).

### Document library on the Internet

You can find manuals and other product documents in PDF format on the Internet at [www.abb.com/drives/documents](http://www.abb.com/drives/documents).



[www.abb.com/drives](http://www.abb.com/drives)

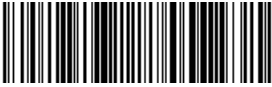

3AUA0000078093S